

20453C

# 7462SECR

PARISOT INDUSTRIE 70800 SAINT LOUP SUR SEMOUSE -FRANCE-

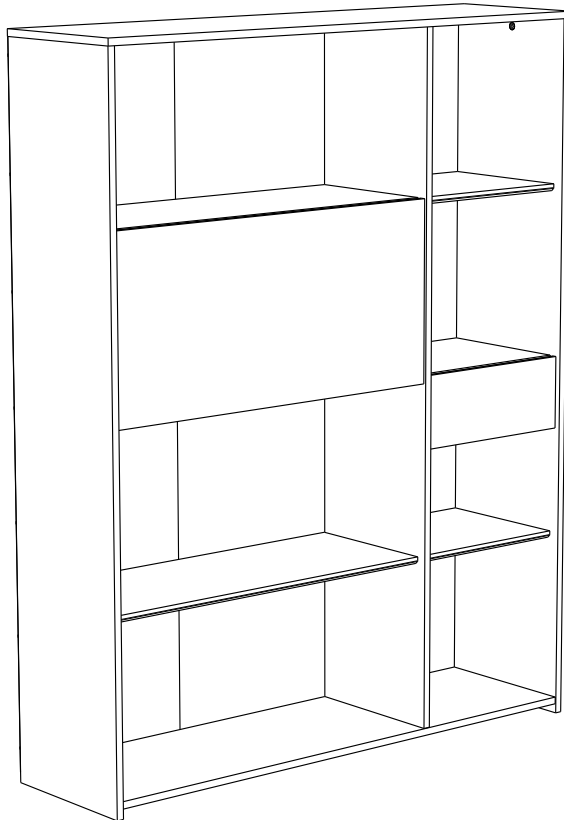

PARISOT INDUSTRIE

Gamme : PULL-UP

## FR Remerciements :

Nous vous remercions d'avoir choisi un meuble créé et fabriqué par le Groupe Pariset et espérons qu'il vous donnera entière satisfaction.

## EN Thanks:

Thank you for choosing furniture designed and manufactured by the Pariset Group. We hope you are totally satisfied with your purchase.

## DE Danksagung:

Wir danken Ihnen für den Kauf eines Frankreich von der Pariset-Gruppe entworfenen und hergestellten Möbelstücks und hoffen, dass Sie es zu Ihrer vollkommenen Zufriedenheit finden werden.

## HU Köszönet:

Köszönjük, hogy a Pariset Groupe által létrehozott és gyártott bútort választott, reméljük, hogy elégedett lesz a termékkel.

## PT Agradecimentos:

Obrigado por ter escolhido um móvel concebido e fabricado pelo Grupo Pariset, esperando que seja do seu inteiro agrado.

## IT Ringraziamenti:

Grazie per avere scelto un mobile progettato e fabbricato dal Gruppo Pariset. Speriamo soddisfatti appieno le vostre esigenze.

## NL Bedankje:

Wij bedanken u voor de aankoop van een door de Groep Pariset ontworpen en vervaardigd meubel en hopen dat u er veel plezier aan zult beleven.

## CZ Poděkování:

Děkujeme, že jste si vybrali nábytek navržený a vyrobený společností Pariset Group. Doufáme, že budete svým nákupem naprosto spokojeni.

## ES Agradecimientos:

Les damos las gracias por haber elegido un mueble diseñado y fabricado por el Grupo Pariset y esperamos que sea de su total agrado.

## PL Podziękowania:

Dziękujemy za wybór mebli stworzonych i wyprodukowanych przez Grupę Pariset. Mamy nadzieję, że będziecie Państwo w pełni zadowoleni z zakupu.

## RO Mulțumiri:

Vă mulțumim că ați ales un articol de mobilier conceput și fabricat de Grupul Pariset și sperăm că veți fi pe deplin satisfăcuți de acesta.

## RU Благодарность:

Мы благодарим вас за то, что вы выбрали мебель, созданную и произведенную Групп Паризо, и надеемся,

что вы будете полностью удовлетворены нашей продукцией.

## SK Pod'akovanie:

Ďakujeme, že ste si vybrali nábytok navrhnutý a vyrobený spoločnosťou Pariset Group. Dúfame, že budete svojim nákupom absolútne spokojní.

## SL Hvala:

Hvala, ker ste izbrali pohištvo, ki je dizajnirano in proizvedeno s strani Pariset Group. Upamo, da ste maksimalno zadovoljni z vašim nakupom.

## TR Teşekkür ederiz:

Pariset Group tarafından tasarlanan ve üretilen bu mobilyayı seçtiğiniz için teşekkür ederiz. Ürünümüzden memnun kalmanızı ümit ederiz.

## ZH 感谢 :

感谢您选择帕里索集团设计制造的家具。我们希望您对此次购买十分满意、

## AR : شكر

نشكركم لاختياركم هذه القطعة من الأثاث من تصميم وتصنيع مجموعة باريزو Pariset ونتمنى أن تتال رضاءكم.

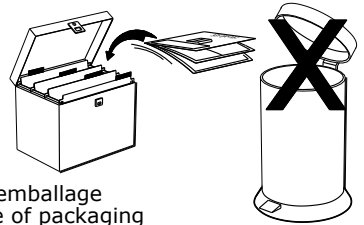

Faites un geste pour l'environnement en triant vos déchets d'emballage  
Make a gesture for the environment by sorting out your waste of packaging  
Machen Sie eine Bewegung für die Umwelt, ihre Verpackungsabfälle sortierend  
Haga un gesto para el medio ambiente escogiendo sus residuos de embalaje  
Pensate all'ambiente riciclando i vostri rifiuti di imballaggio  
Naredite uslugo okolju in lo ujte odpadke

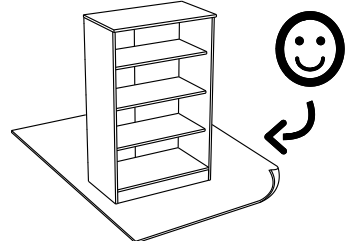
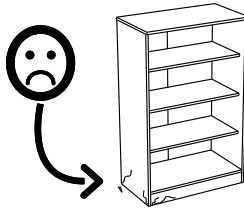
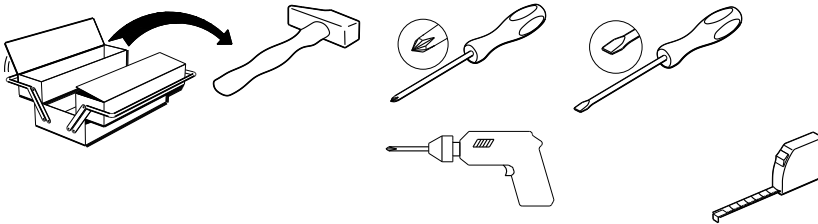

151.5cm  
59 3/4"  
120cm  
47 1/4"  
33cm  
13"

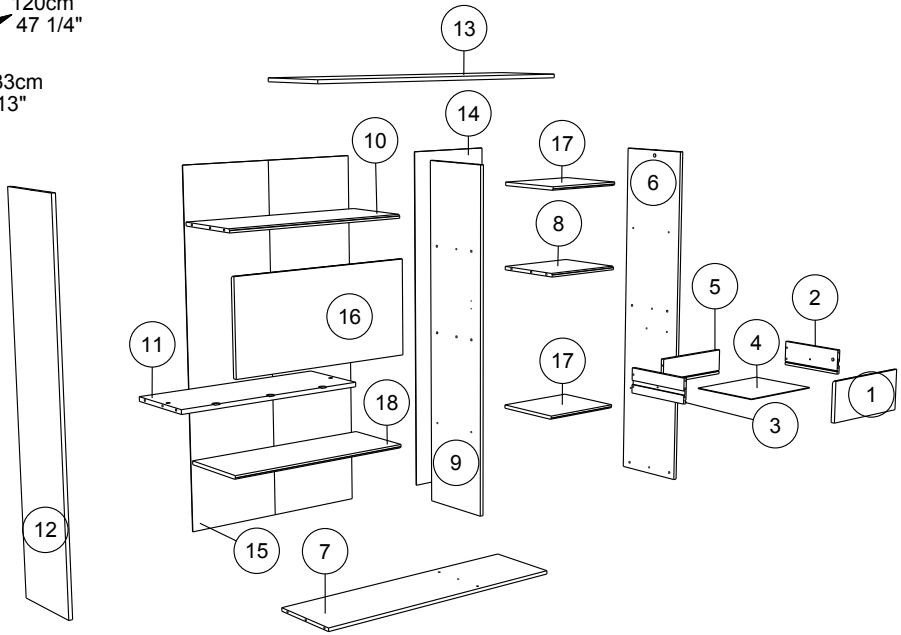

			mm			inch		
①	x	1	359	155	15	14 1/8	6 1/8	9/16
①⑦	x	2	363	302	15	14 5/16	11 7/8	9/16
⑧	x	1	364	302	15	14 5/16	11 7/8	9/16
①⑥	x	1	780	383	18	30 11/16	15 1/16	11/16
①⑧	x	1	784	302	15	30 7/8	11 7/8	9/16
①⑩	x	1	785	302	15	30 7/8	11 7/8	9/16
①①	x	1	785	302	18	30 7/8	11 7/8	11/16
⑦	x	1	1164	325	15	45 13/16	12 13/16	9/16
①③	x	1	1196	329	15	47 1/16	12 15/16	9/16
⑨	x	1	1465	323	15	57 11/16	12 11/16	9/16
⑥	x	1	1500	327	15	59 1/16	12 7/8	9/16
①②	x	1	1500	327	15	59 1/16	12 7/8	9/16
②	x	1	275	100	13	10 13/16	3 15/16	1/2
③	x	1	275	100	13	10 13/16	3 15/16	1/2
⑤	x	1	331	100	13	13 1/16	3 15/16	1/2
④	x	1	343	274	3	13 1/2	10 13/16	1/8
①④	x	1	1493	385	3	58 3/4	15 3/16	1/8
①⑤	x	1	1493	806	3	58 3/4	31 3/4	1/8

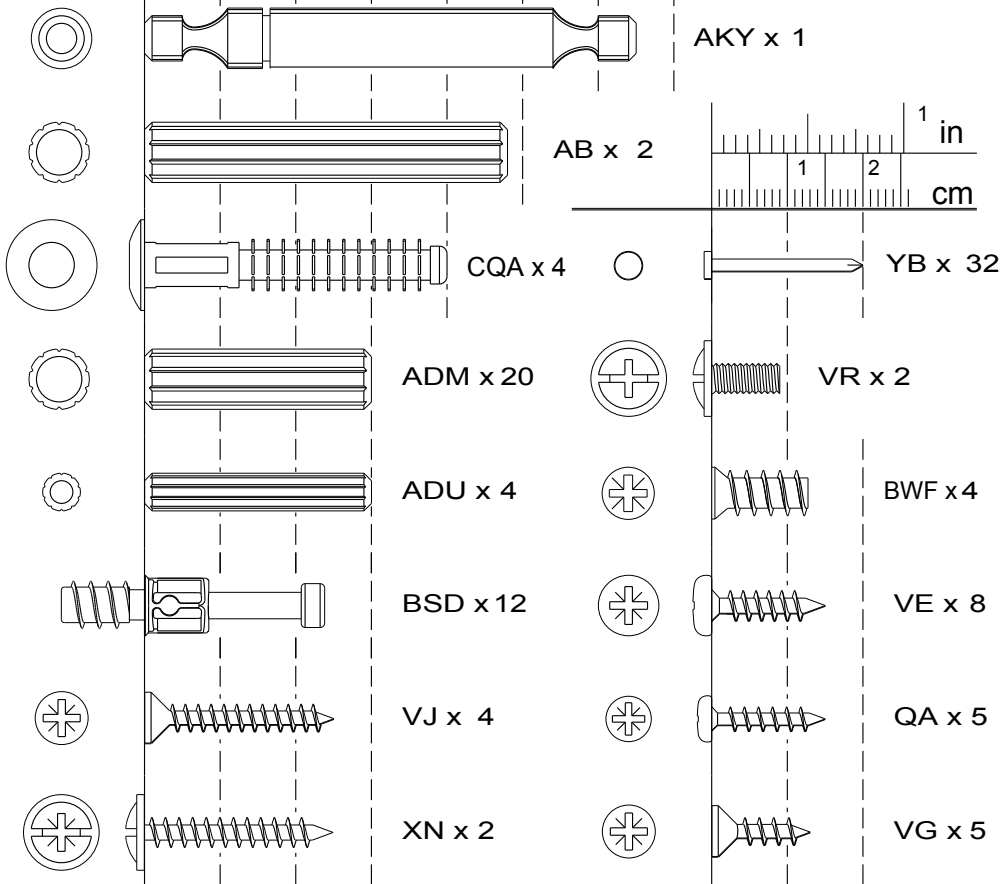
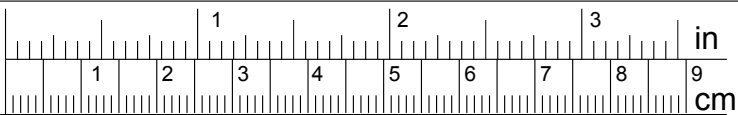
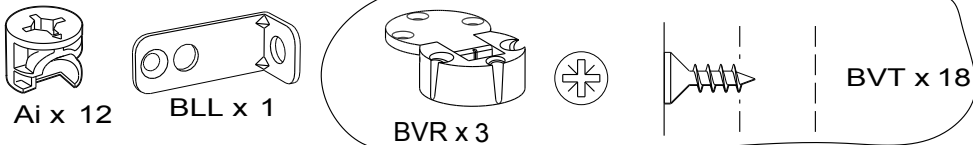
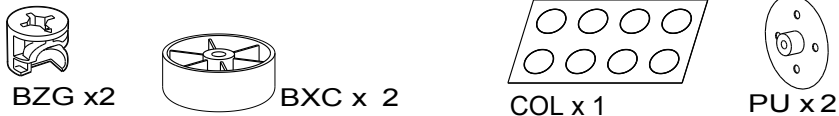
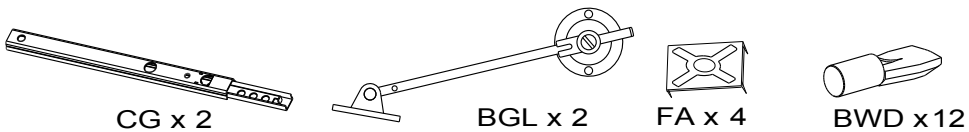

1

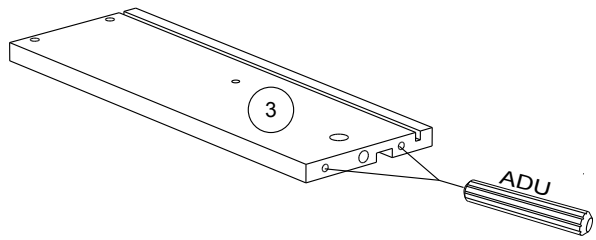
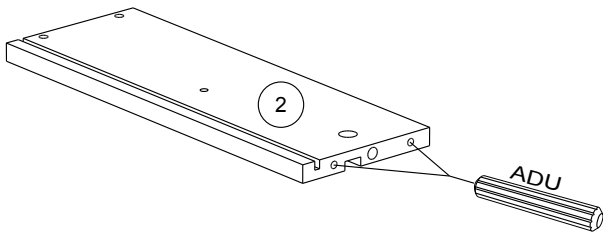
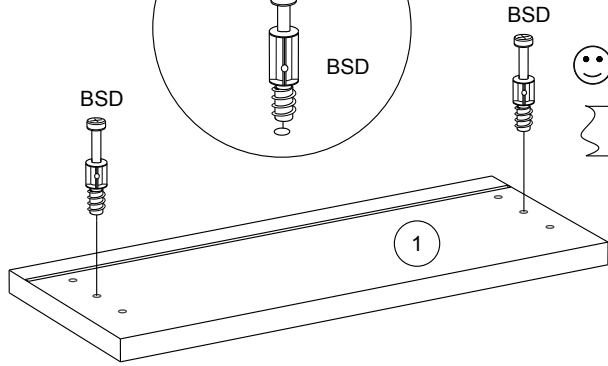
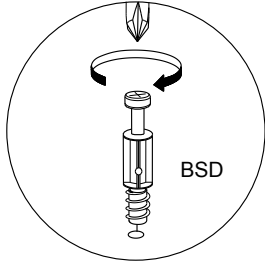
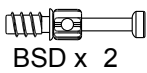

2



BZG x2



CQA x4

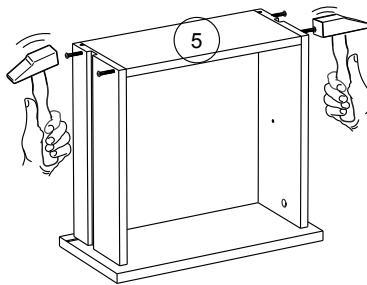
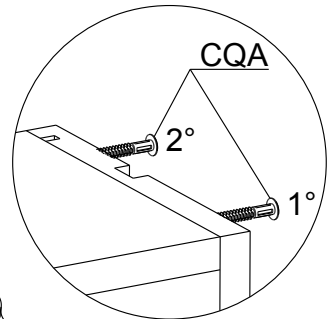
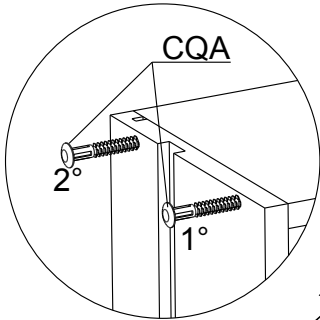
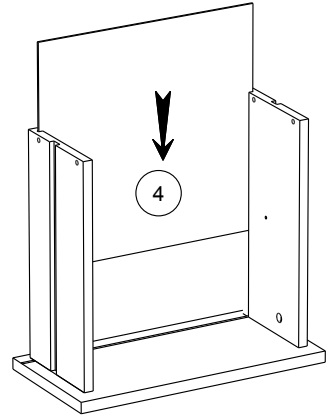
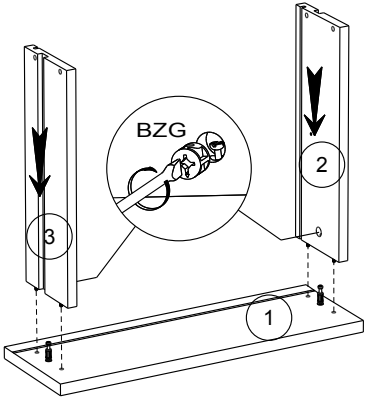

3

ADM x2

BSD x 2

CG x 1

BWF x 2

VG x 2

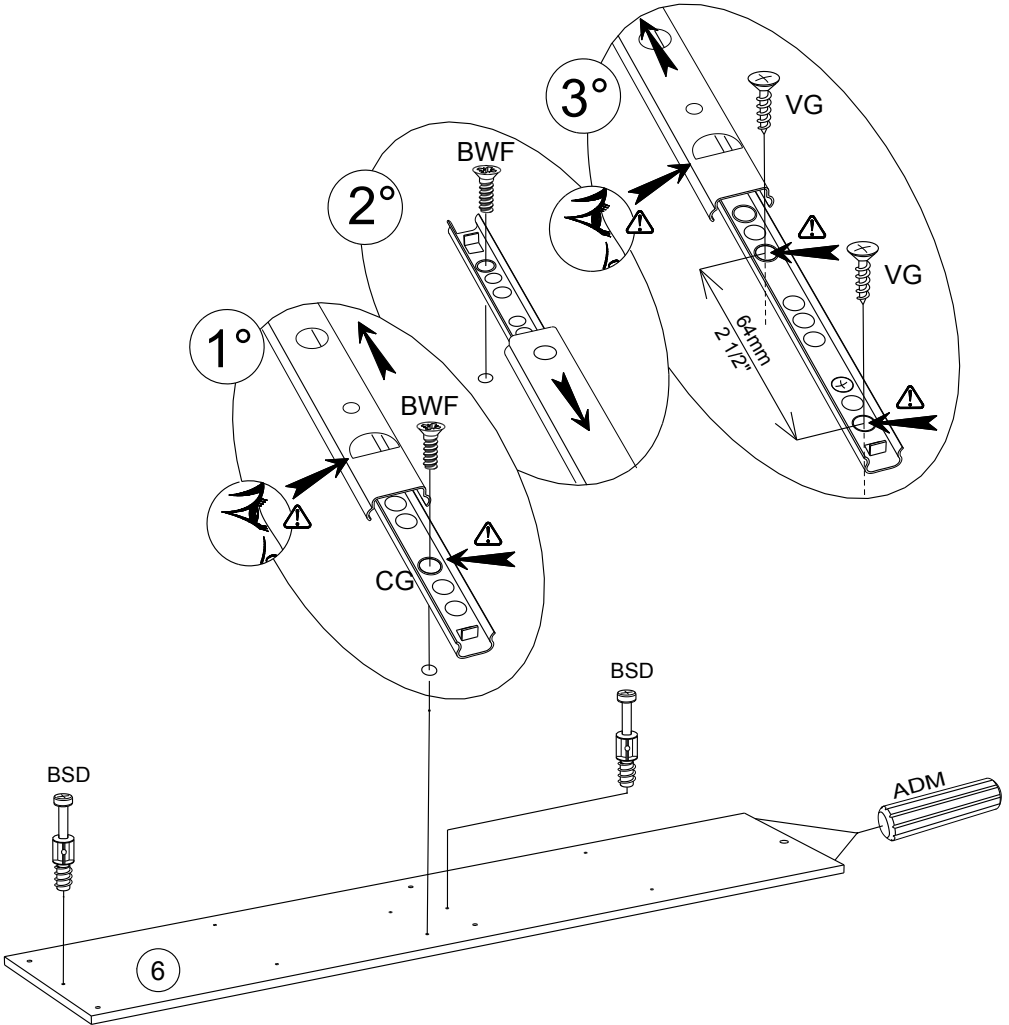

4

ADM x4

CG x 1

BWF x 2

VG x 2

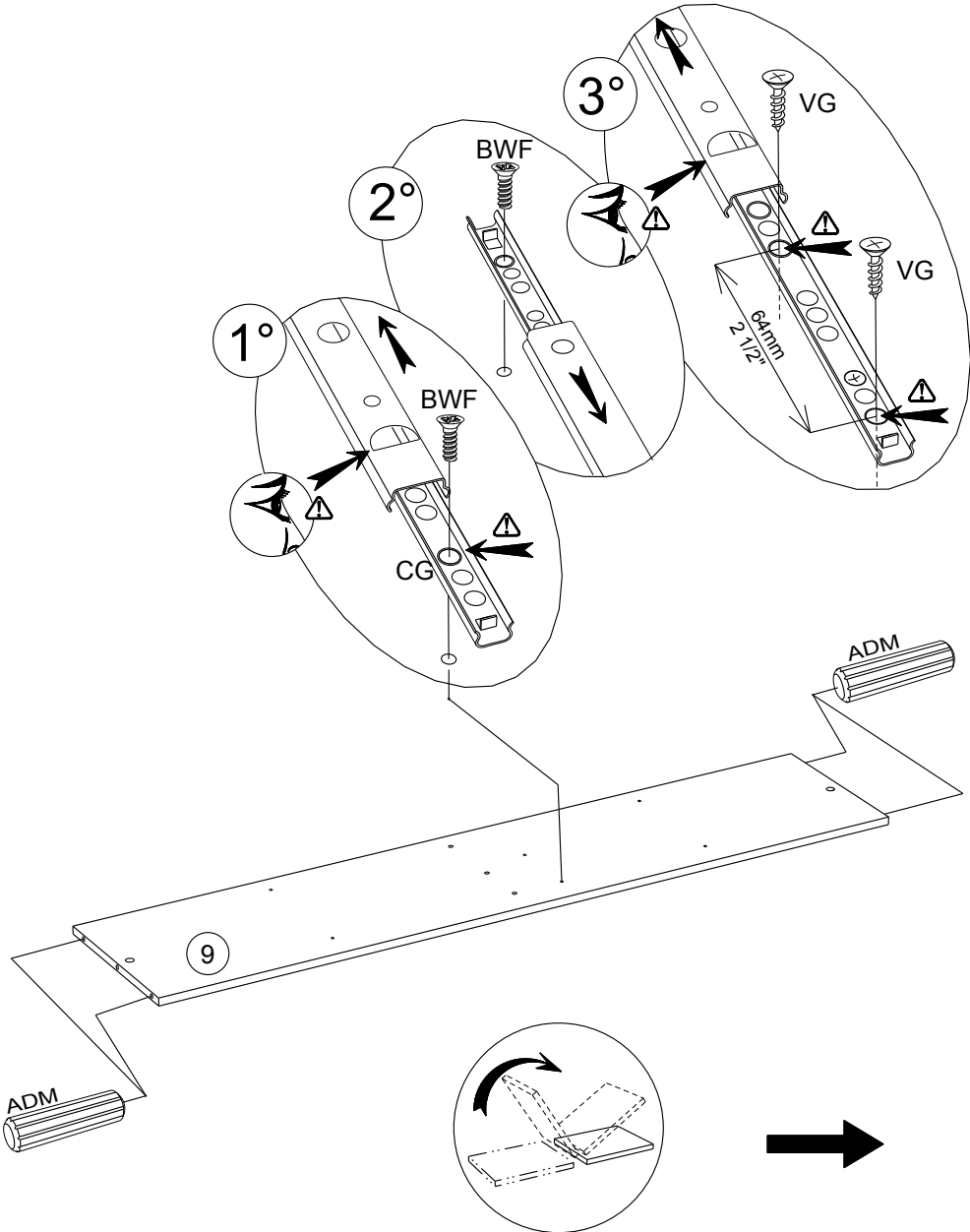



5

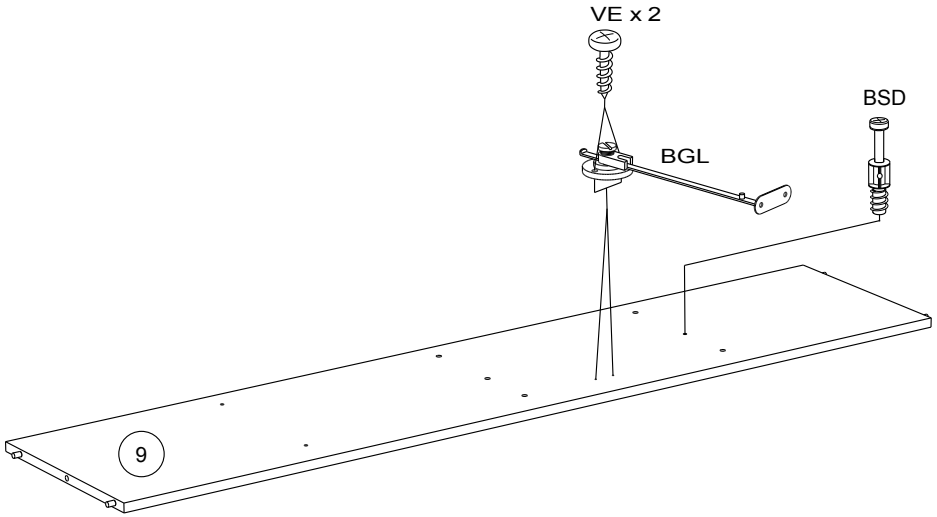
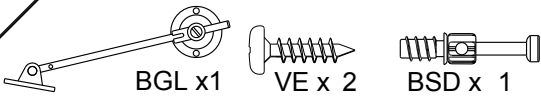

6

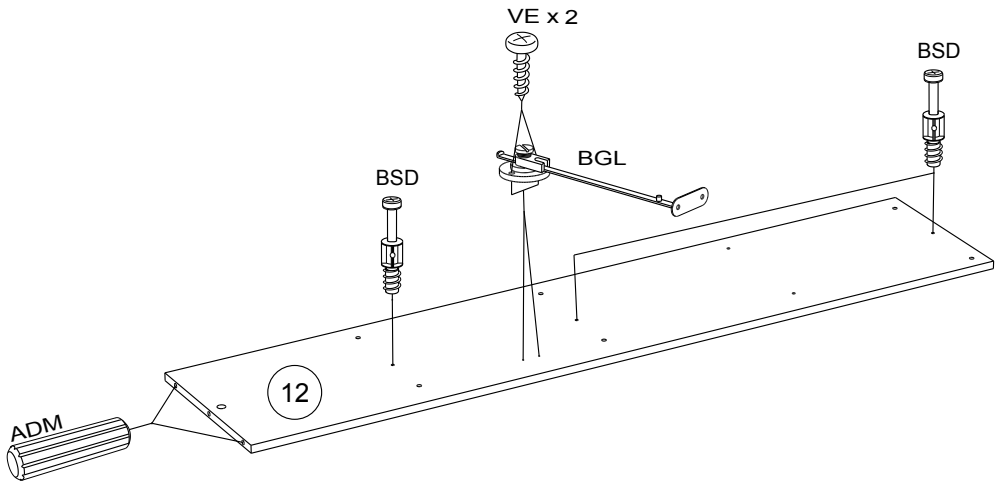
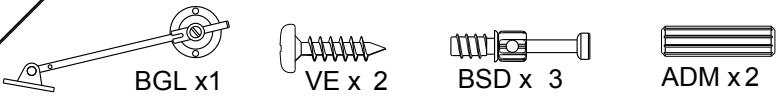

7



BXC x 2

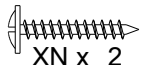

XN x 2



ADM x 4



BSD x 1

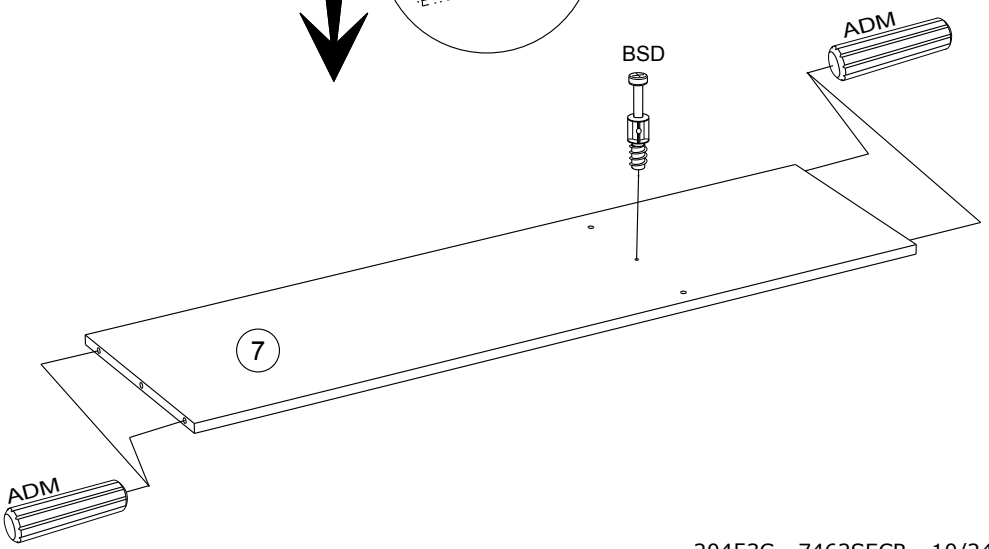
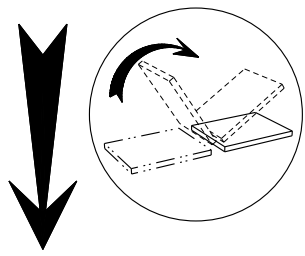
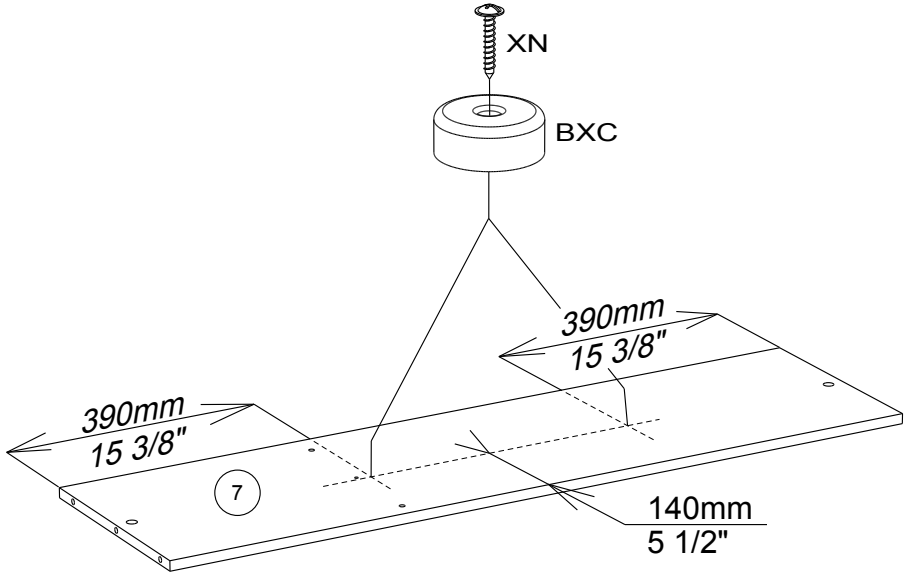

8

ADM x8

AKY x 1

Ai x1

BLL x1

VG x1

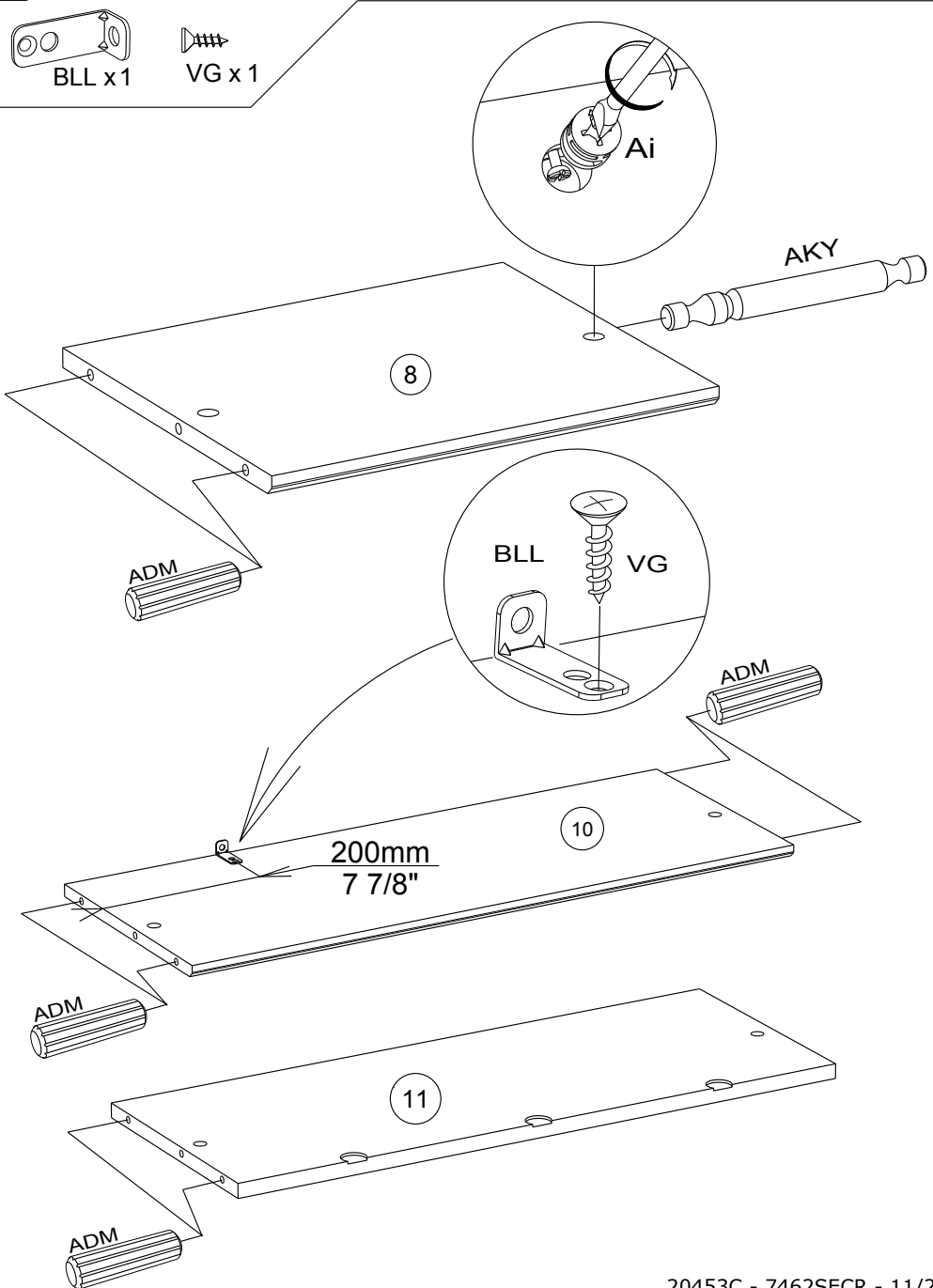

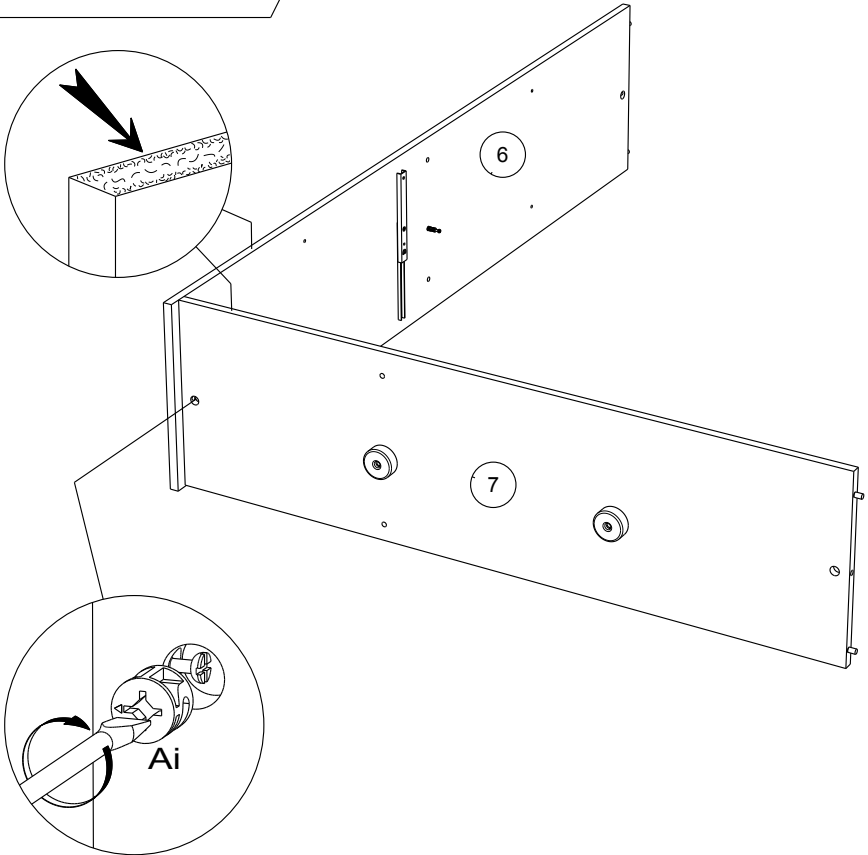
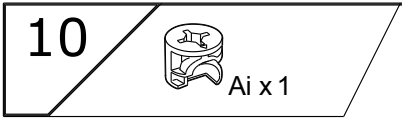
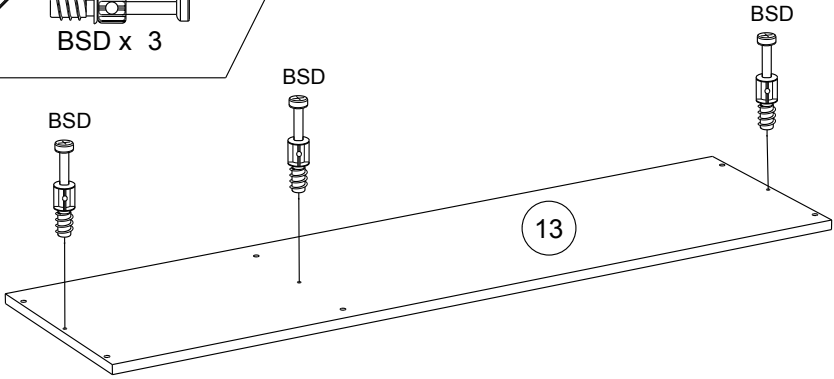
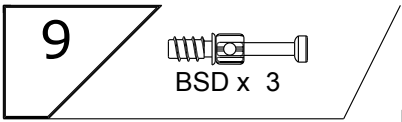

11



Ai x 1

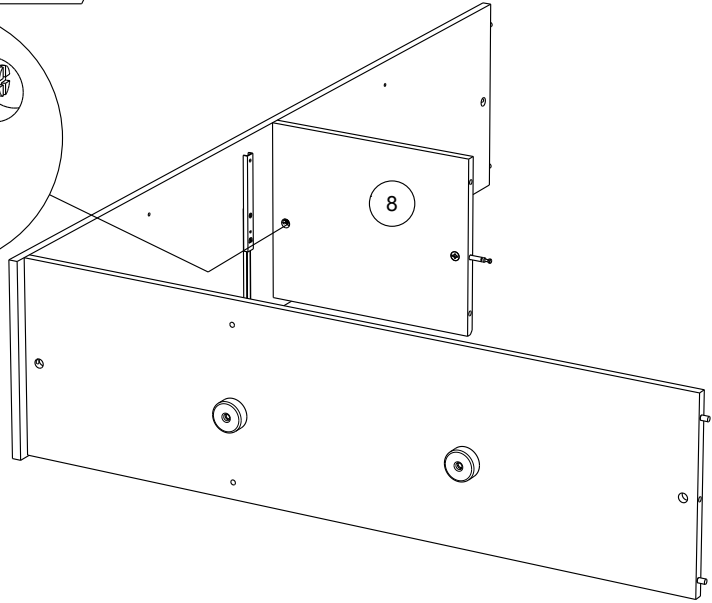
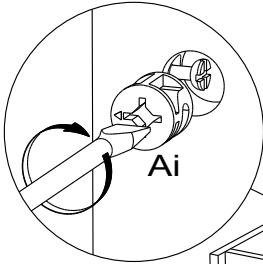

12



Ai x 1

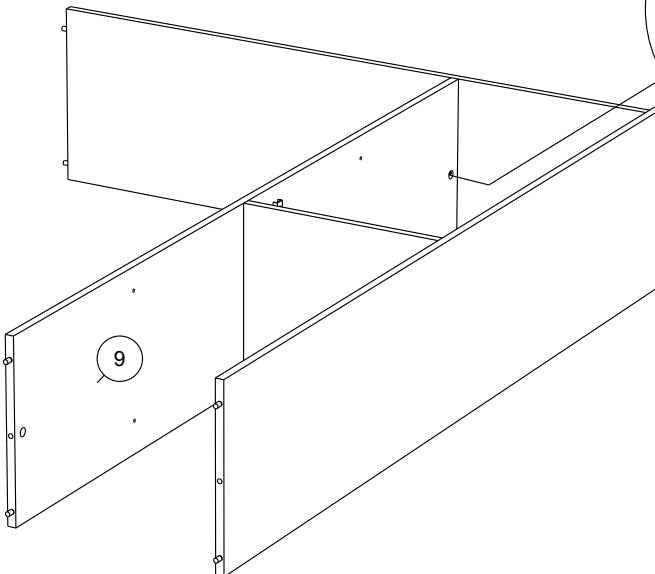
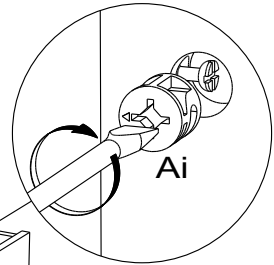

13



AB x 2

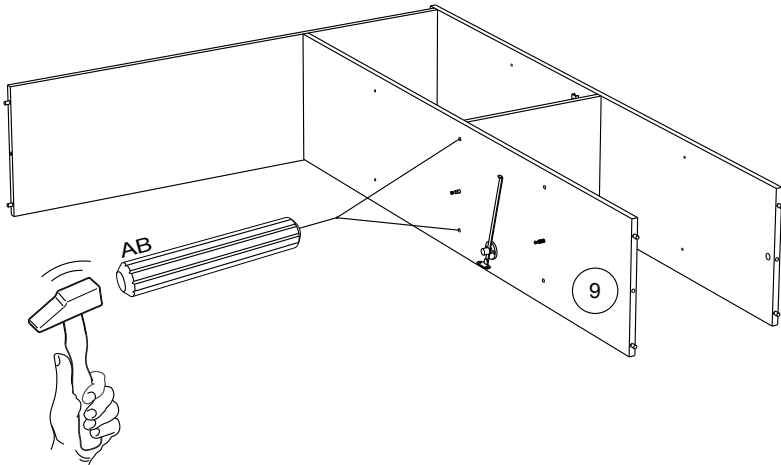

14



Ai x 1

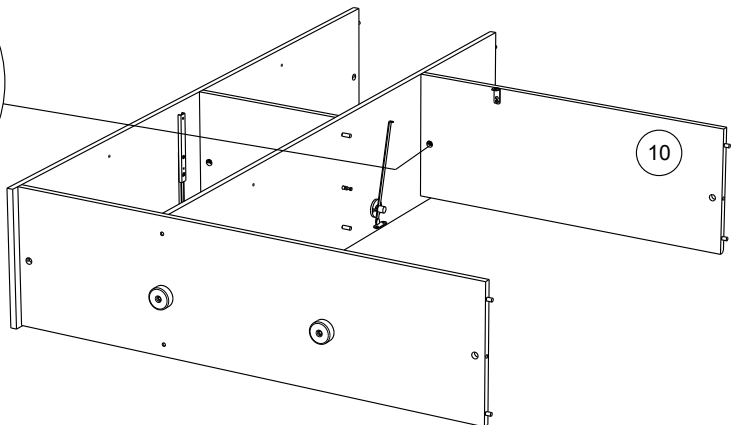
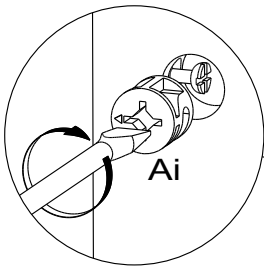

15



Ai x 1

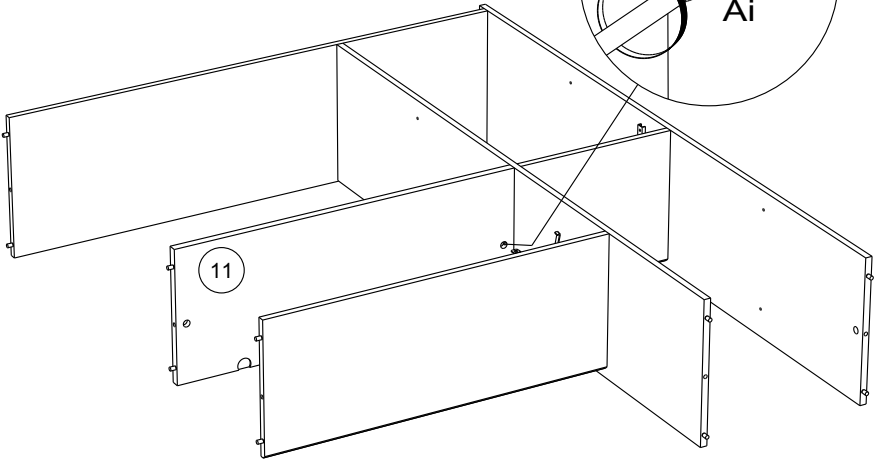

16



Ai x 3

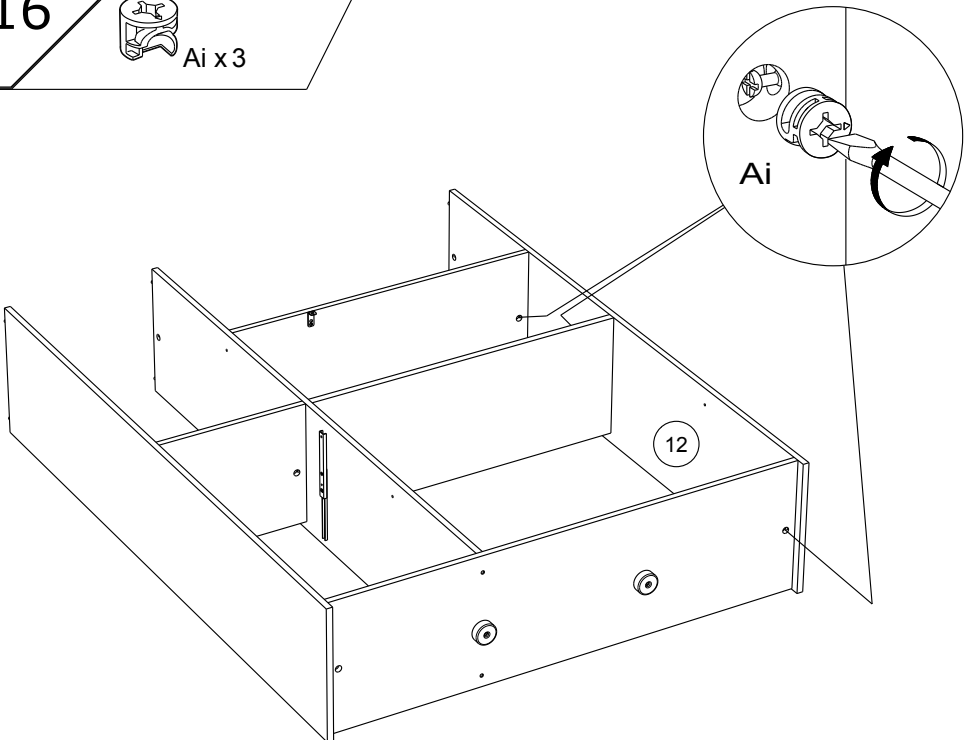

17



Ai x 3

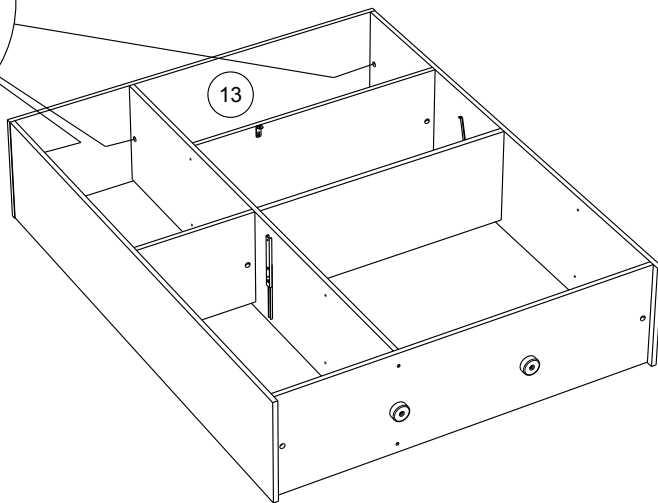
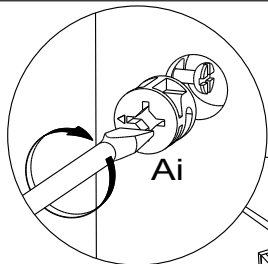

18

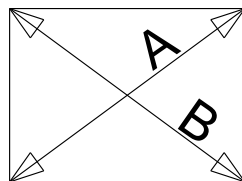

A=B

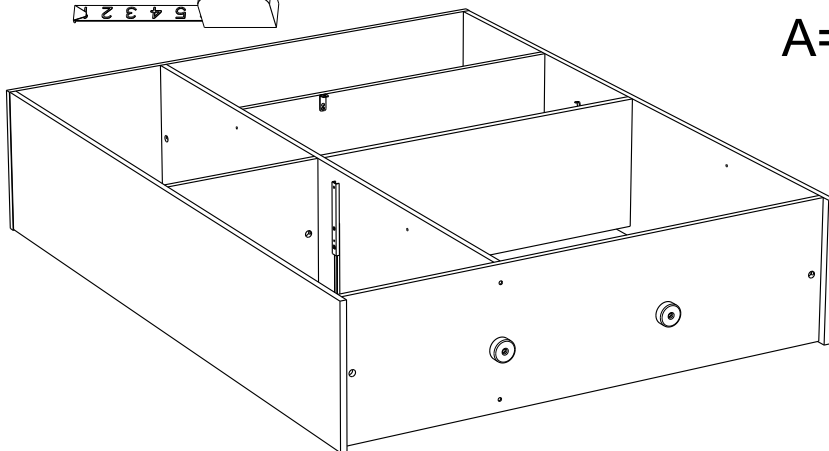



19

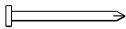

YB x 13

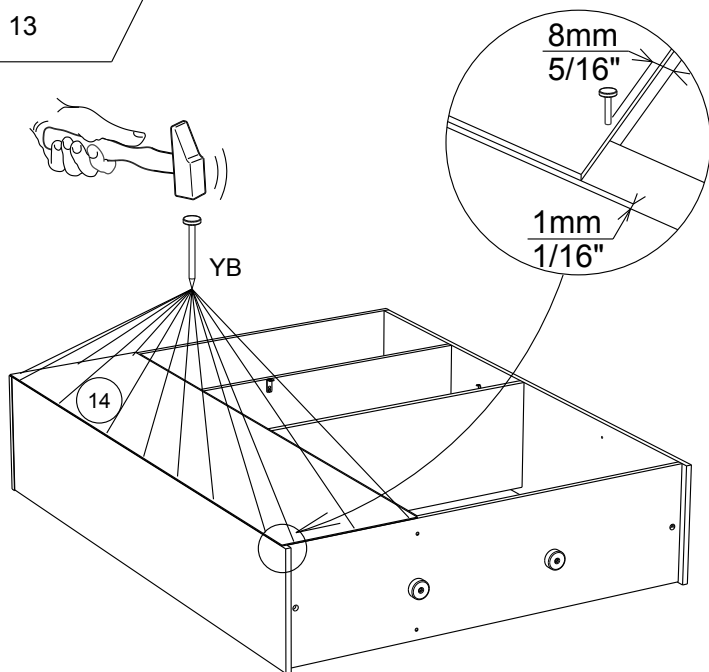

20

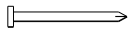

YB x 19

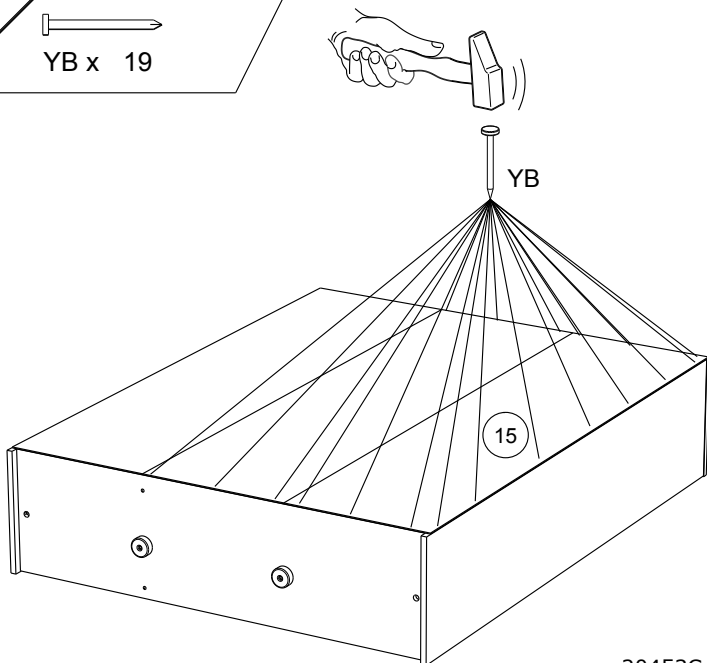

21

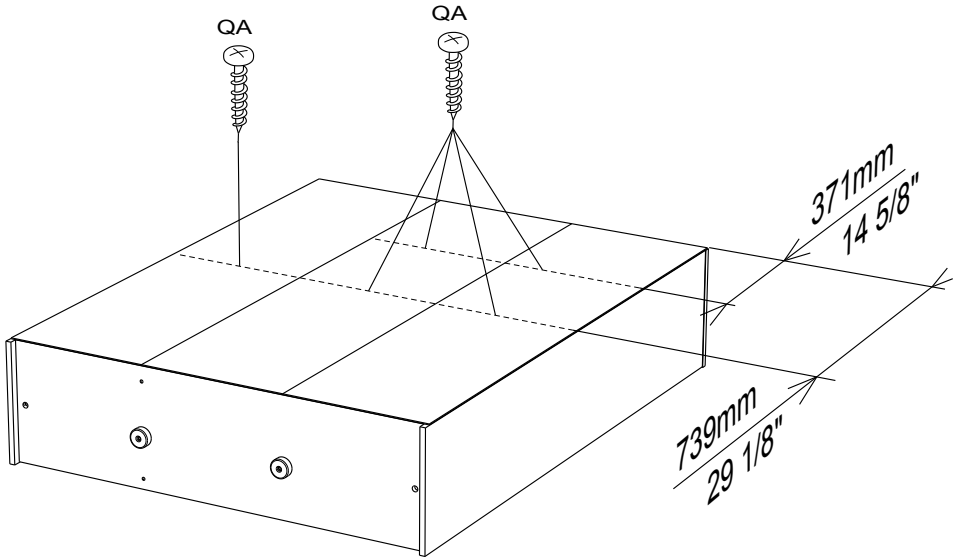
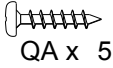

22

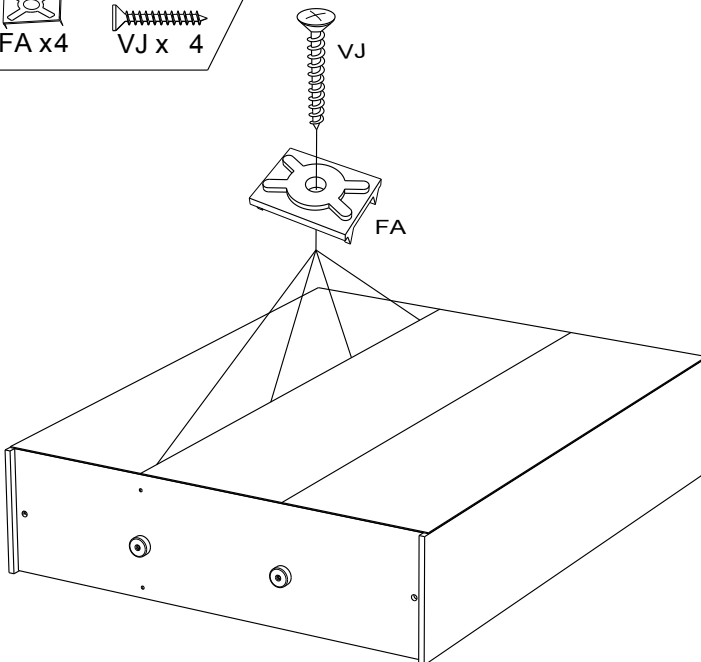
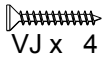

- FR OBLIGATOIRE:** Pour votre sécurité, fixation du meuble au mur.  
Attention, la fixation doit être réalisée par une personne compétente car cela nécessite des chevilles adaptées à la nature de votre mur.
- EN OBLIGATORY:** For your safety, due to risk of overturning, this product must be used with the wall attachment device provided, this should be carried out by a competent person.
- DE OBLIGATORISCH:** Zu Ihrer Sicherheit, befestigen Sie das Möbel an der Wand.  
Achtung: Diese Befestigung ist durch eine fachlich kompetente Person vorzunehmen.  
Hierfür sind für die Bauweise Ihrer Wand geeignete Dübel einzusetzen.
- ES OBLIGATORIO:** Por su seguridad, fijar el meuble a la pared.  
Advertencia: la fijación la ha de llevar a cabo por personal adecuado, ya que requiere el uso de tacos que se adapten al tipo de pared.
- PT OBRIGATÓRIO:** Para sua segurança, fixação do móvel ao muro.  
Atenção: a fixação deverá ser efetuada por pessoa habilitada, visto que são necessárias cavilhas adaptadas ao tipo de parede.
- IT OBBLIGATORIO:** Avvertenza di sicurezza, il fissaggio del mobile a parete deve essere realizzato da una persona competente, in quanto l'operazione richiede l'impiego di tasselli adatti alla natura del muro.
- NL VERPLICHT:** Voor uw veiligheid, bevestiging van het meubel aan de muur.  
Opgelet de bevestiging moet worden uitgevoerd door een bekwaam persoon daar dit voor uw type muur geschikte pluggen vereist.
- CZ POVINNÝ:** Z bezpečnostních důvodů, upevněte nábytek do zdi.  
Pozor, upevnění je třeba svěřit kompetentní osobě, neboť vyžaduje hmoždinky vhodné pro vaši zeď.
- HU KÖTELEZŐ:** Az Ön biztonsága érdekében, a bútor falra rögzítése.  
Figyelmeztetés : a rögzítés csak megfelelő szakképesítéssel rendelkező személy által végezhető el, mert a rögzítéshez a falnak megfelelő csavarokra van szükség.
- PL OBOWIAZKOWY:** Dla bezpieczeństwa, mocowanie mebla do ściany.  
Uwaga, mocowanie musi zostać wykonane przez osobę kompetentną, ponieważ wymaga to zastosowania kołków dostosowanych do rodzaju ściany.
- RO OBLIGATORIU:** Pentru securitatea dumneavoastră, fixarea mobilierului de perete.  
Atenție, fixarea trebuie să fie realizată de o persoană calificată, deoarece sunt necesare dispozitive de fixare adaptate caracteristicilor peretelui dumneavoastră
- RU ОБЯЗАТЕЛЬНЫЙ :** Для вашей безопасности Крепление мебели к стене  
Внимание! Крепление должно производиться опытным специалистом, т.к. для такой установки потребуются штифты, соответствующие типу вашей стены.
- SK POVINNÉ:** Z bezpečnostných dôvodov, nábytok upevnite k stene.  
Dbajte na to, aby upevnenie vykonala kompetentná osoba, pretože pri upevňovaní sa vyžadujú kolíky vhodné do materiálu, z ktorého je stena vyrobená.
- SL OBVEZNO:** Za vašo varnost, Enota naj bo pritrjena na steno. Pozor: To naj stori kompetentna oseba, ker je potrebno uporabiti pravilni nosilec glede na vrsto stene ki jo uporabljate.
- TR ZORUNLU:** Güvenliğinizi için, Mobilyanın duvara sabitlenmesi  
Dikkat, sabitleme işlemleri uzman biri tarafından yapılmalıdır çünkü bu işlem için duvarınızın malzemesine uygun dübellerin kullanılması gerekmektedir
- EL ΥΠΟΧΡΕΩΤΙΚΟΣ :** Για την ασφάλειά σας στερέωση των επιπέδων στον τοίχο.  
Προσοχή, η στερέωση πρέπει να γίνεται από ικανό άτομο, καθώς απαιτούνται σφίγγες προσαρμοσμένες στη φύση του τοίχου σας.
- AR واجب :** لسلامتك الشخصية, تثبيت قطعة الأثاث على الحائط  
تحذير، يجب أن يقوم شخص متخصص بعملية التثبيت على الحائط إذ أنها تتطلب اسفينا معيناً يتوافق مع طبيعة الحائط نفسه.
- ZH 義務性 :** 为了您的安全，本产品必须靠墙安装。  
NB 本产品必须由专业人士安装，且您必须使用符合您的墙壁类型的罗威纤维管。

23

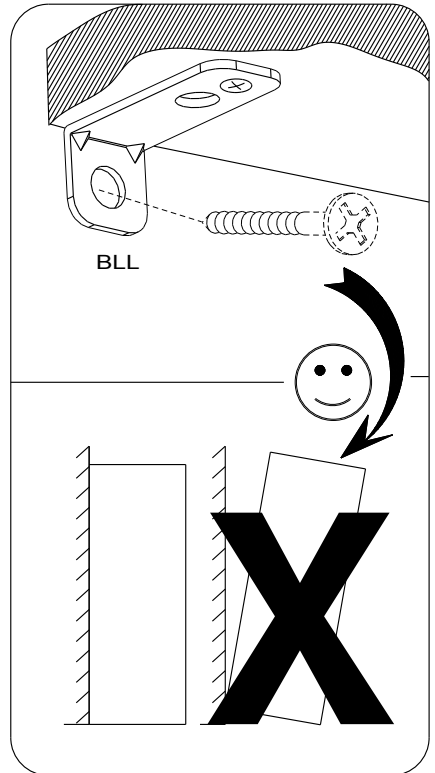
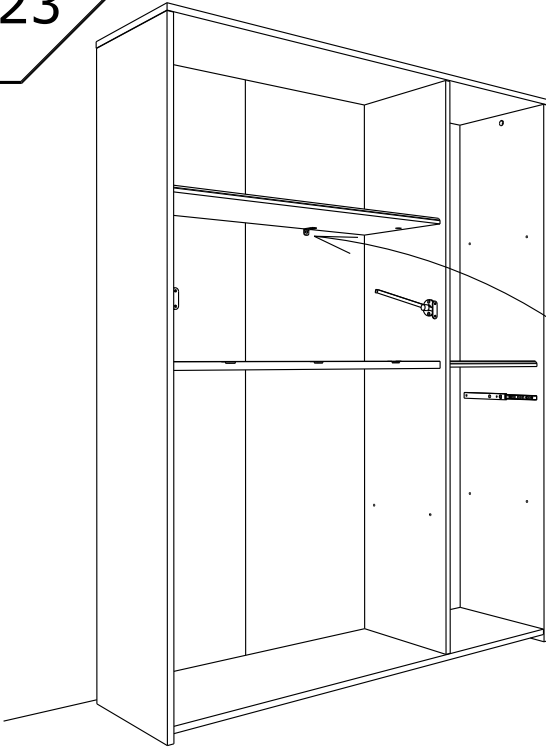

24



BVR x3



BVT x9

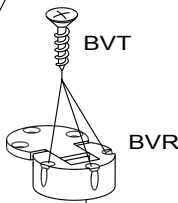

BVT

BVR

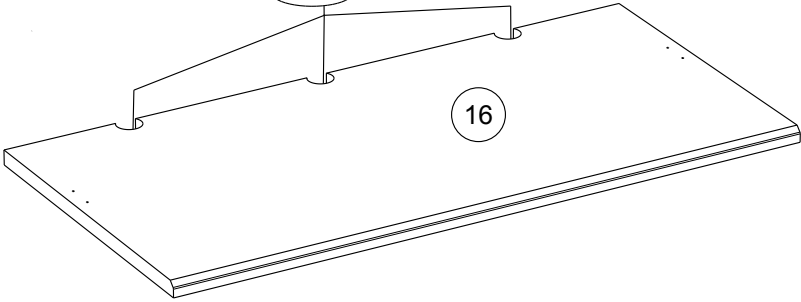
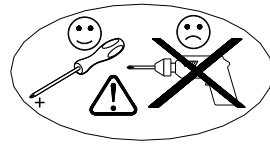

16

25

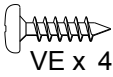

VE x 4



BVT x9

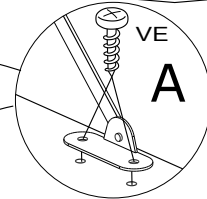
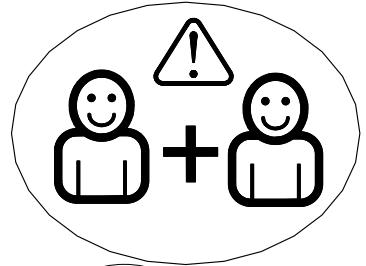
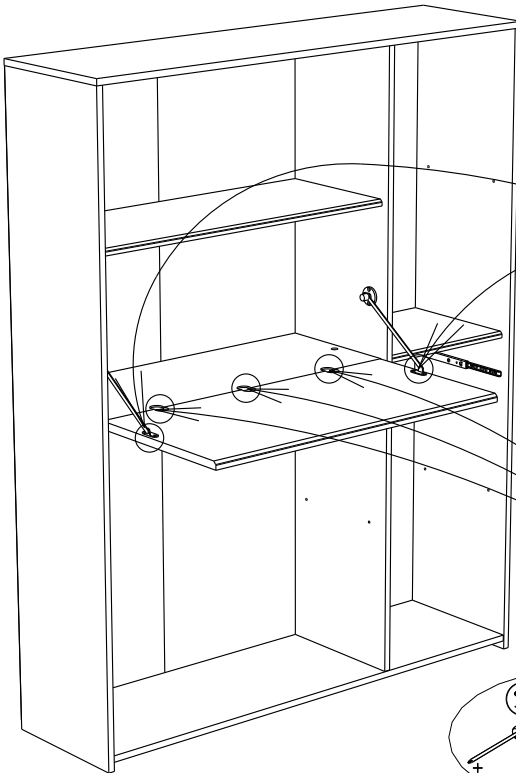

VE

A

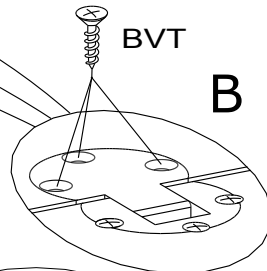

BVT

B

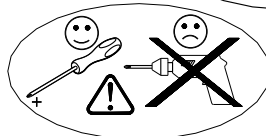

26



BWD x 12

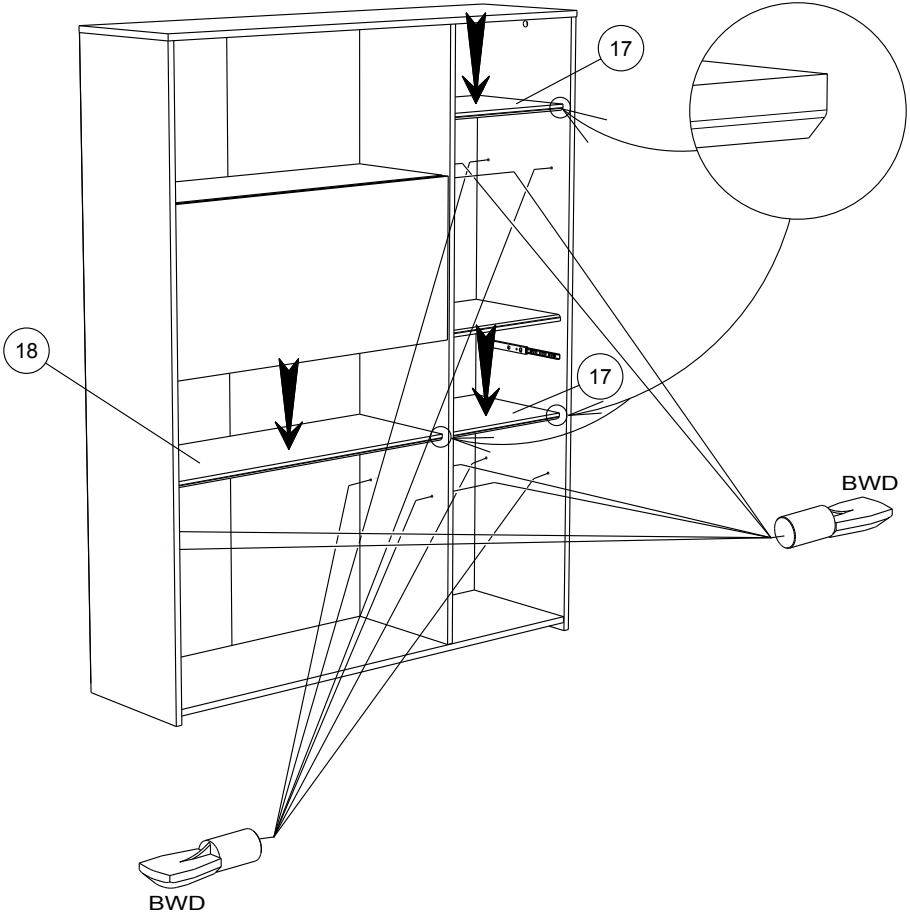
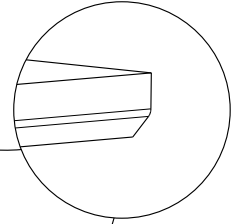
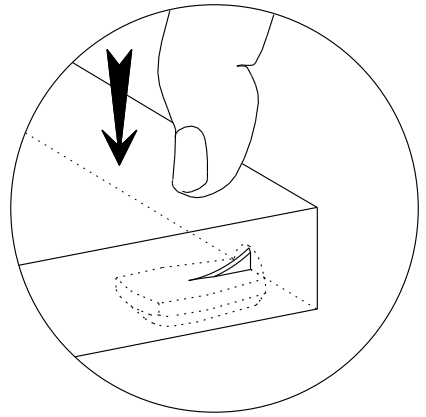

27

VR x 2

COL x 1

PU x 2

