

# 0673ENFI

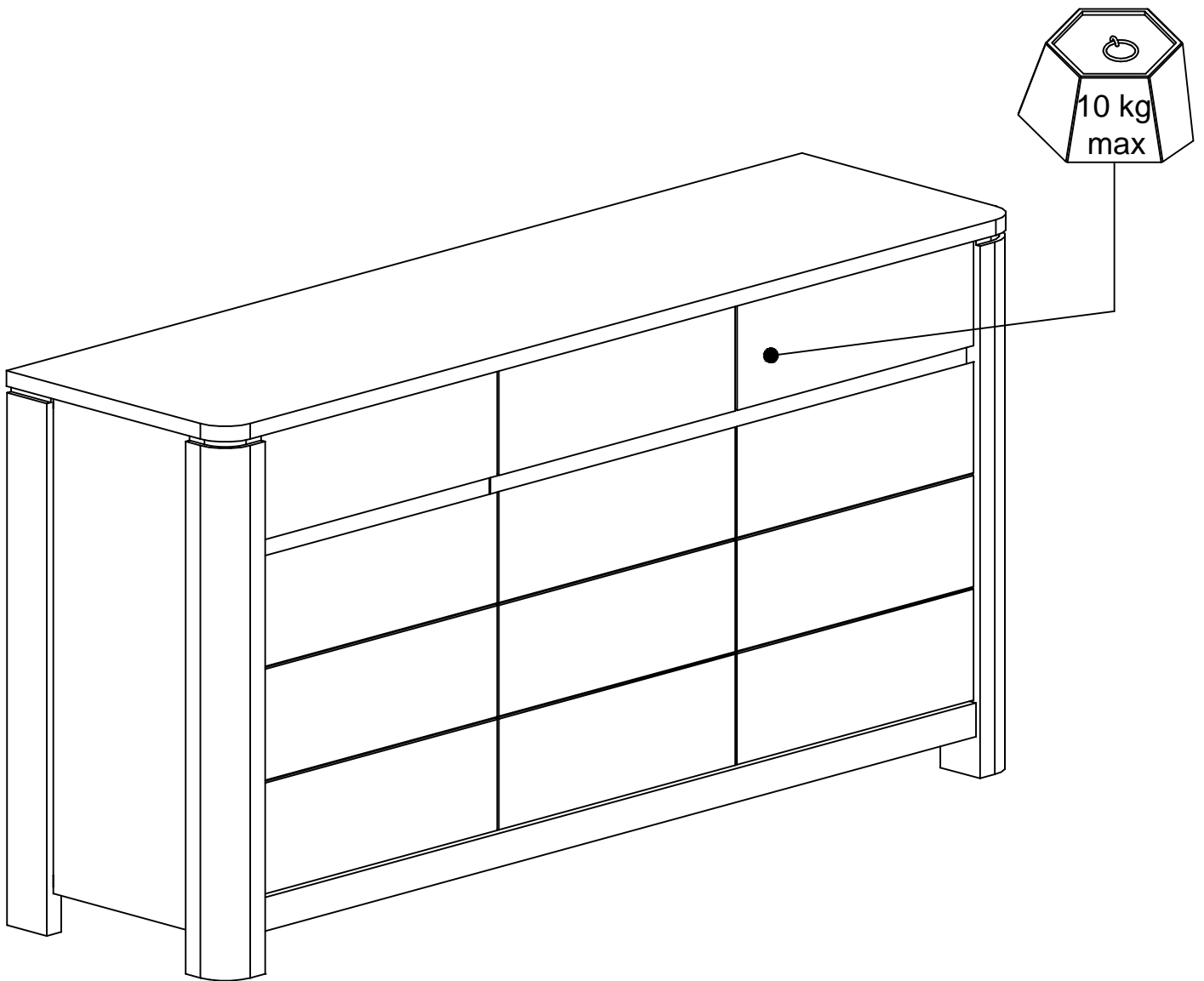

Code: 777 394 69

Décor/Finitions: Chêne nature

Gamme: MALO

**ARTE MOB**  
international

**FR Remerciements:**

Nous vous remercions d'avoir choisi un meuble créé et fabriqué par Artemob International et espérons qu'il vous donnera entière satisfaction

**EN Thanks:**

Thank you for choosing furniture designed and manufactured by Artemob International. We hope you are totally satisfied with your purchase

**DE Danksagung:**

Wir danken Ihnen für den Kauf eines Frankreich von der Artemob International entworfenen und hergestellten Möbelstücks und hoffen, dass Sie es zu Ihrer vollkommenen Zufriedenheit finden werden

**ES Agradecimientos:**

Les damos las gracias por haber elegido un mueble diseñado y fabricado por Artemob International y esperamos que sea de su total agrado.

**PT Agradecimentos:**

Obrigado por ter escolhido um móvel concebido e fabricado pelo Artemob International, esperando que seja do seu inteiro agrado.

**IT Ringraziamenti:**

Grazie per avere scelto un mobile progettato e fabbricato da Artemob International. Speriamo soddisfatti appieno le vostre esigenze.

**NL Bedankje:**

Wij bedanken u voor de aankoop van een door de Artemob International ontworpen en vervaardigd meubel en hopen dat u er veel plezier aan zult beleven.

**RU Благодарность:**

Мы благодарим вас за то, что вы выбрали мебель, созданную и произведенную Artemob International, и надеемся, что вы будете полностью удовлетворены нашей продукцией.

**PL Podziękowania:**

Dziękujemy za wybór mebli stworzonych i wyprodukowanych przez Artemob International. Mamy nadzieję że będziecie Państwo w pełni zadowoleni z zakupu.

**SK Pod'akovanie:**

Ďakujeme, že ste si vybrali nábytok navrhnutý a vyrobený spoločnosťou Artemob International. Dúfame, že budete svojim nákupom absolútne spokojní.

**CS Poděkování:**

Děkujeme, že jste si vybrali nábytek navržený a vyrobený společností Artemob International. Doufáme, že budete svým nákupem naprosto spokojeni.

**HU Köszönet:**

Köszönjük, hogy a Artemob International által létrehozott és gyártott bútort választott, reméljük, hogy elégedett lesz a termékkel.

**RO Mulțumiri:**

Vă mulțumim că ați ales un articol de mobilier conceput și fabricat de Artemob International și sperăm că veți fi pe deplin satisfăcuți de acesta.

**TR Teşekkür ederiz:**

Artemob International tarafından tasarlanan ve üretilen bu mobilyayı seçtiğiniz için teşekkür ederiz. Ürününüzden memnun kalmanızı ümit ederiz.

**AR ركش:**

ابريزو مركزشذ تخلايارمك هذه المعطلا نم الثالث نم مصنيم  
وى نمئذ نأ انتل Artemob International ونصنيم المعومج  
راضه مكم.

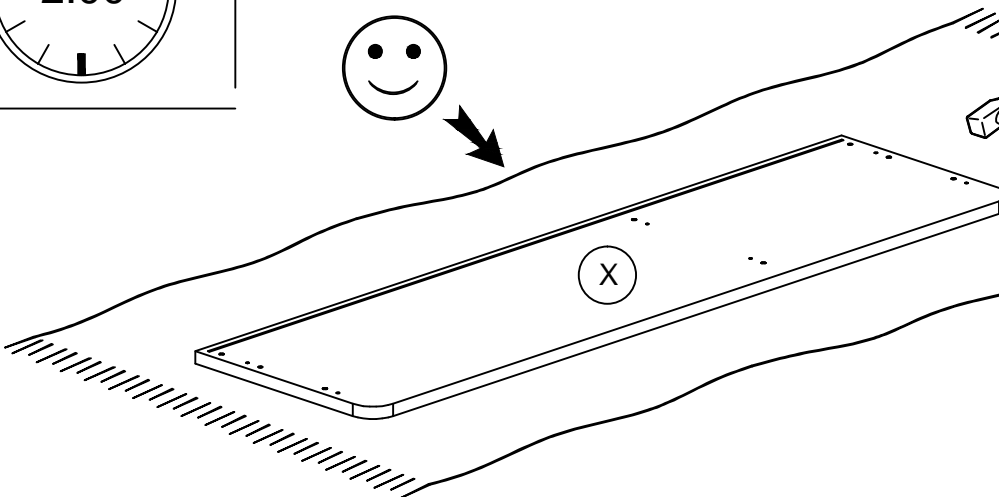
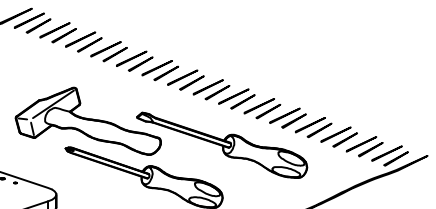
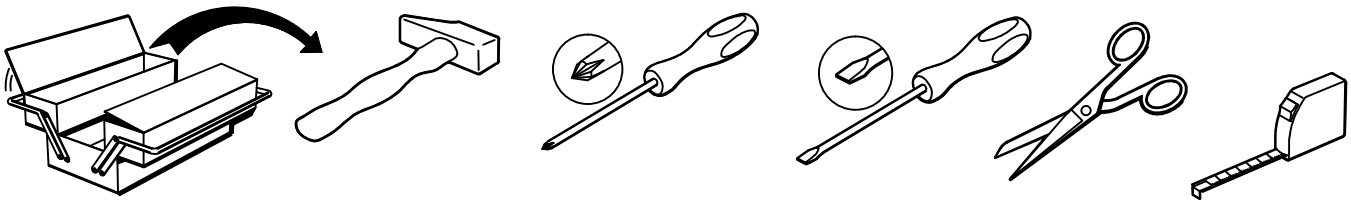

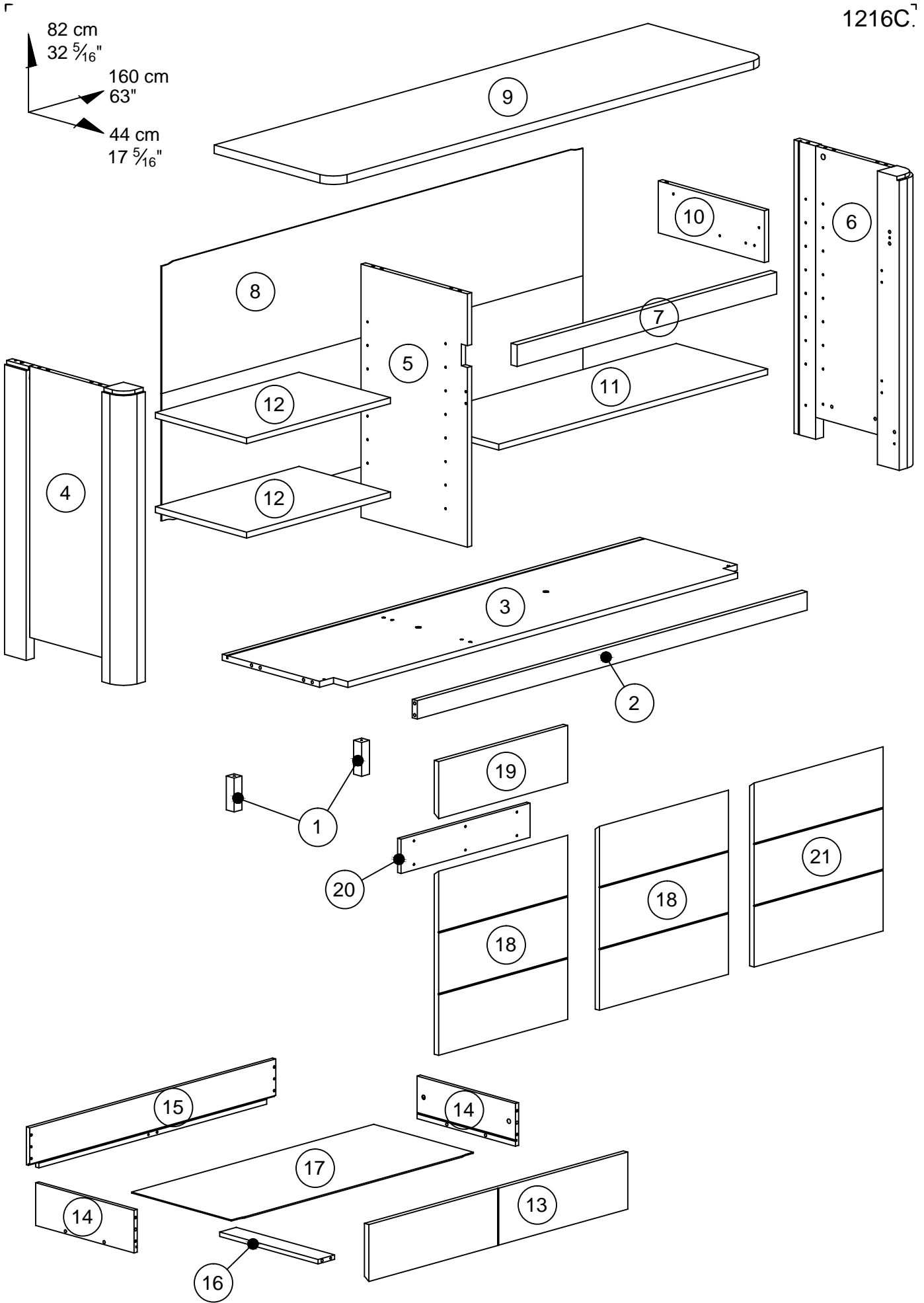

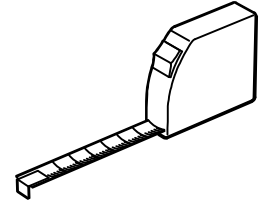

0673ENFI			mm			inch					
①	x	2	92	29	29	3	5/8	1	1/8	1	1/8
④	x	1	797	438	79	31	3/8	17	1/4	3	1/8
⑤	x	1	688	392	16	27	1/16	15	7/16		5/8
⑥	x	1	797	438	79	31	3/8	17	1/4	3	1/8
⑦	x	1	958	592,5		37	11/16	2	5/16		3/4
⑩	x	1	141	392	16	5	9/16	15	7/16		5/8
⑬	x	1	955	155	16	37	5/8	6	1/8		5/8
⑭	x	2	363	116	12	14	5/16	4	9/16		1/2
⑮	x	1	908	116	12	35	3/4	4	9/16		1/2
⑯	x	1	363	61	12	14	5/16	2	3/8		1/2
⑱	x	2	476	500	16	18	3/4	19	11/16		5/8
⑲	x	1	476	155	16	18	3/4	6	1/8		5/8
⑳	x	1	476	93	12	18	3/4	3	11/16		1/2
㉑	x	1	476	500	16	18	3/4	19	11/16		5/8
②	x	1	1438	50	17	56	5/8	1	15/16		11/16
③	x	1	1540	414	16	60	5/8	16	5/16		5/8
⑧	x	1	1554	351	5	61	3/16	13	13/16		3/16
⑨	x	1	1600	440	23	63		17	5/16		7/8
⑪	x	1	992	337	16	39	1/16	13	1/4		5/8
⑫	x	2	530	337	16	20	7/8	13	1/4		5/8
⑰	x	1	893	372	2,5	35	3/16	14	5/8		1/8

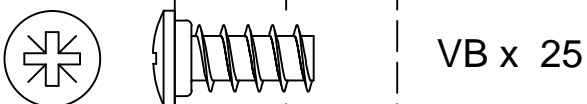
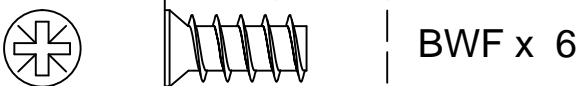
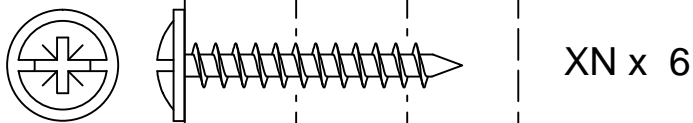
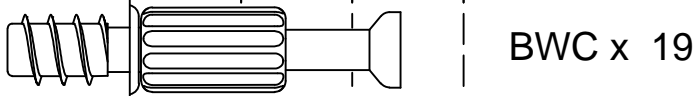
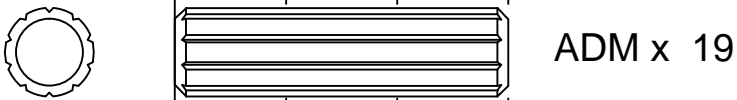
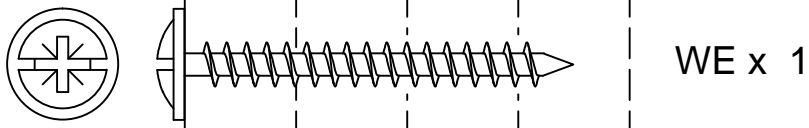
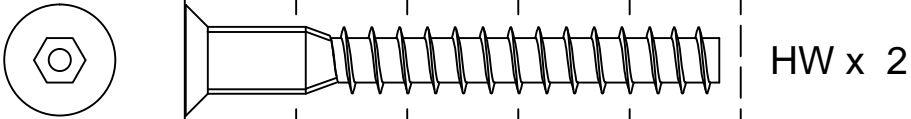
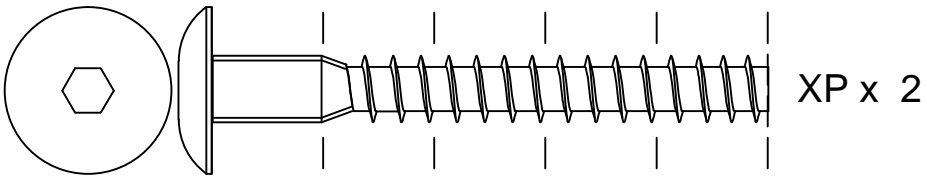
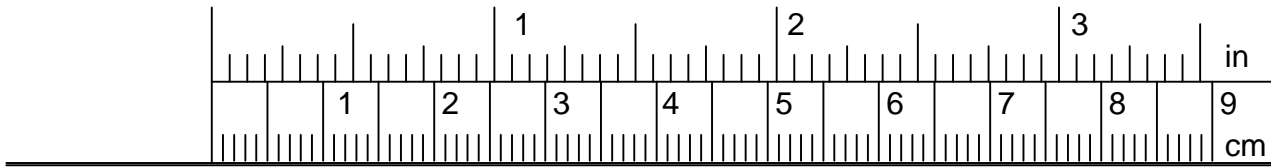



Ai x 13



BZG x 6

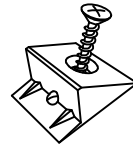

ZYY x 5

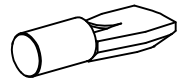

BWD x 12

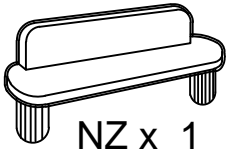

NZ x 1

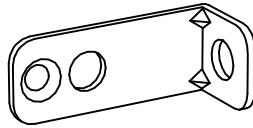

BLL x 13

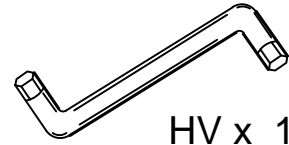

HV x 1

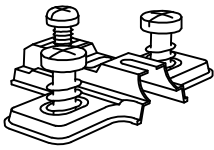

BWU x 7

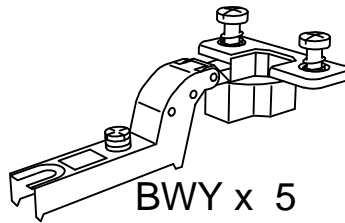

BWY x 5

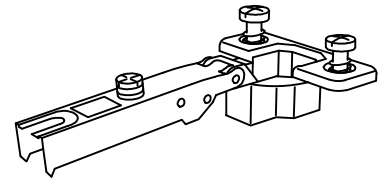

BWW x 2

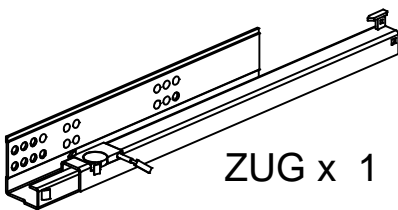

ZUG x 1

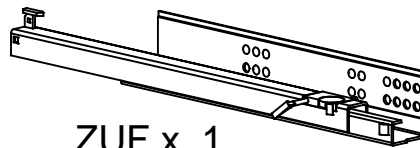

ZUF x 1



AQO x 3

1

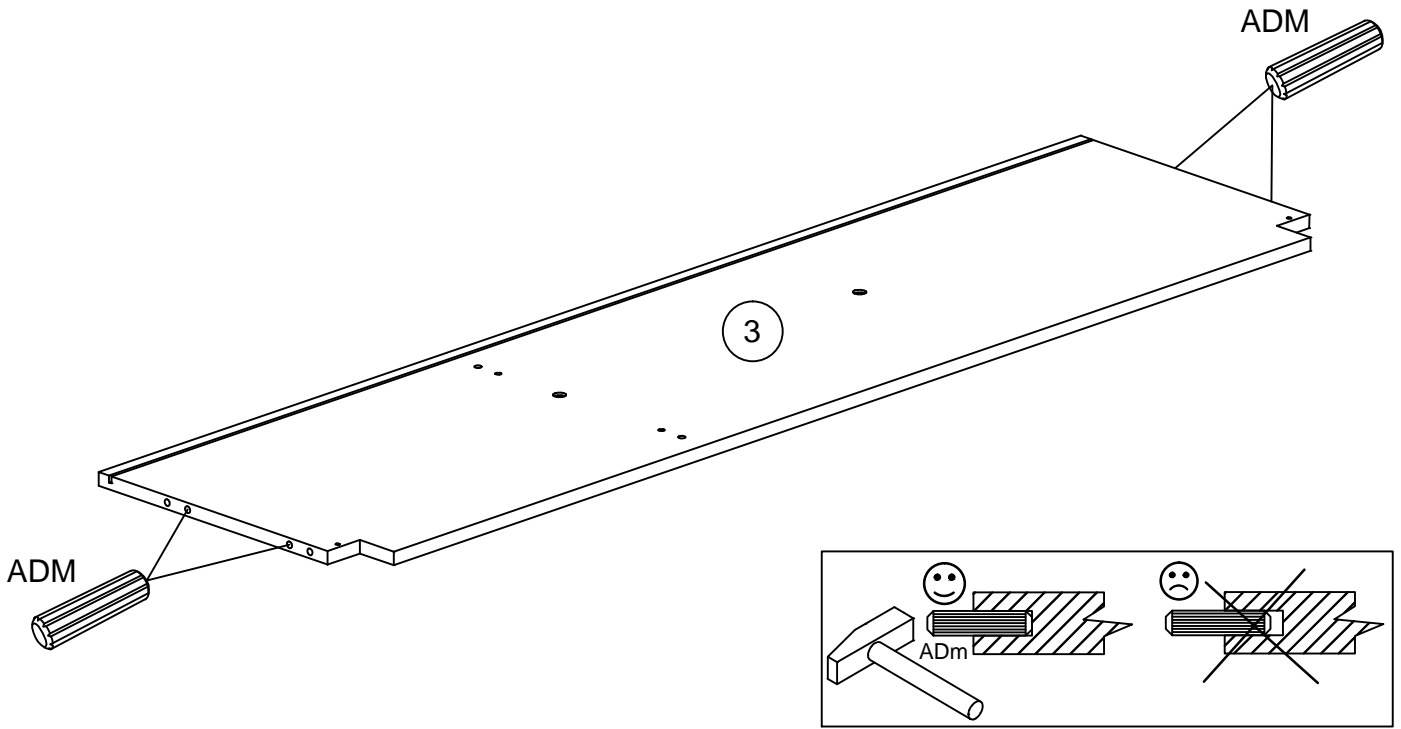
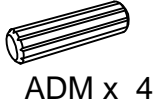

2

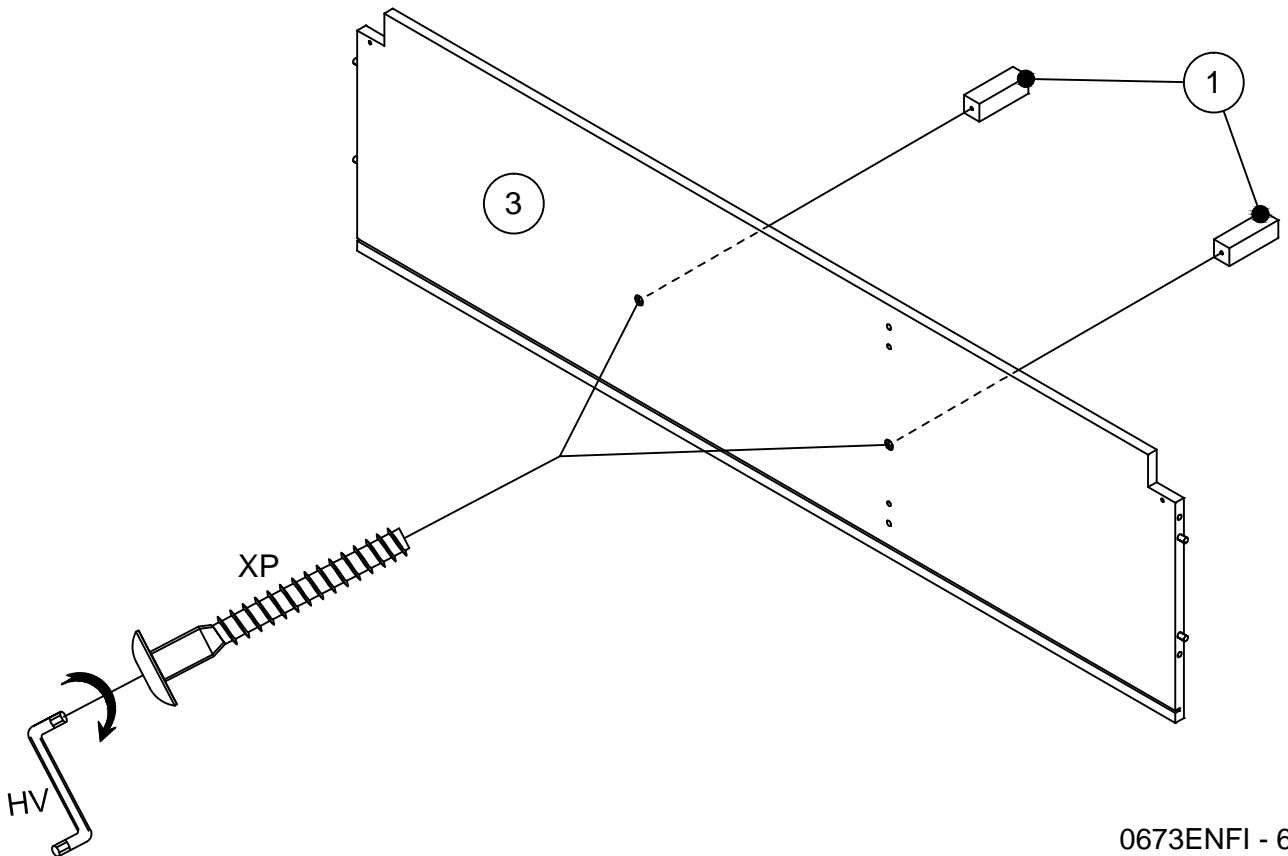
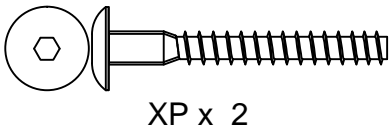

3

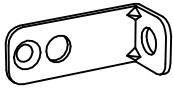

BLL x 4



VB x 4

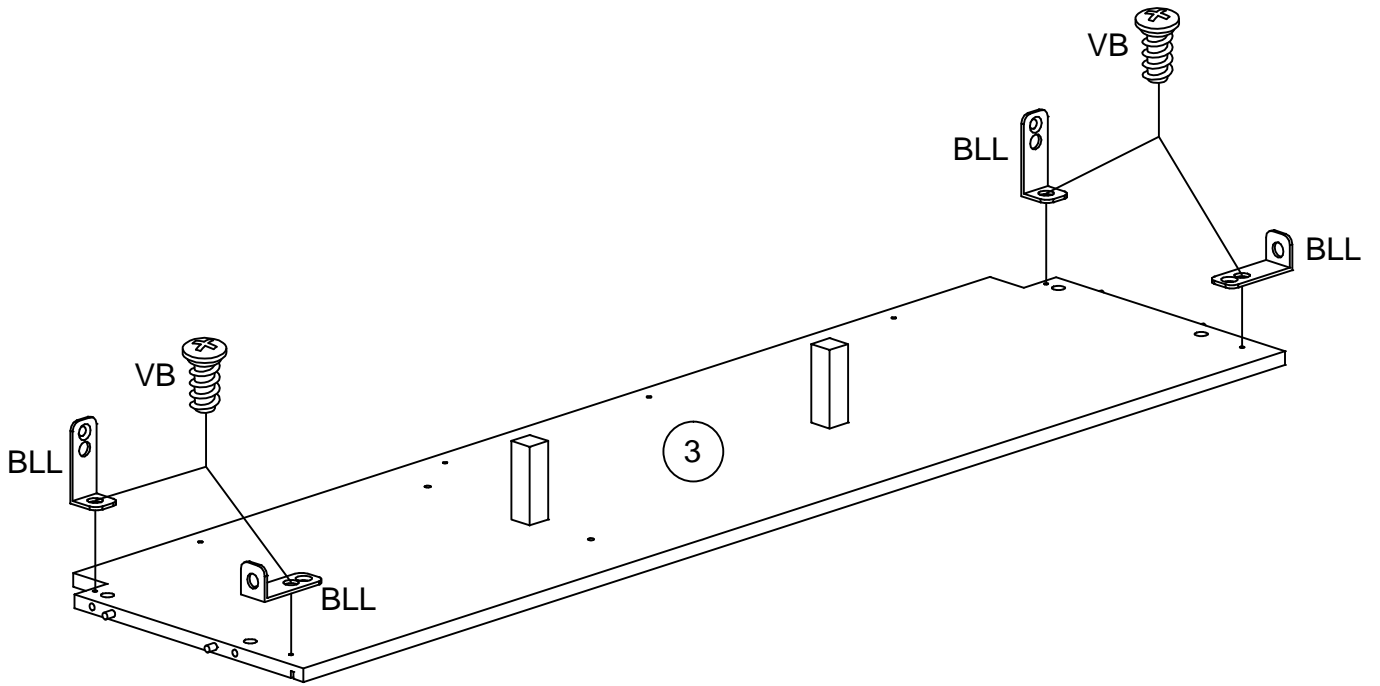

4



BWC x 3



ADM x 3

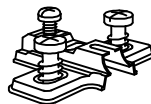

BWU x 3

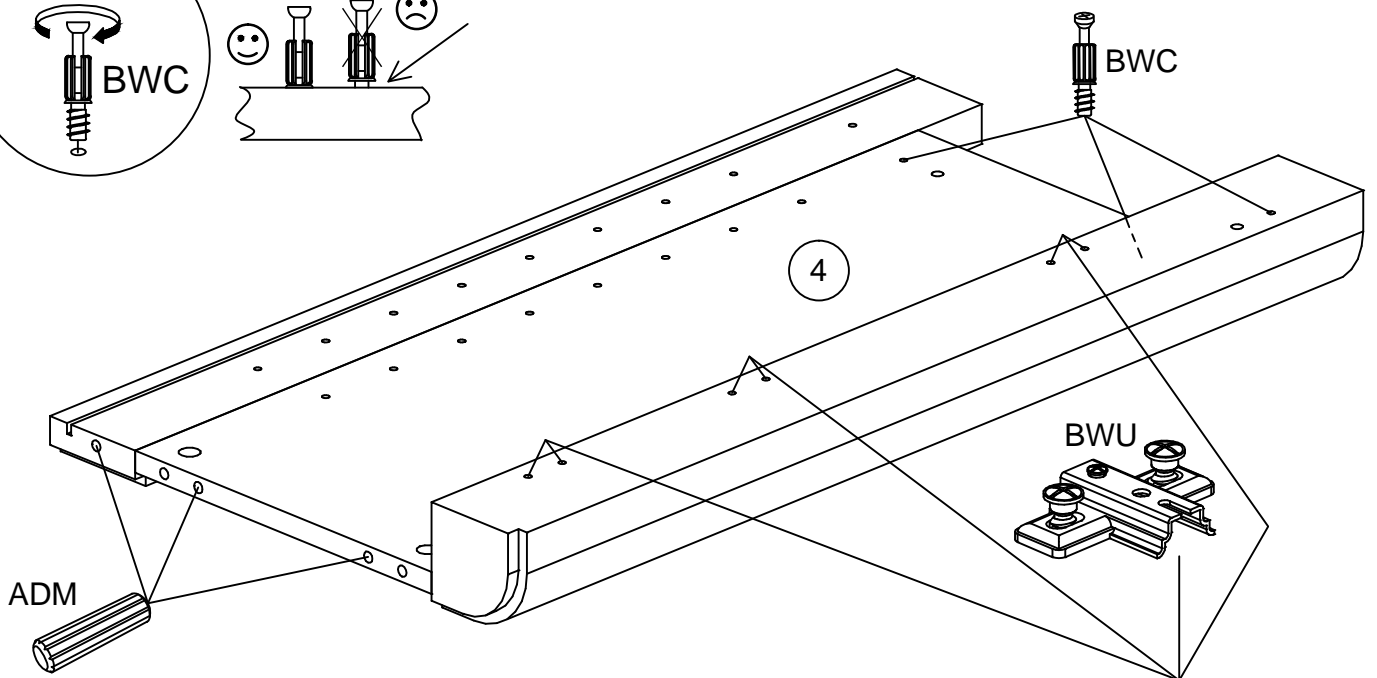
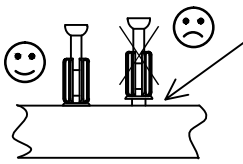
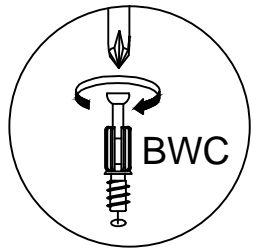



5



Ai x 2

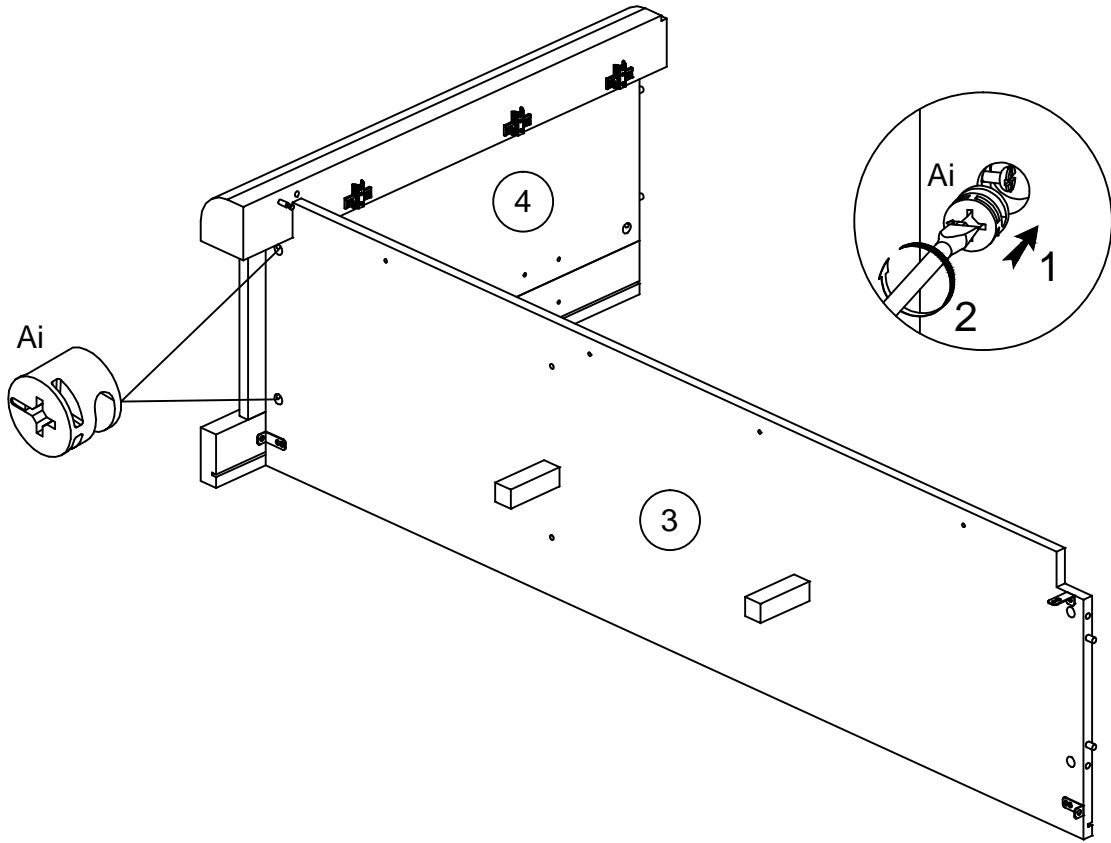

6



VB x 2

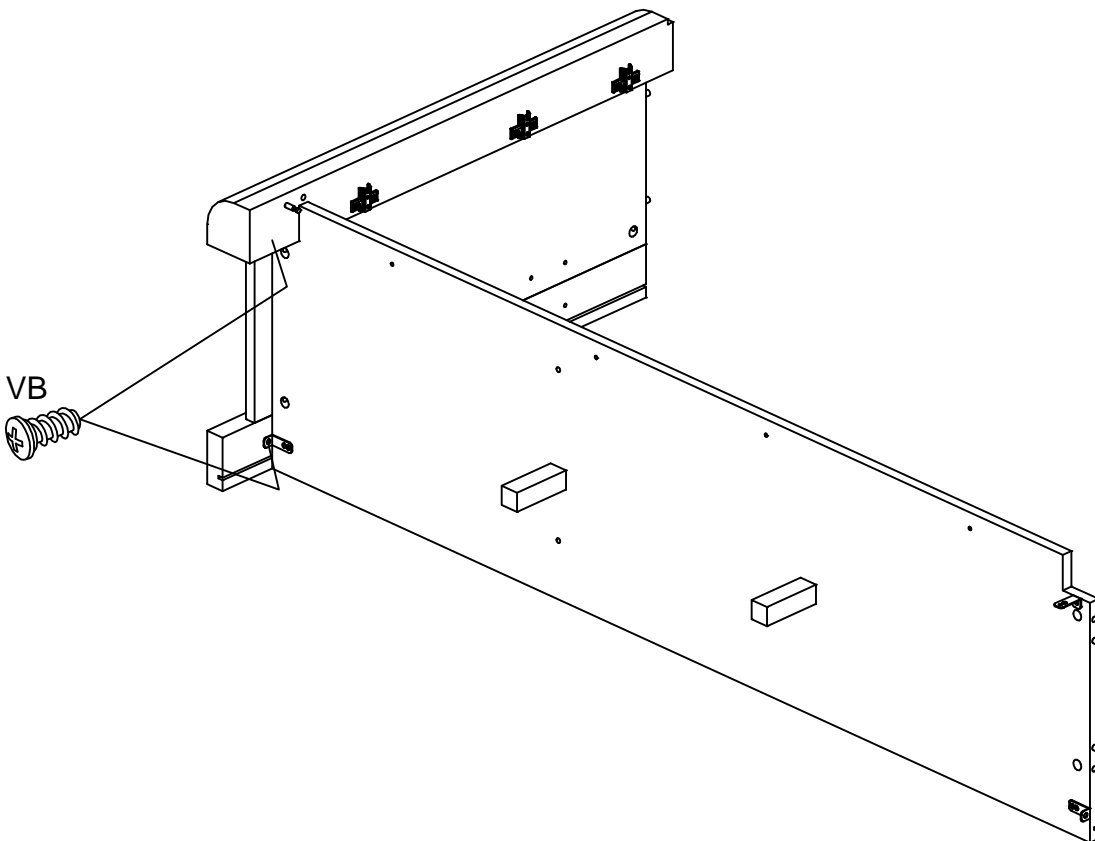

7

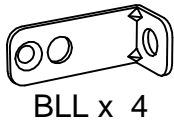

BLL x 4



VB x 4

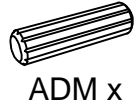

ADM x 2



Ai x 2

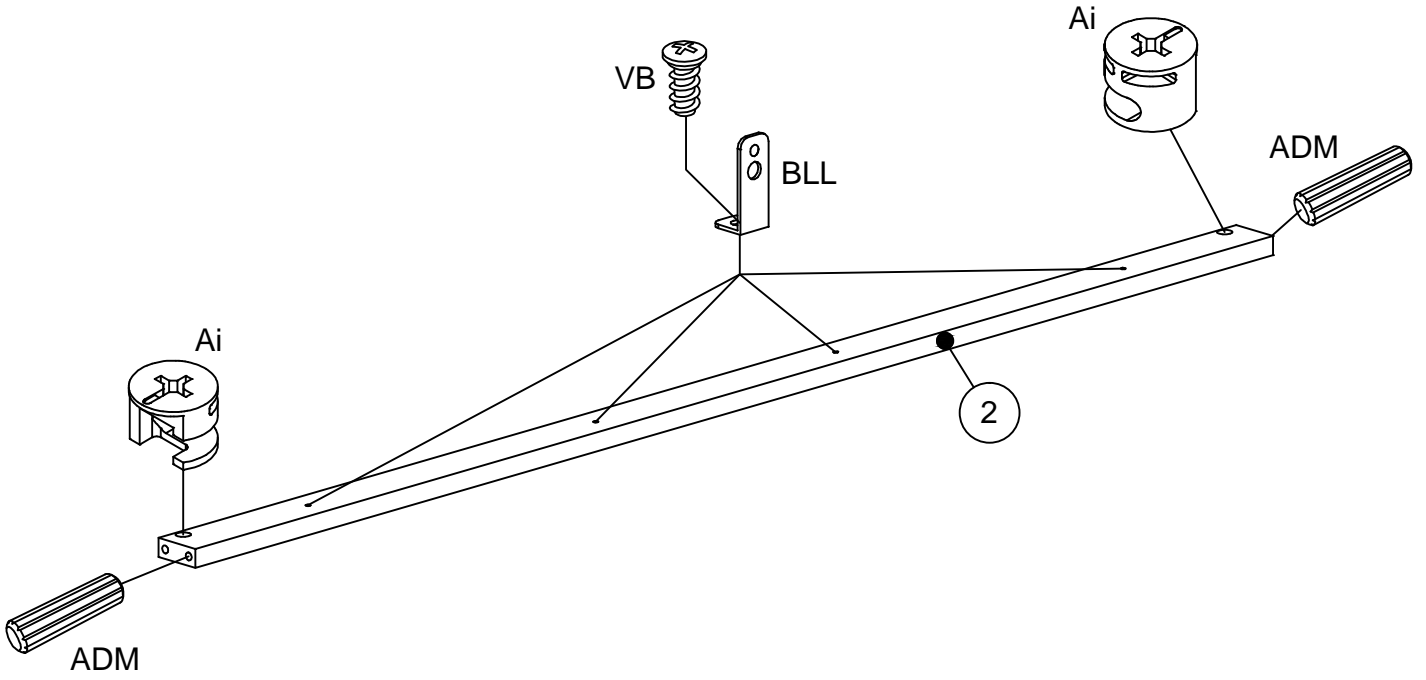

8



VB x 4

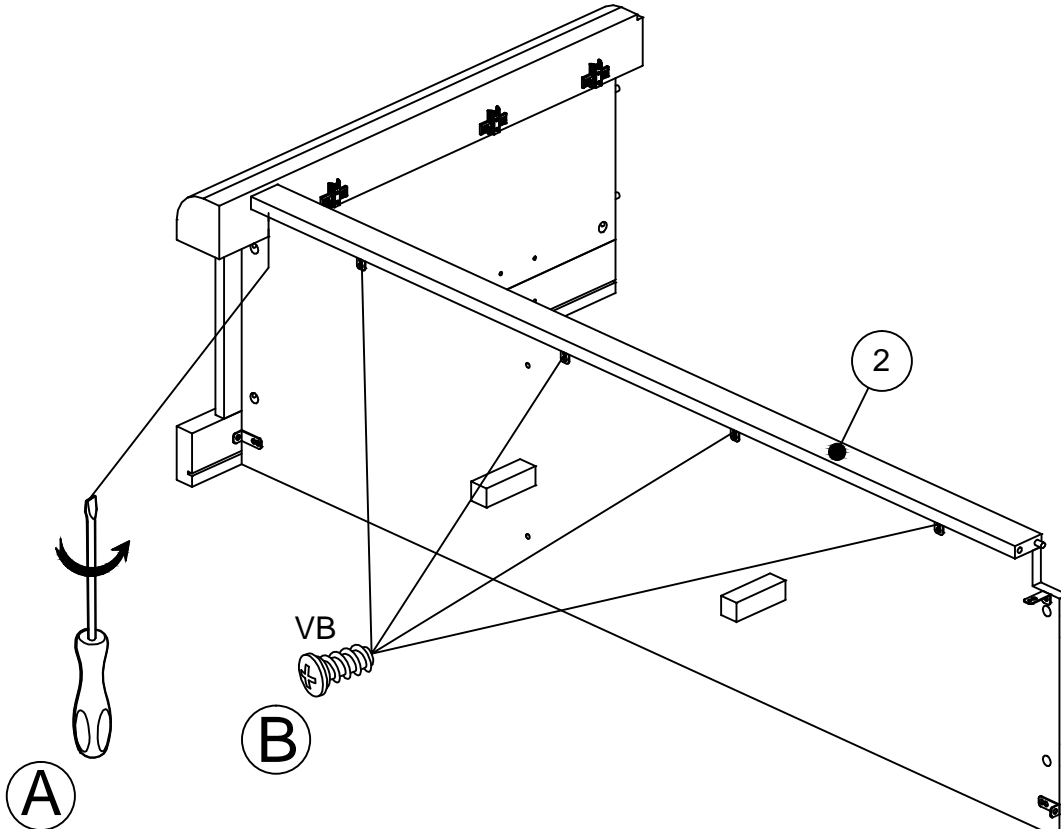

9



ADM x 4

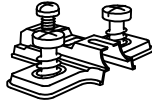

BWU x 2

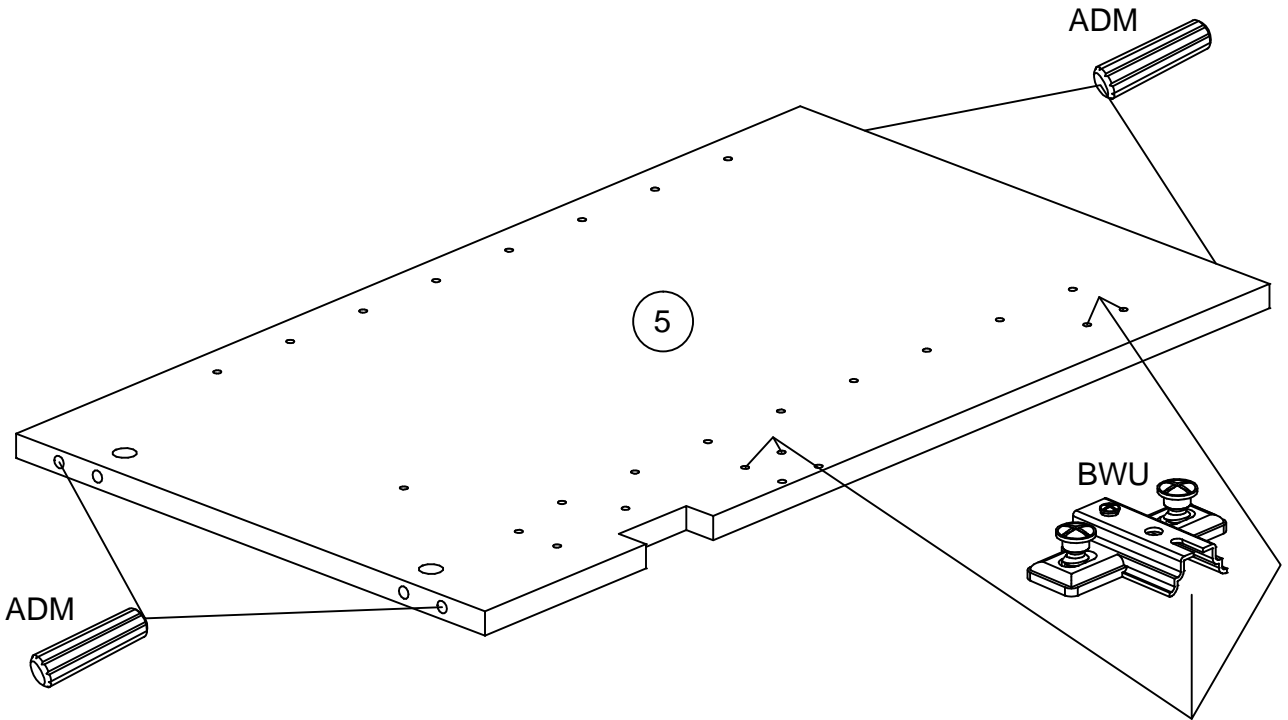

10

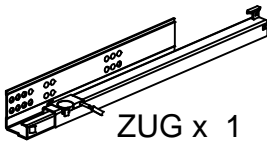

ZUG x 1



BWF x 3

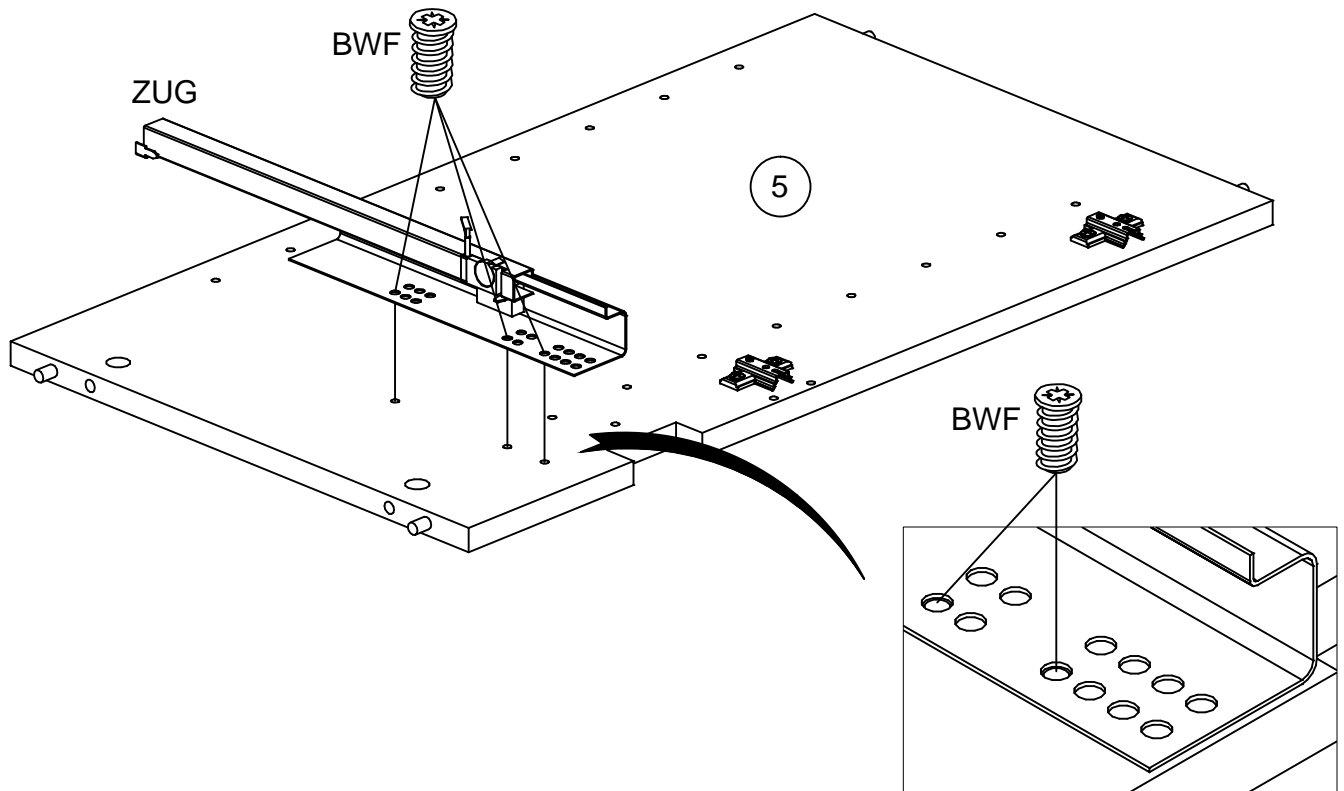

11

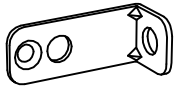

BLL x 1



VB x 1

1216C

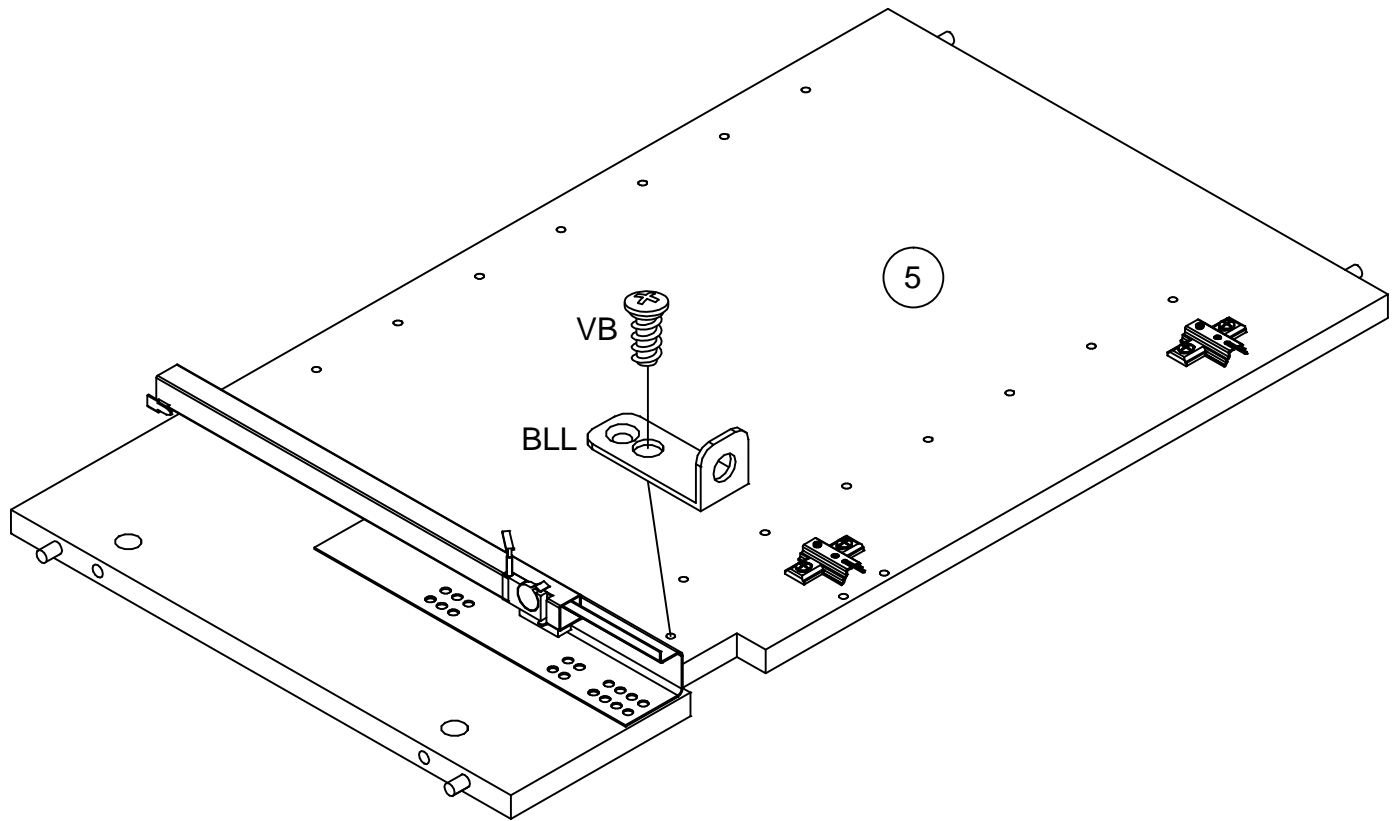

12

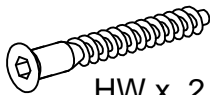

HW x 2



HV

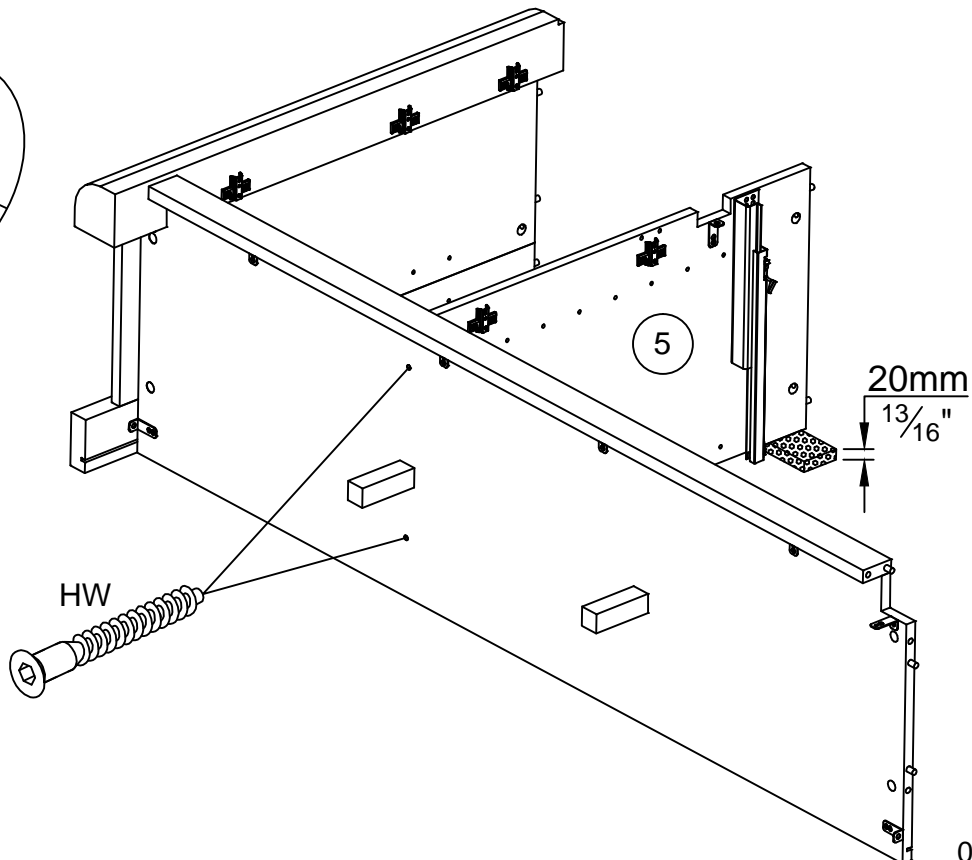
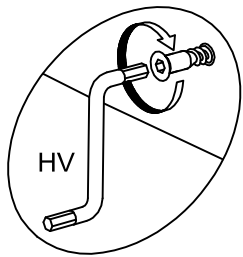

13



1216C

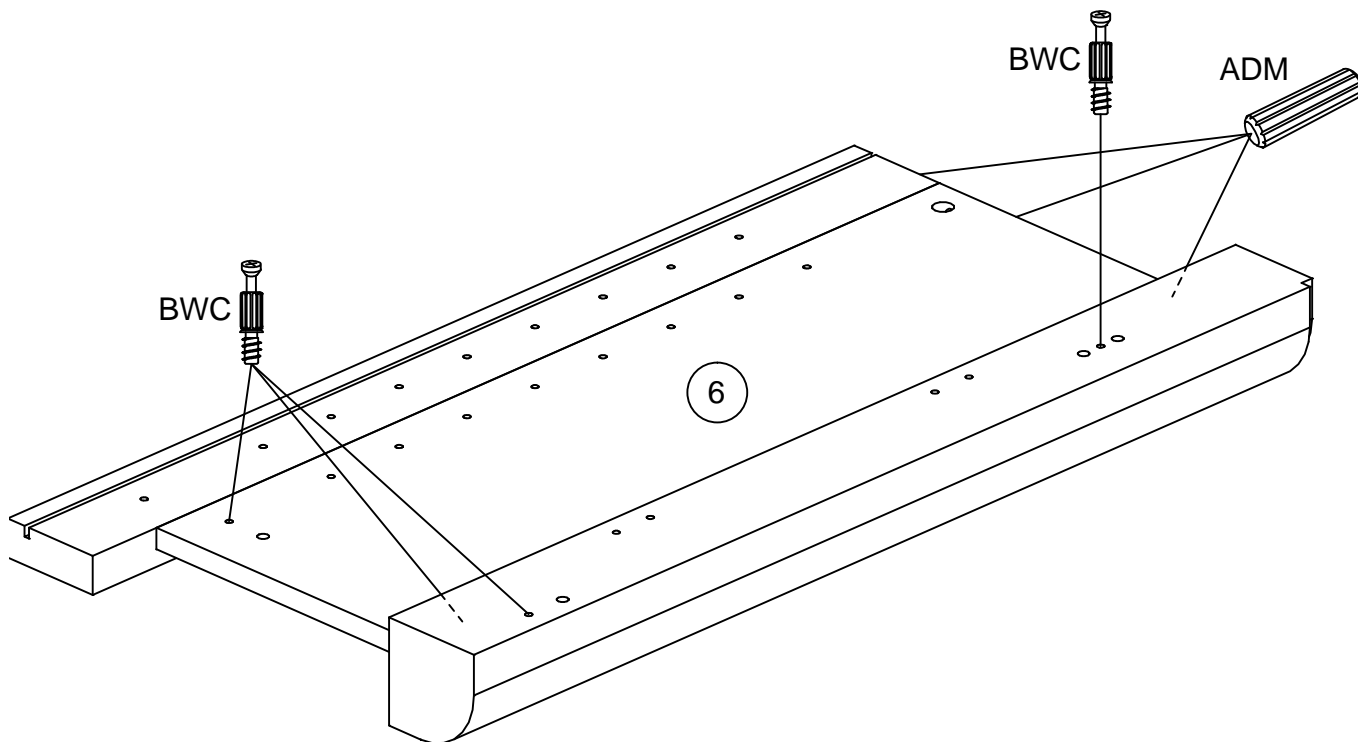

14

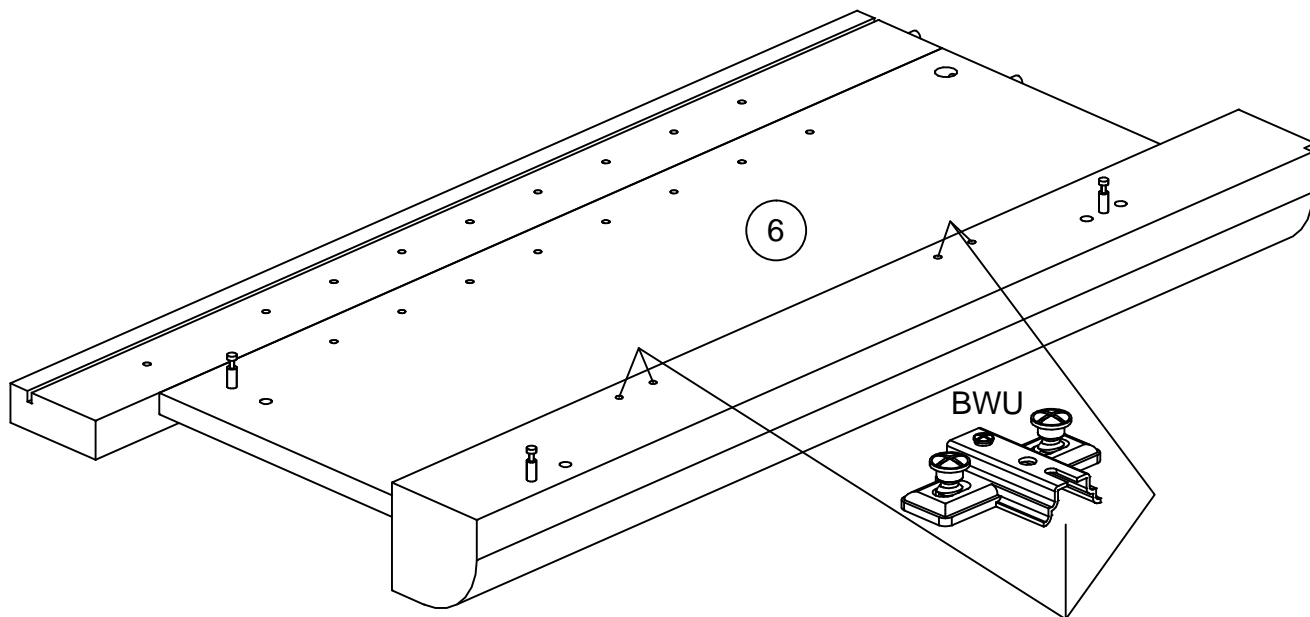
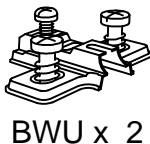

15



Ai x 2

1216C

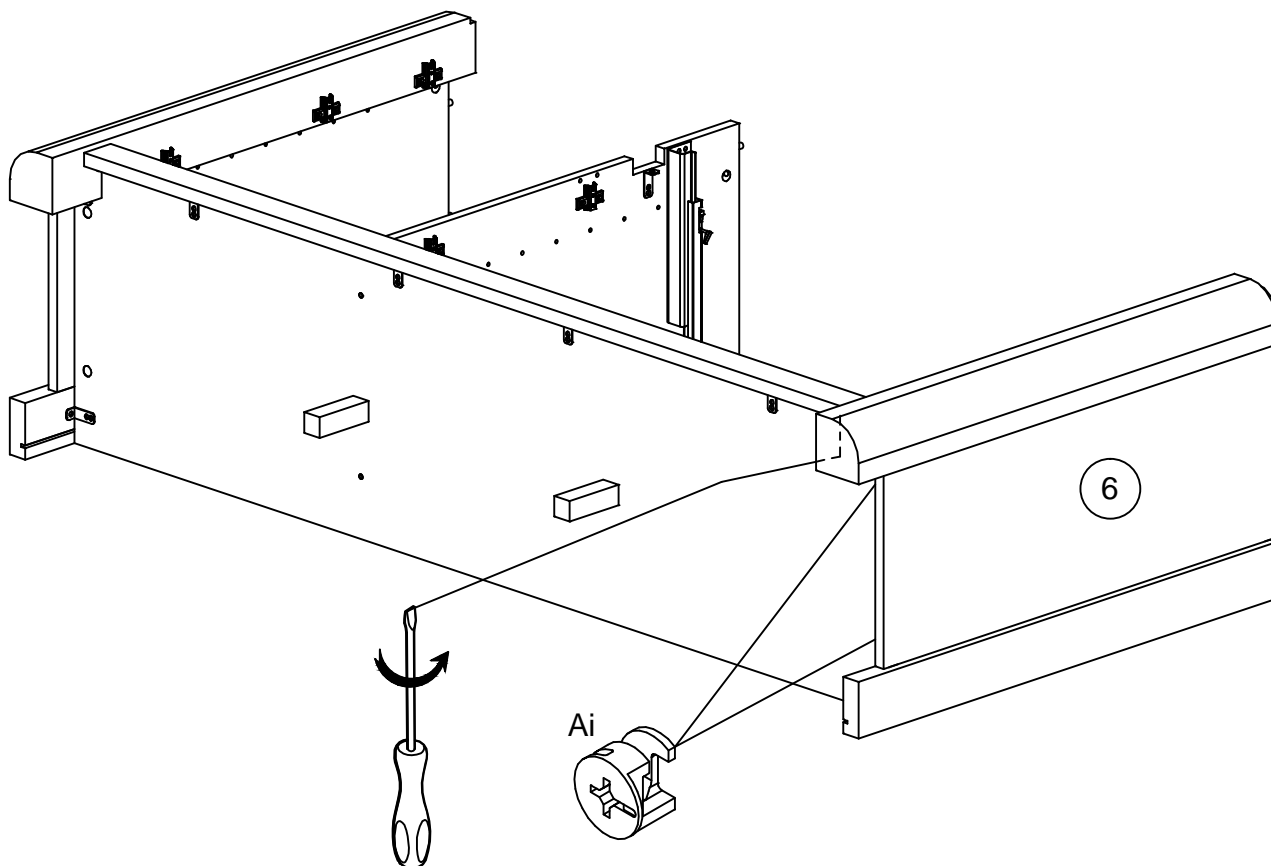

16



VB x 2

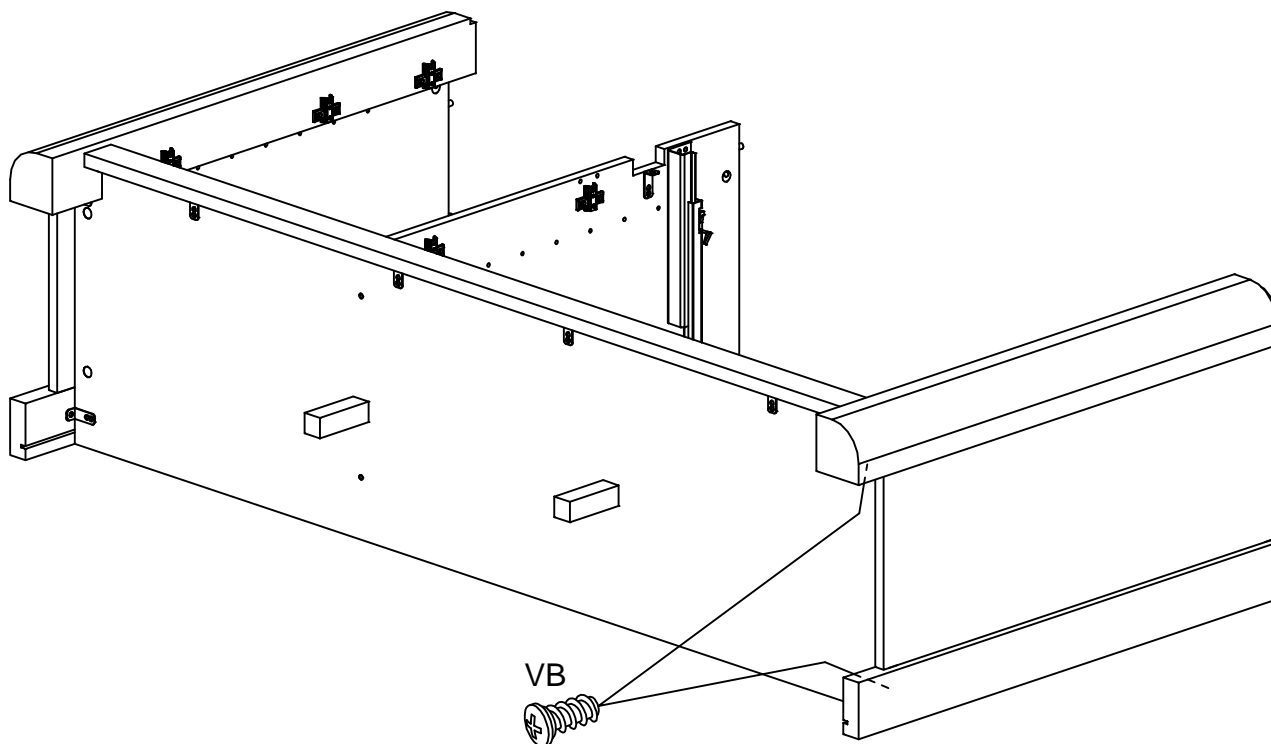

17



ADM x 2



Ai x 1

1216C

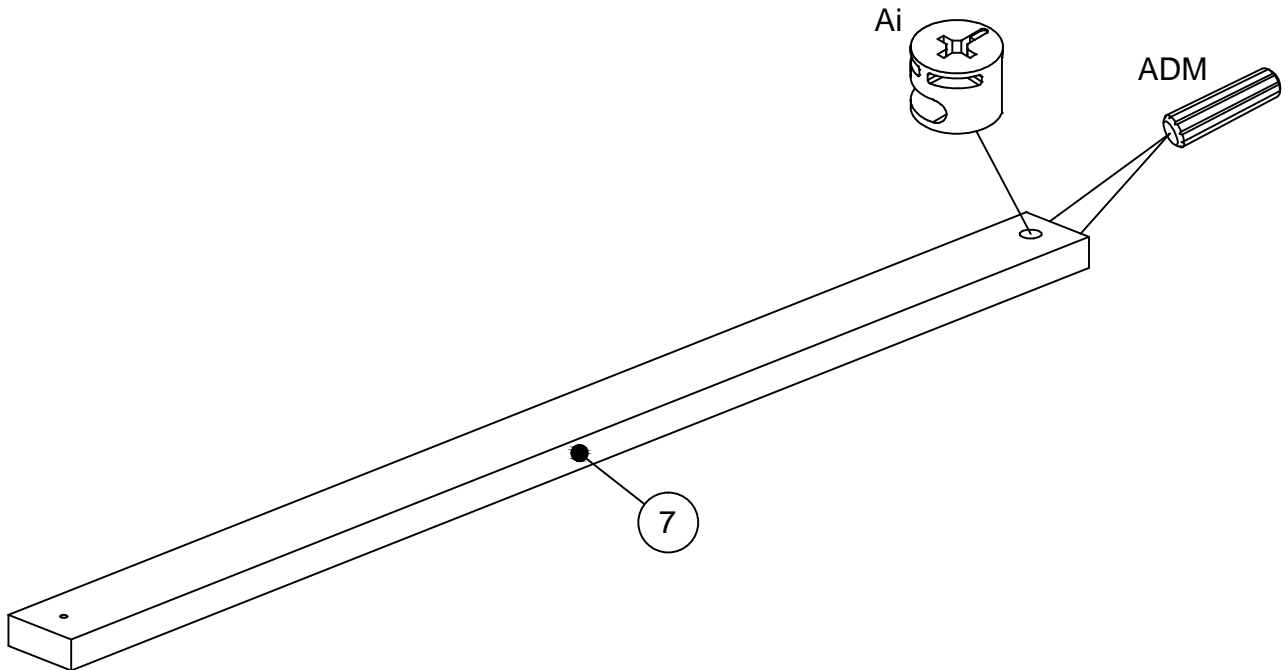

18



VB x 1

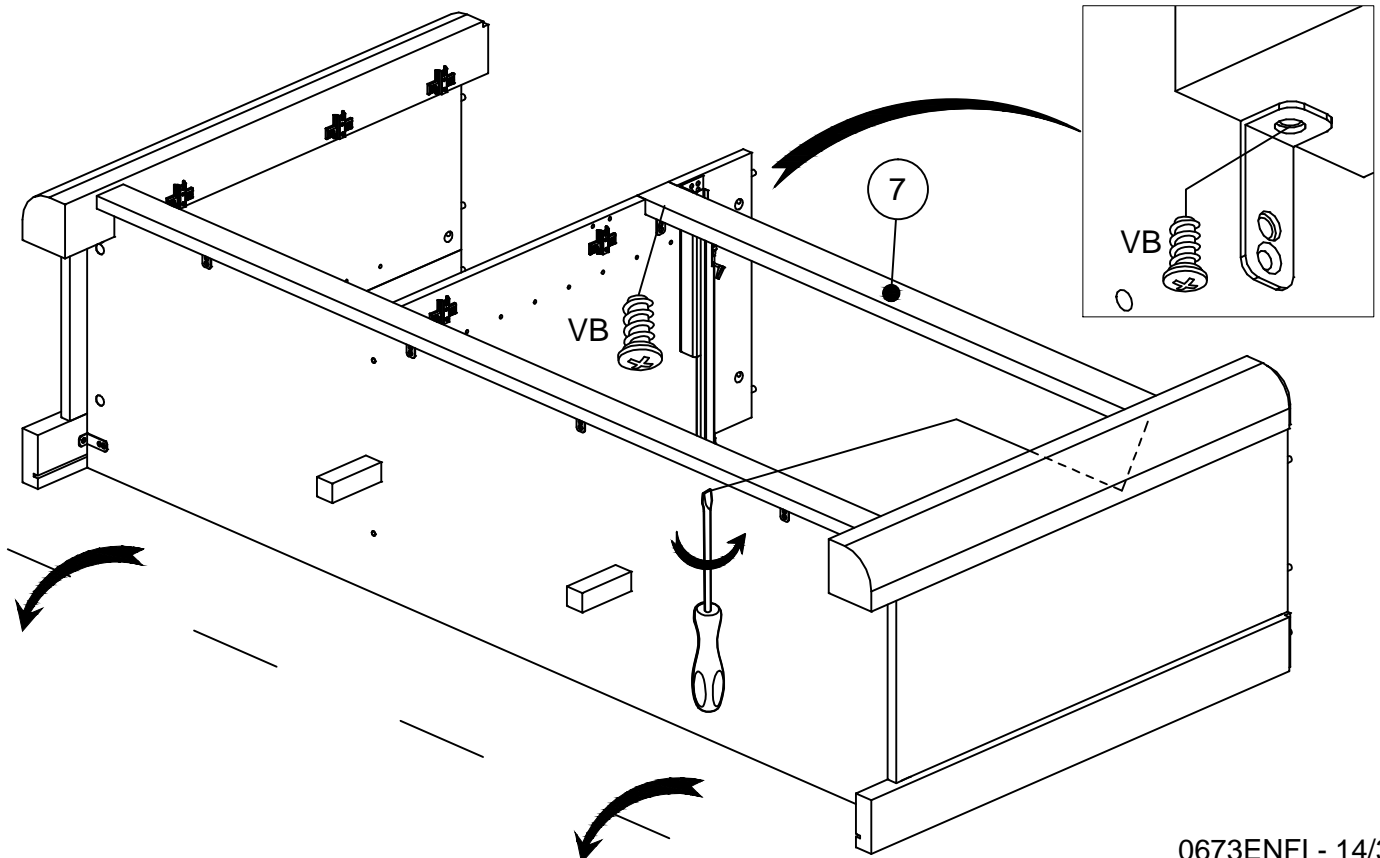

19

1216C

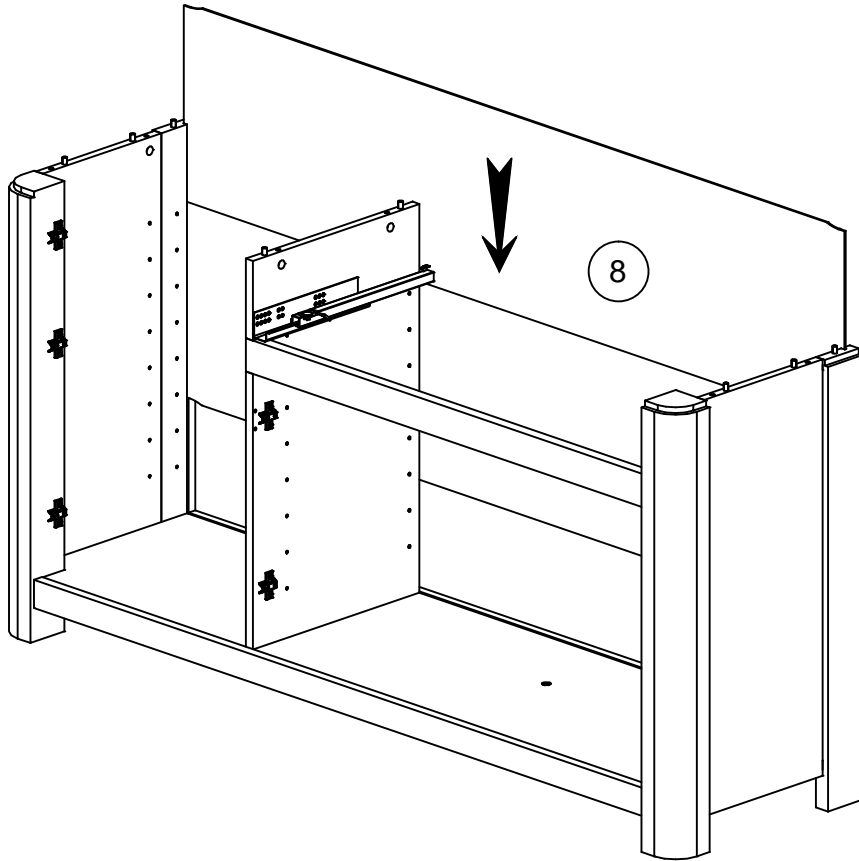

20

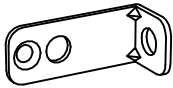

BLL x 3



VB x 3



BWC x 6

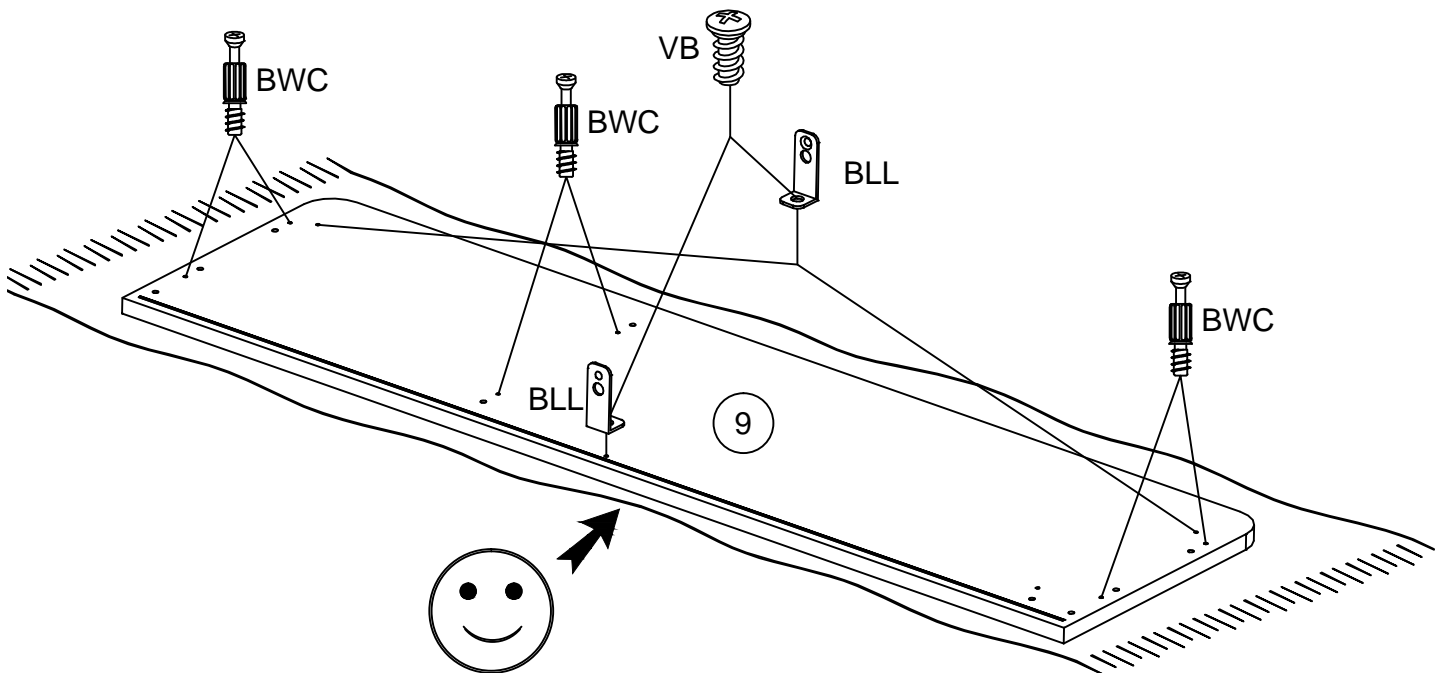



21



Ai x 6

1216C

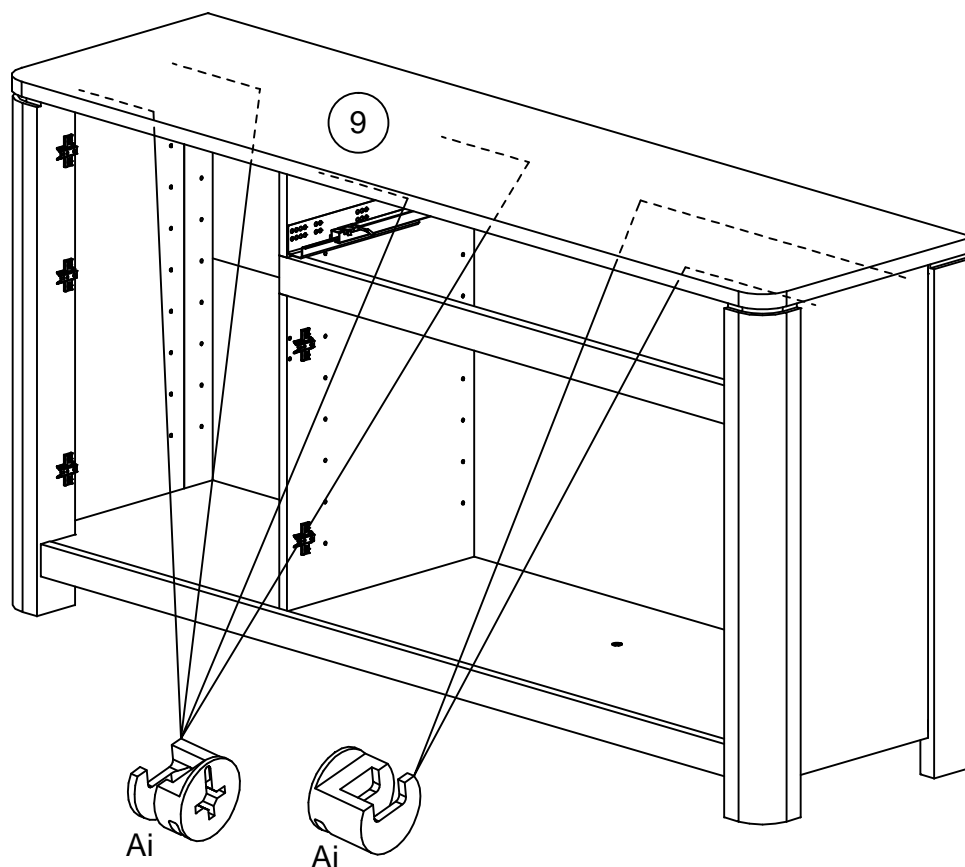

22



VB x 2

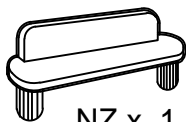

NZ x 1



AQO x 1

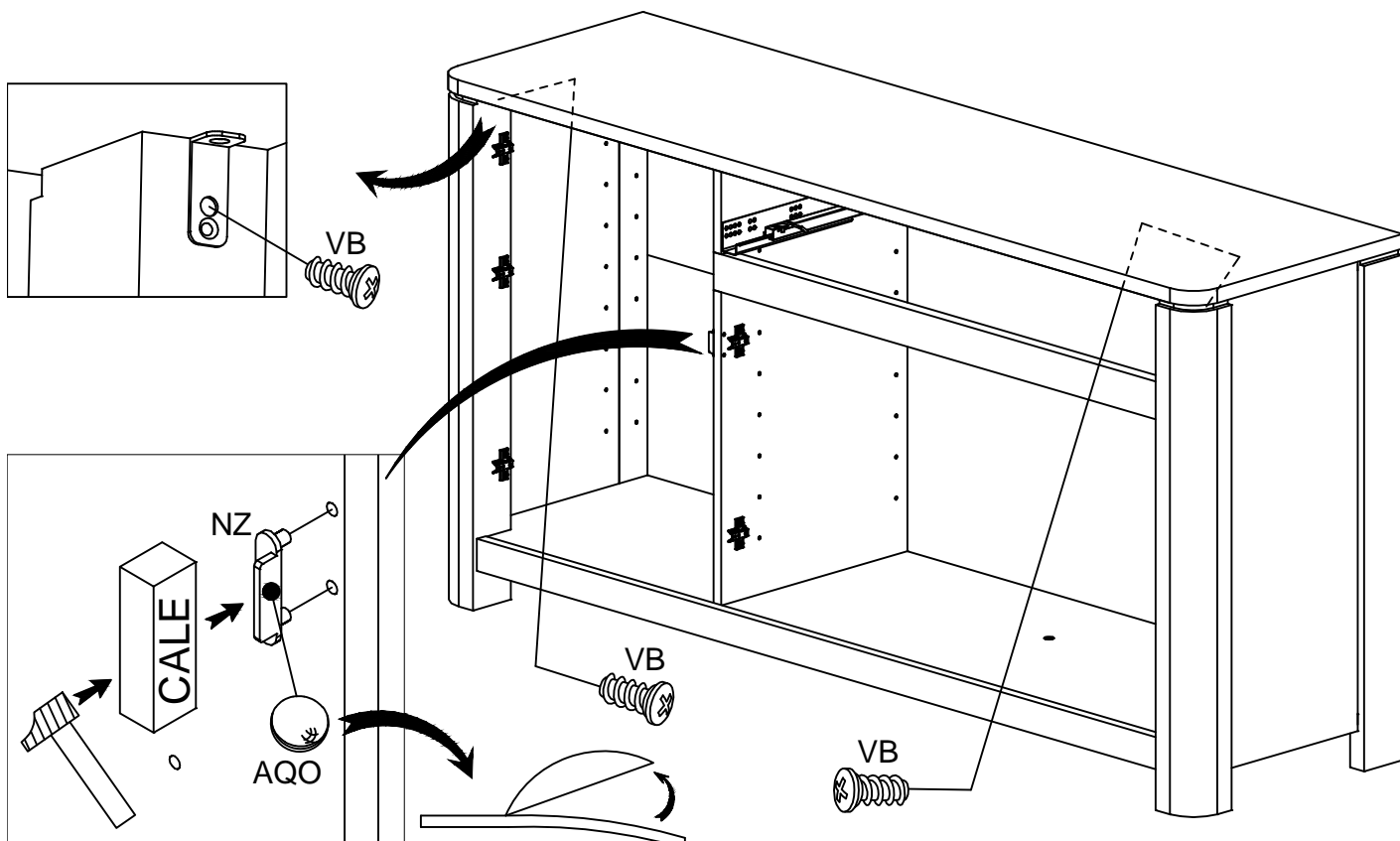

23



ADM x 1

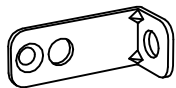

BLL x 1



VB x 1

1216C

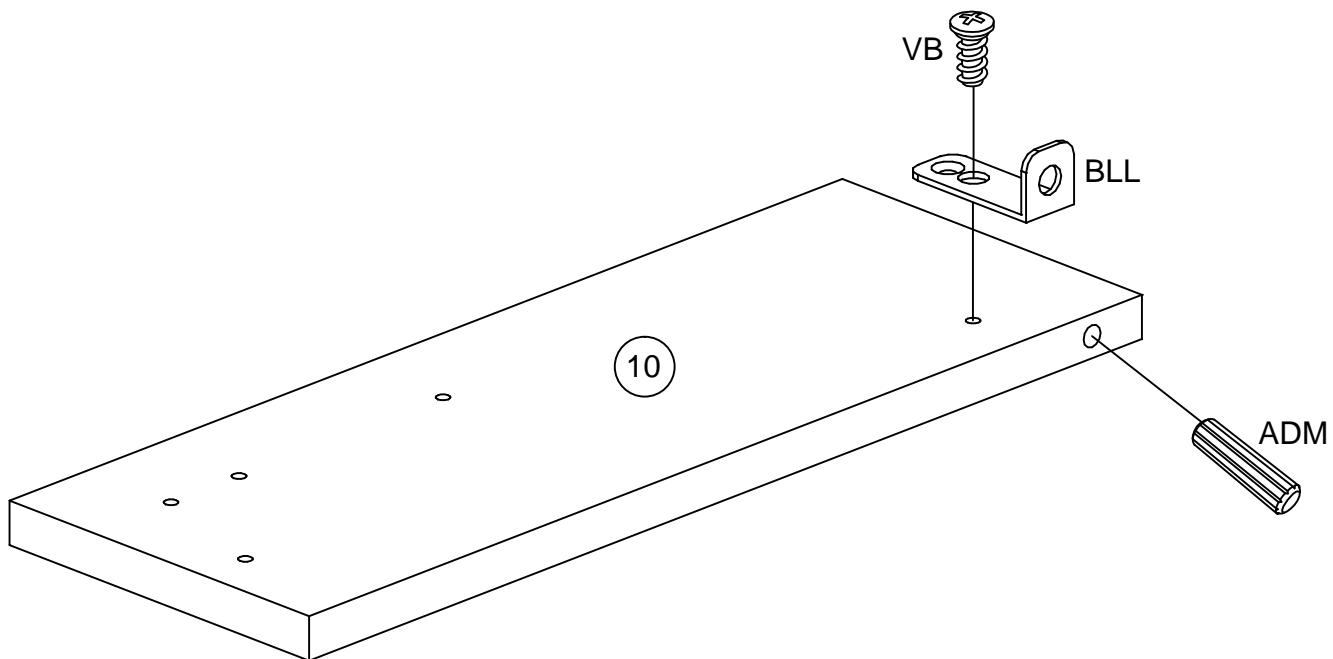

24

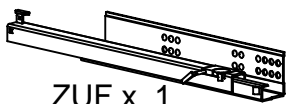

ZUF x 1



BWF x 3

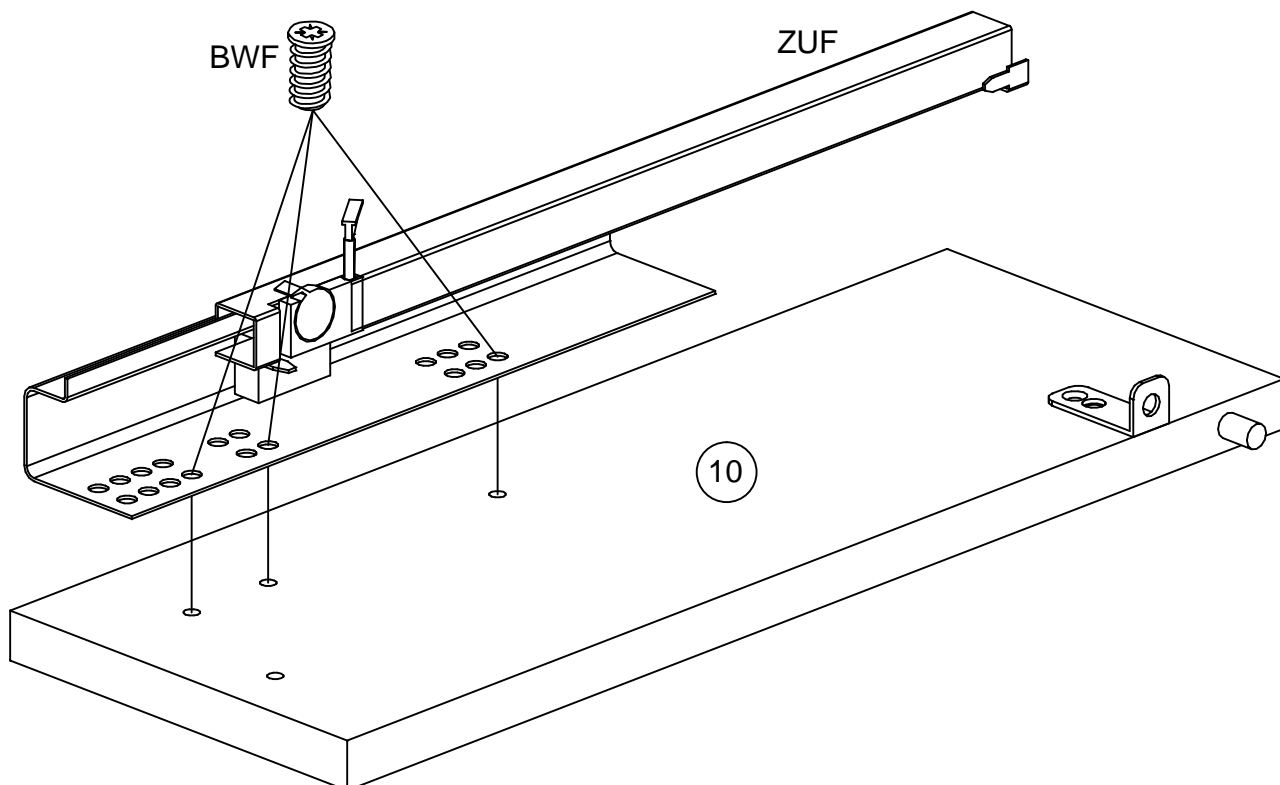

25

VB x 1



WE x 1

1216C

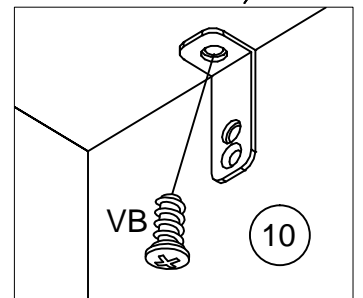
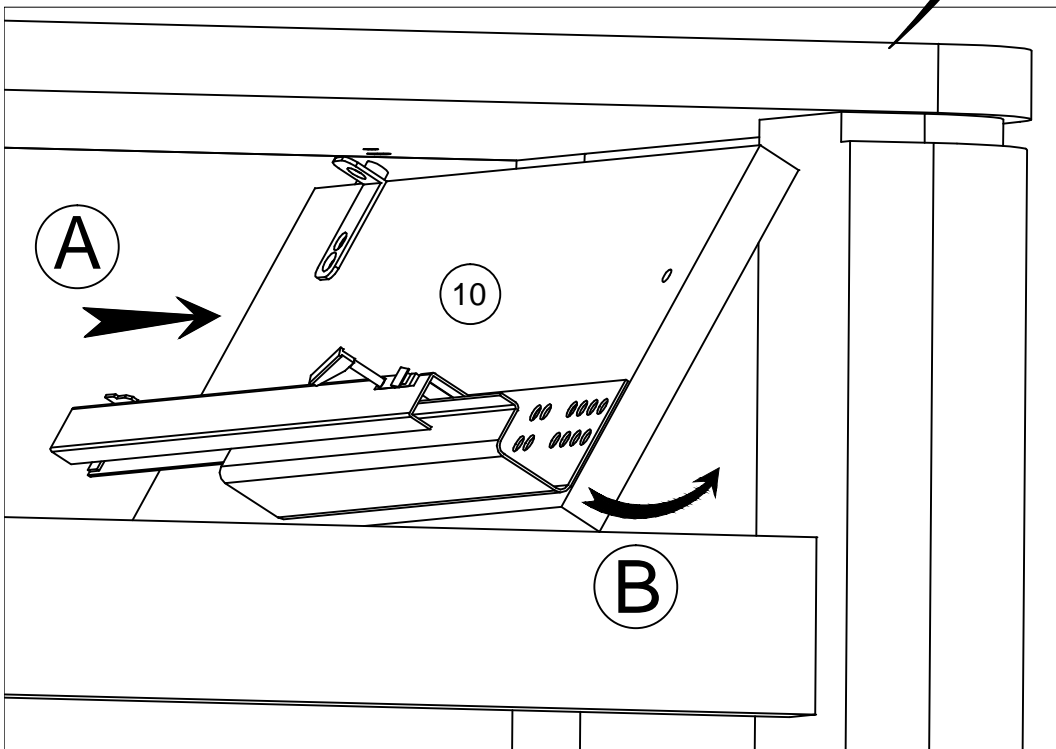
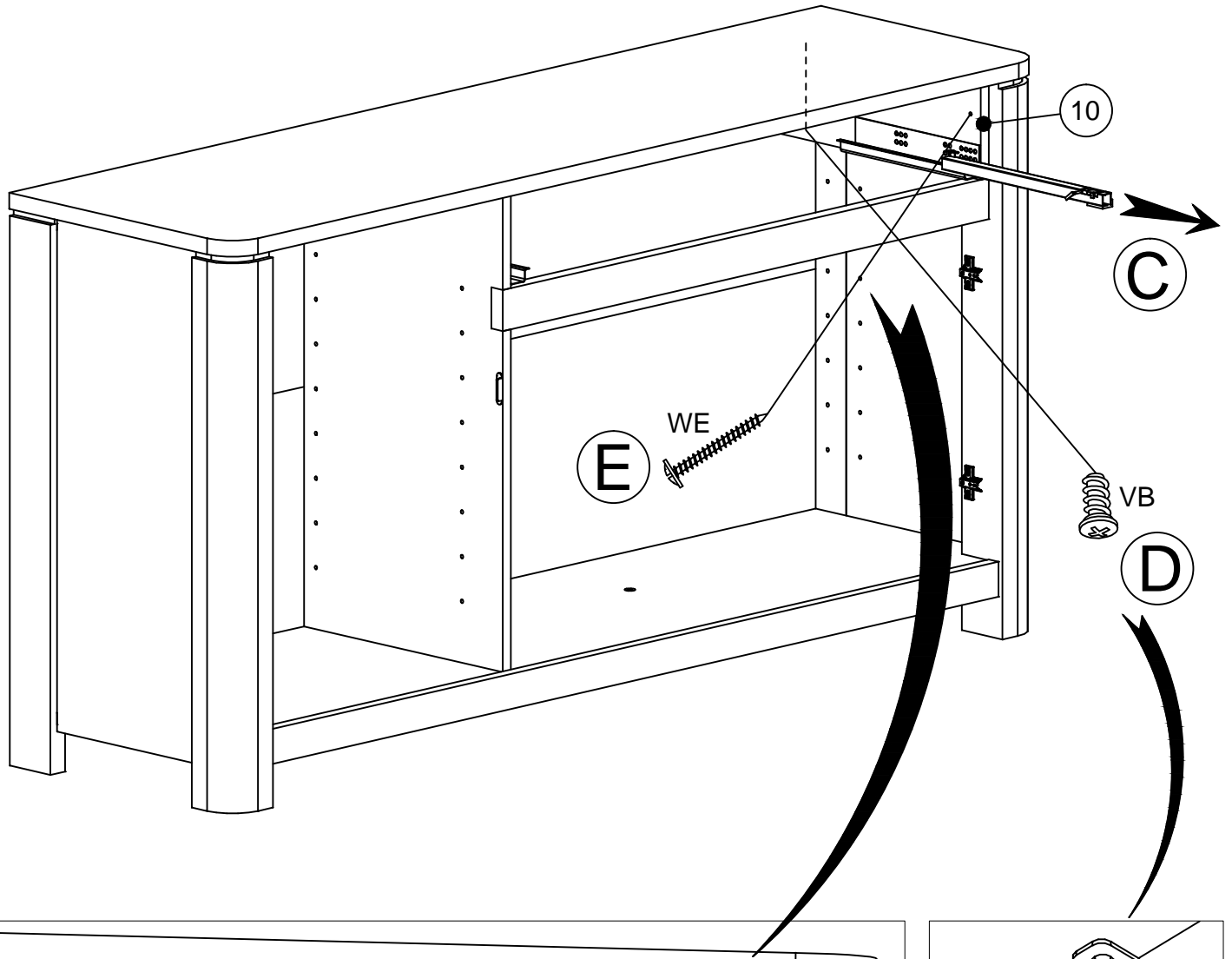

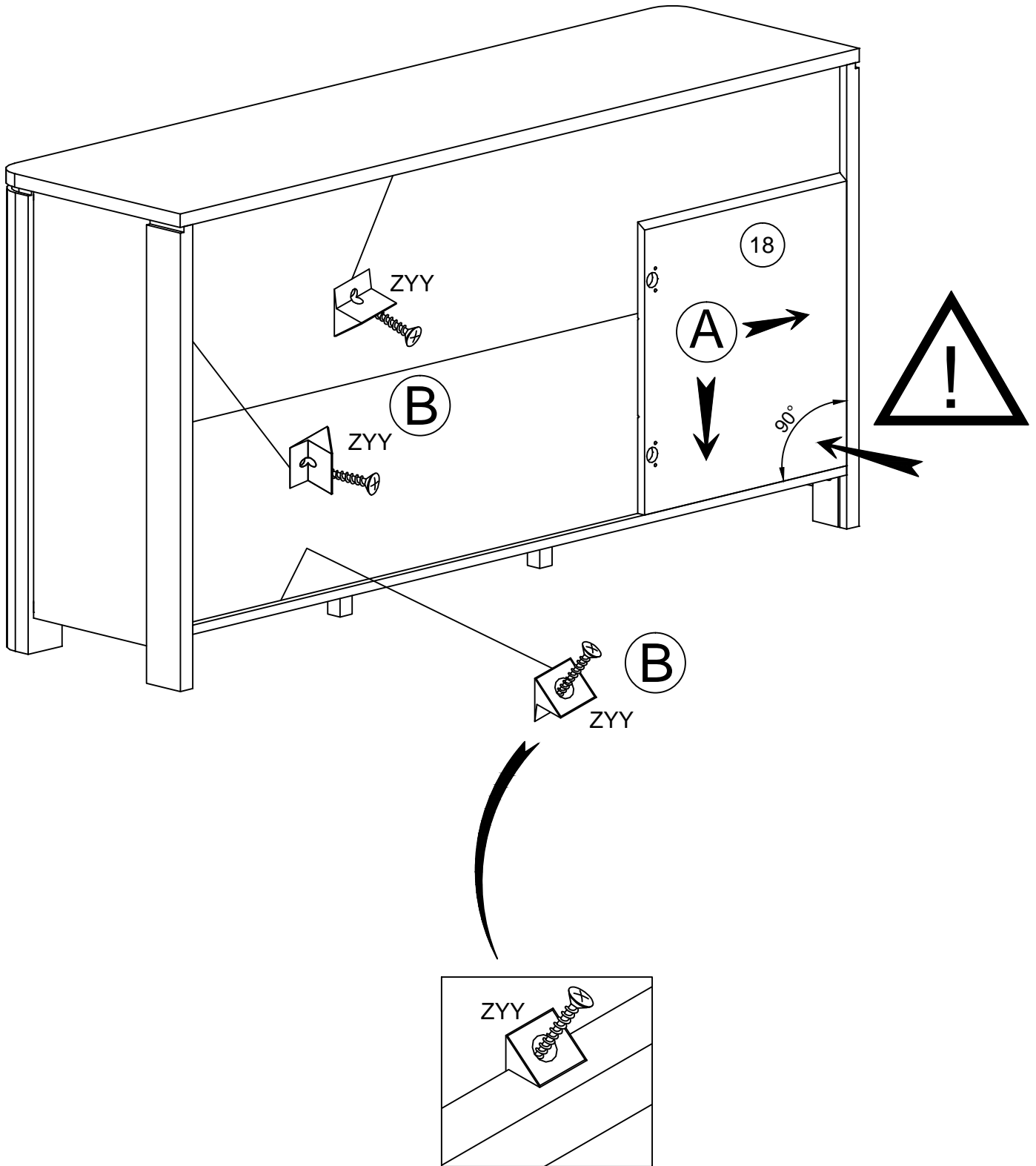
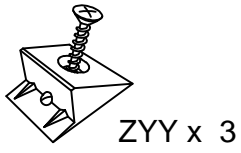

27

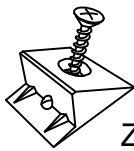

ZYY x 2



XG x 2

1216C

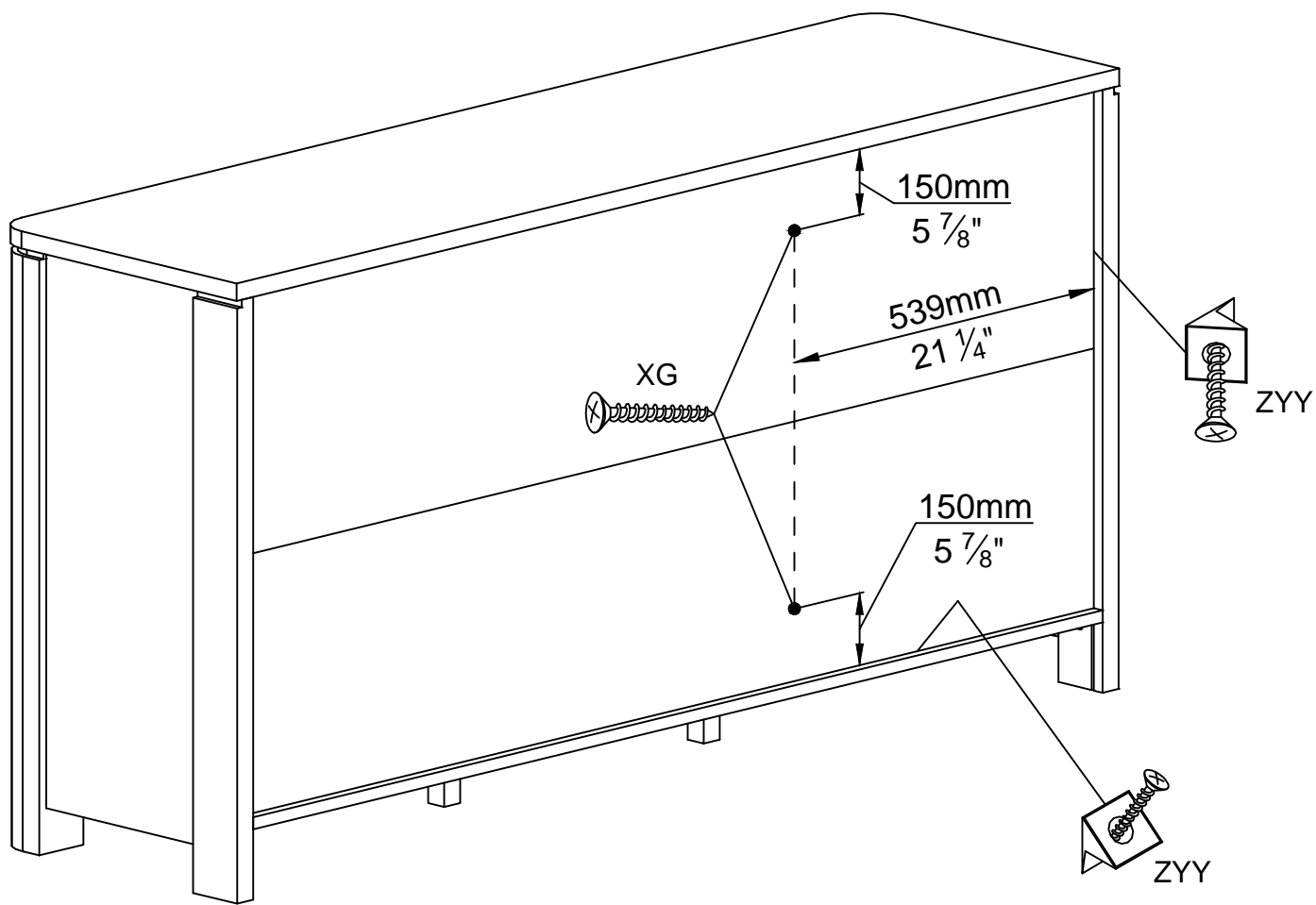

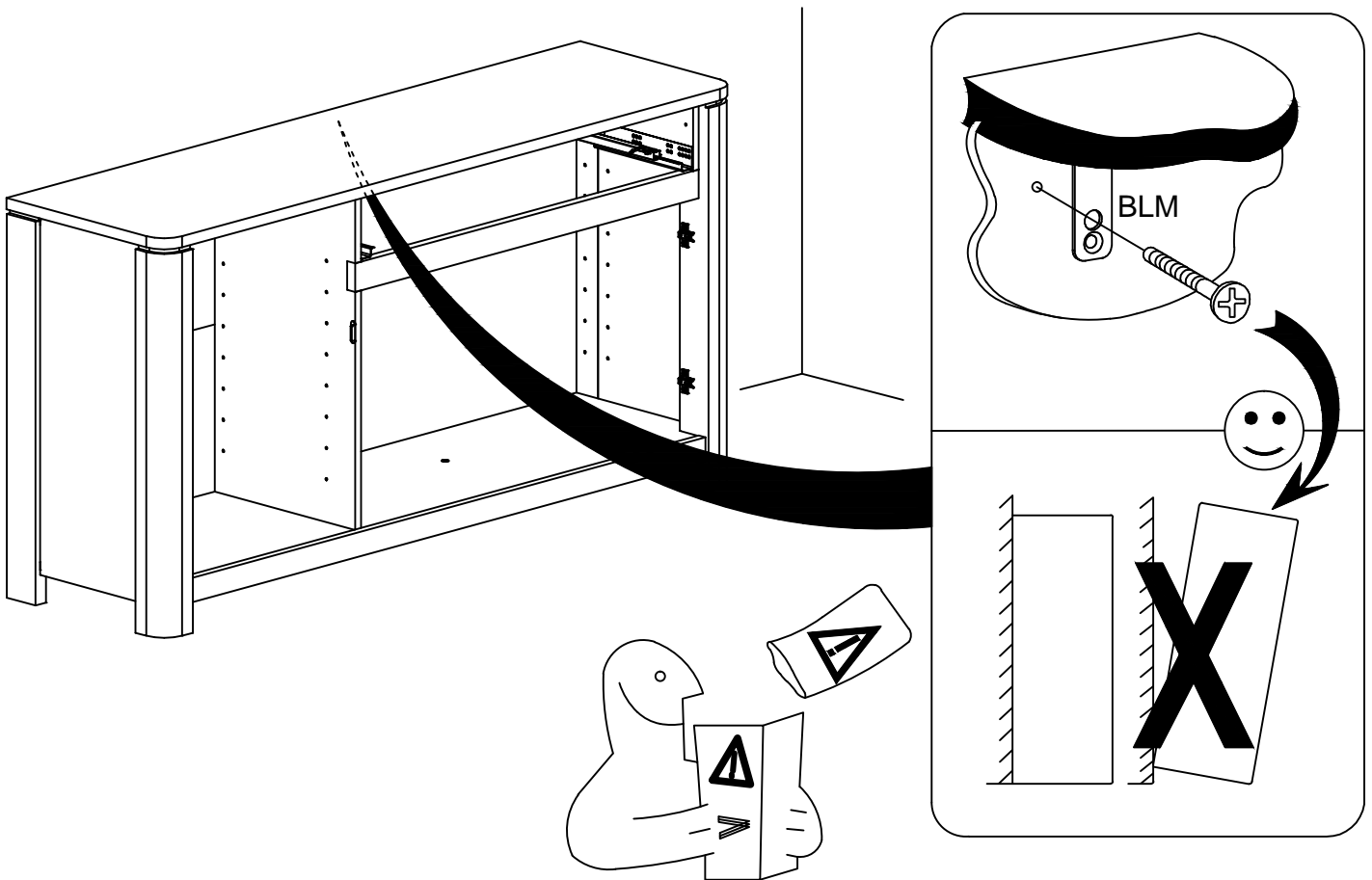
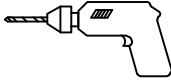

- (FR) Pour votre sécurité: Fixation du meuble au mur. Attention, la fixation doit être réalisée par une personne compétente car cela nécessite des chevilles adaptées à la nature de votre mur.
- (GB) For your own safety: Attach the furniture to the wall. Important: The furniture must be attached by a qualified person using dowels that are suited to the type of wall.
- (D) Für ihre Sicherheit: Befestigung des Möbelstücks an der Wand. Achtung, die Befestigung muss von einem Fachmann vorgenommen werden, weil sie an die Wand angepasste Dübel erfordert.
- (E) Para su seguridad: Fijación del meuble a la pared. Ojo! La fijación deberá llevarla a cabo una persona competente ya que necesitará unos tacos adaptados a tipo de pared.
- (PT) Para a sua segurança: Fixação do móvel na parede. Atenção, a fixação deve ser efectuada por uma pessoa competente, pois exige a utilização de cavilhas adaptadas à natureza da parede.
- (I) Per la vostra sicurezza: Fissaggio del mobile alla parete. Nota bene, il fissaggio deve essere eseguito da personale specializzato, poiché l'utilizzo di tasselli adattati alla parete.
- (NL) Voor uw veiligheid: Bevestiging van het meubel aan de muur. Let op, de bevestiging moet worden uitgevoerd door een bevoegd persoon, want hiervoor zijn pluggen nodig die specifiek geschikt zijn voor de betreffende muur.

29



BWD x 8

1216C

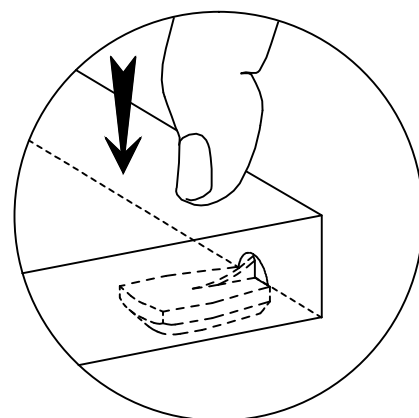
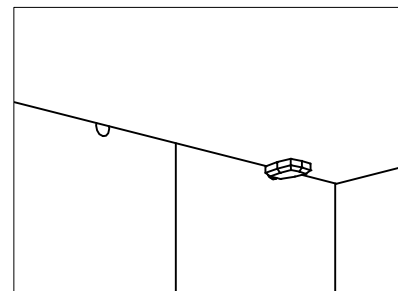
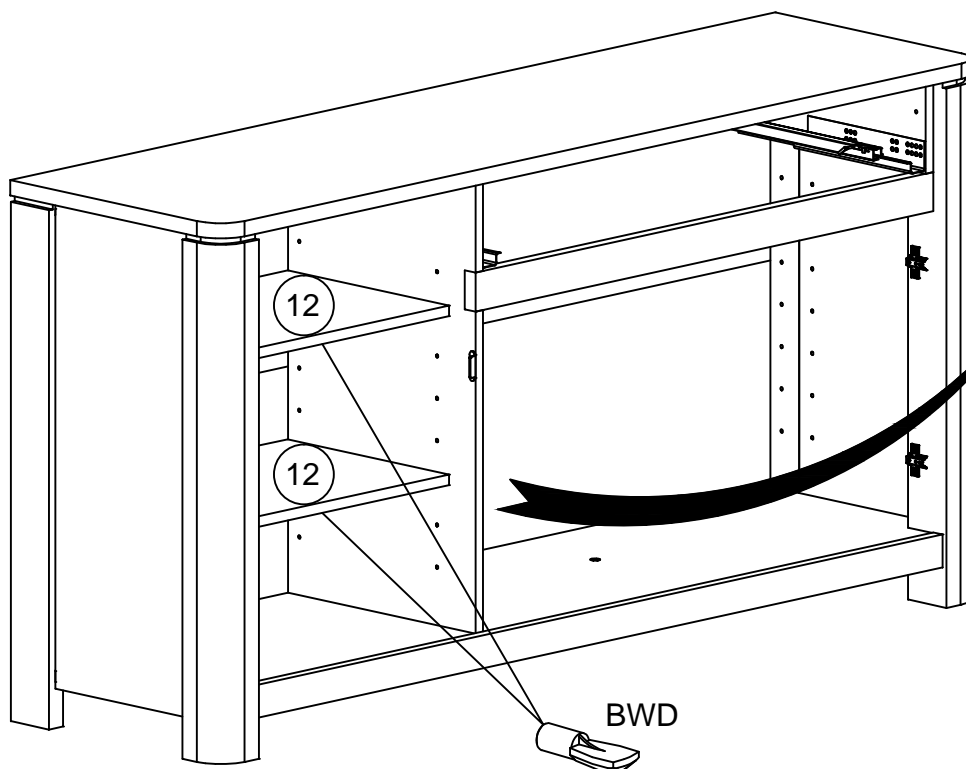

30



BWD x 4

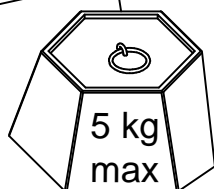
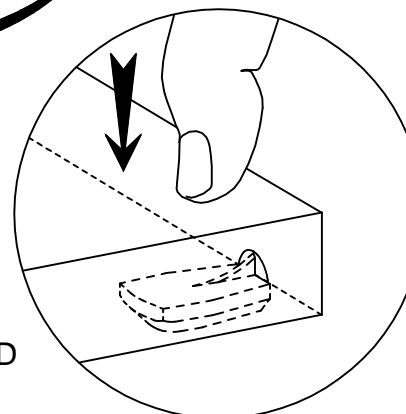
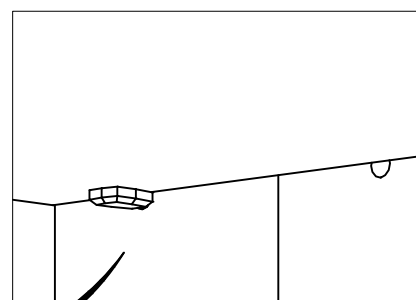
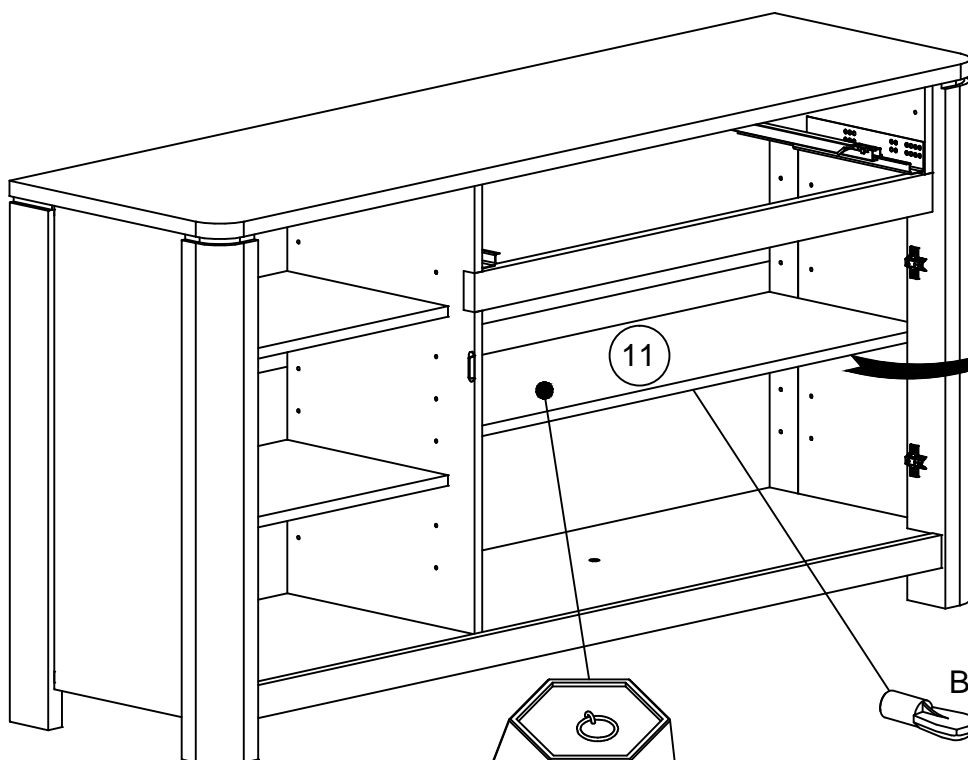

BWD

31

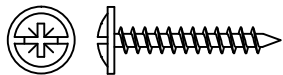

XN x 6

1216C

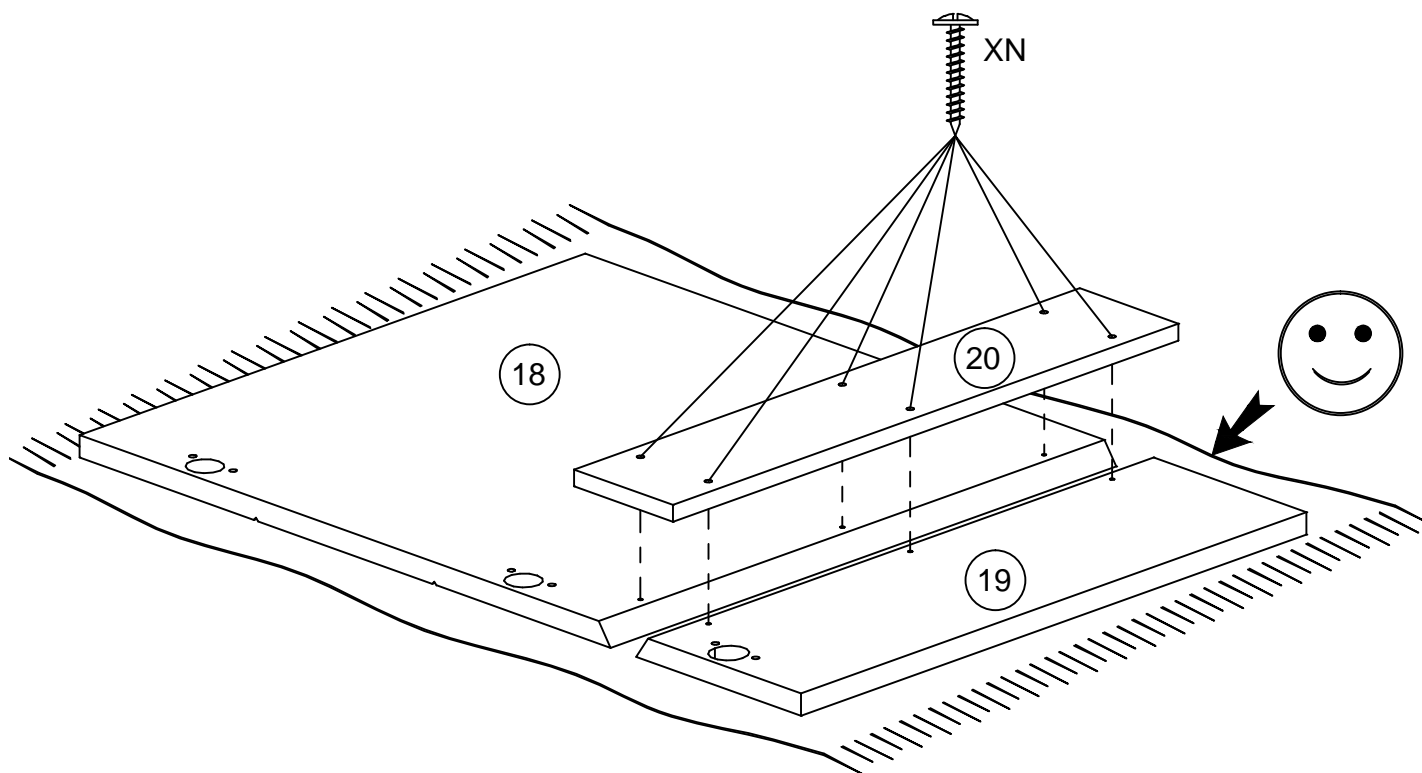

32

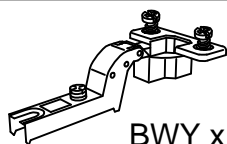

BWY x 3

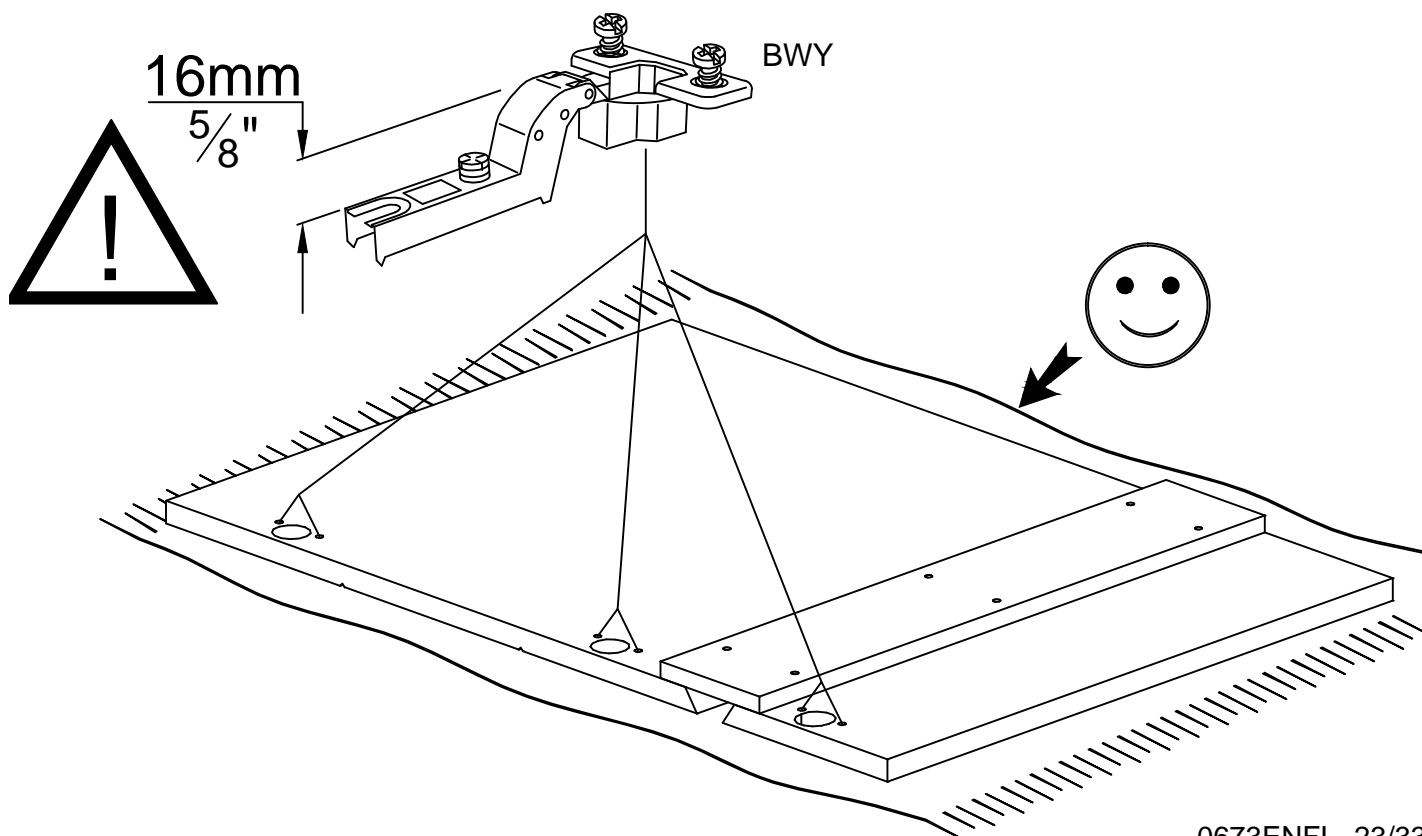



33

1216C

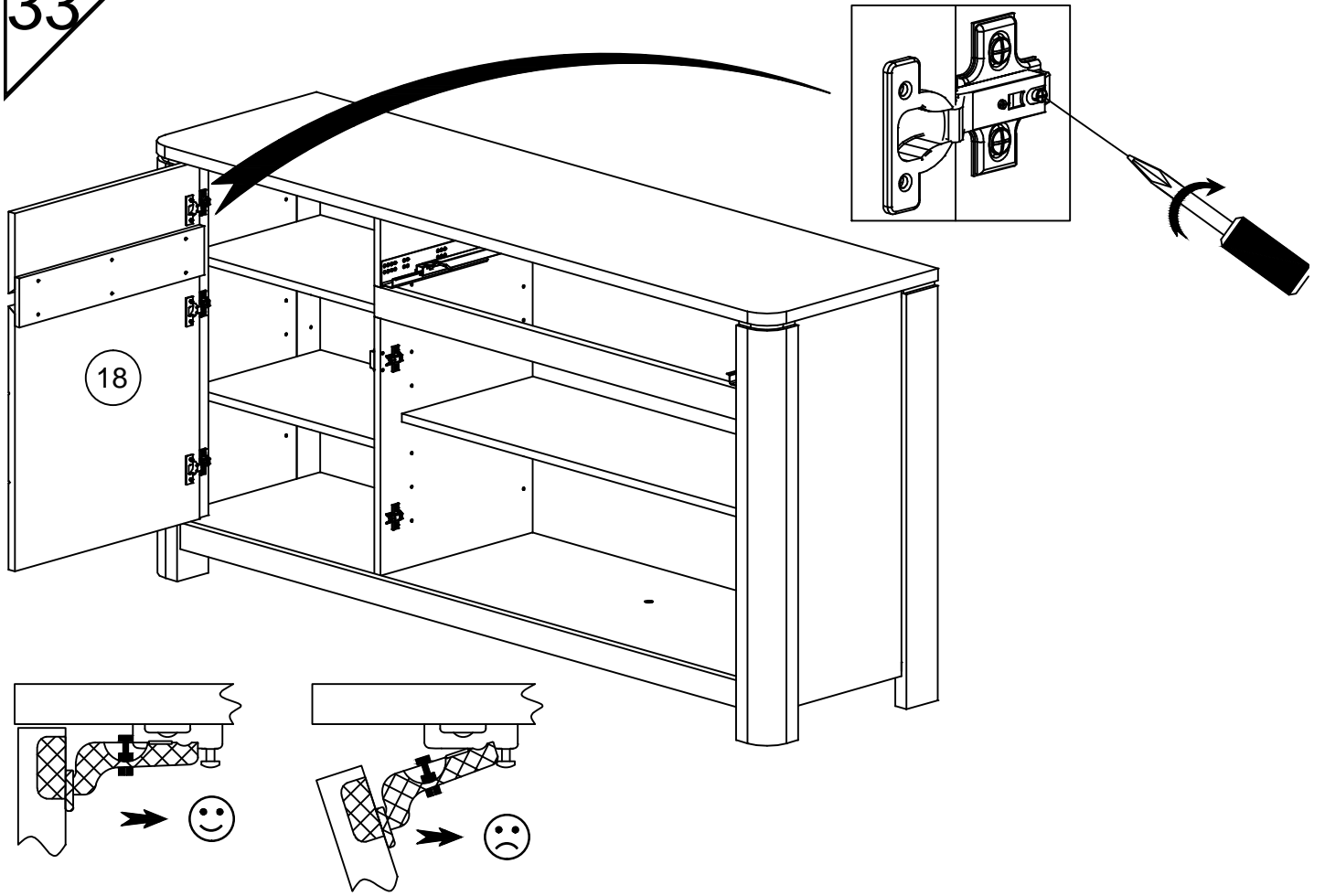

34

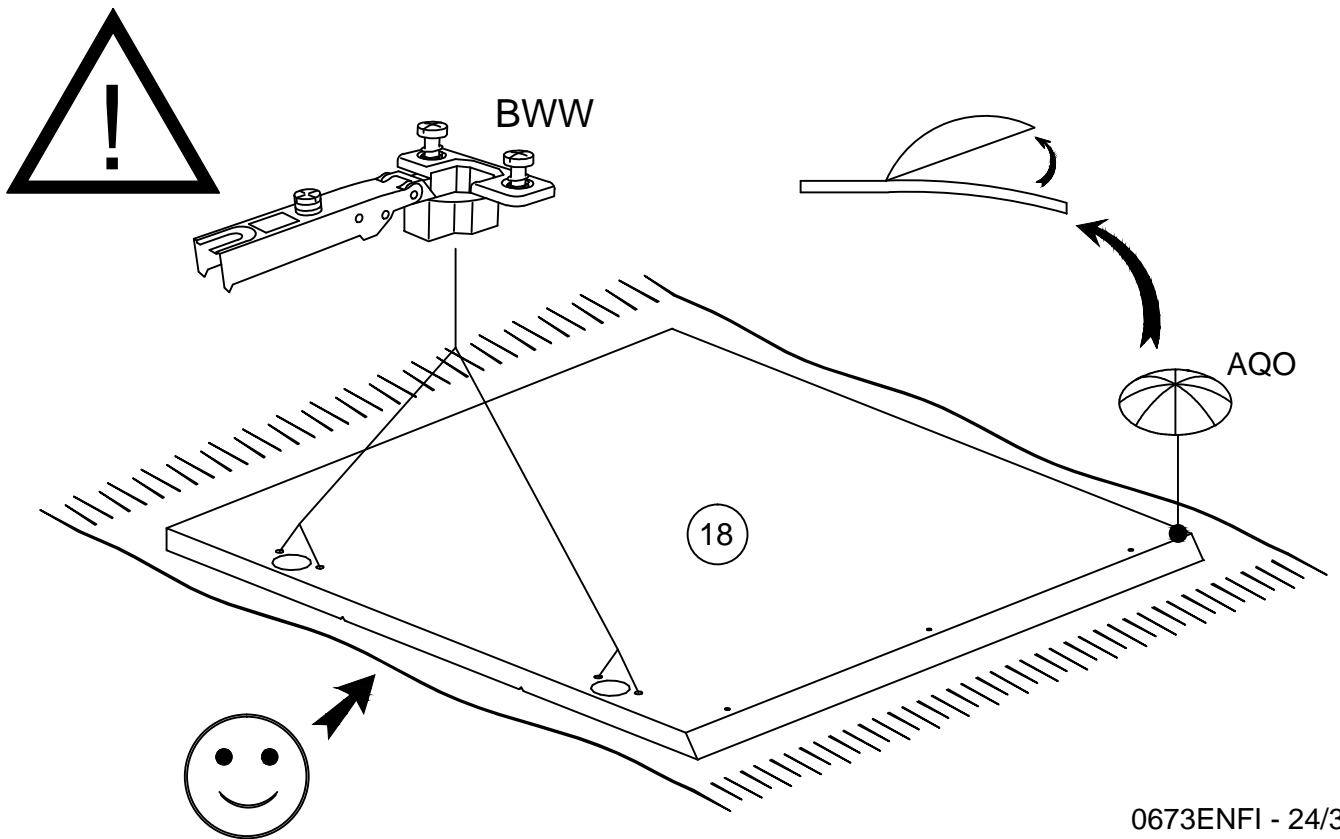
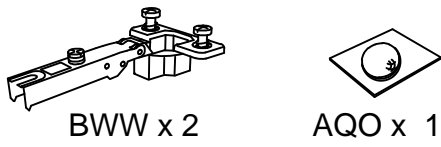

35

1216C

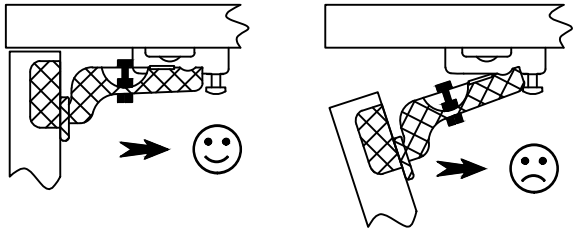
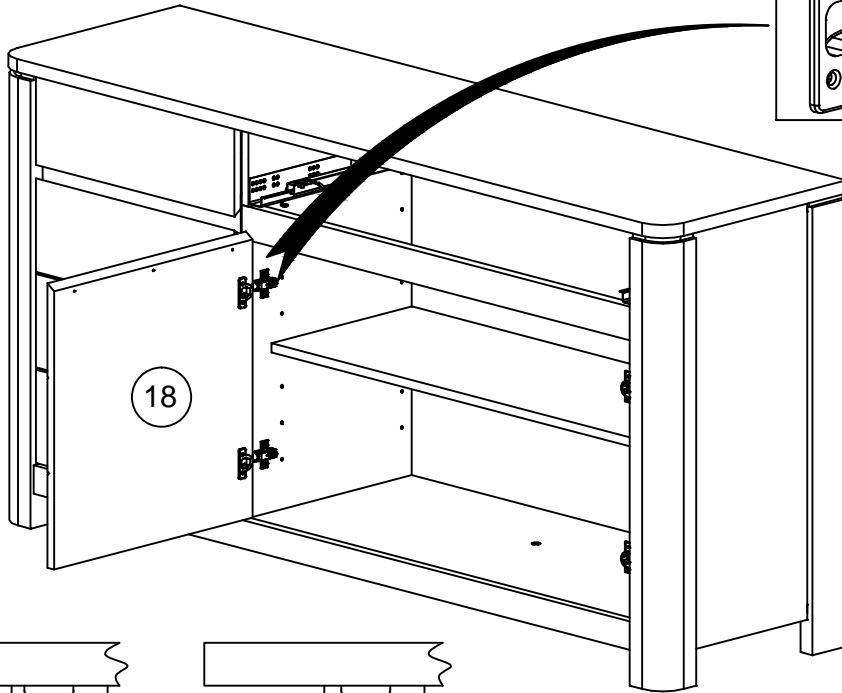

36

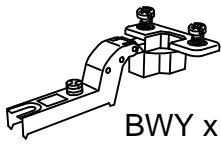

BWY x 2



AQO x 1

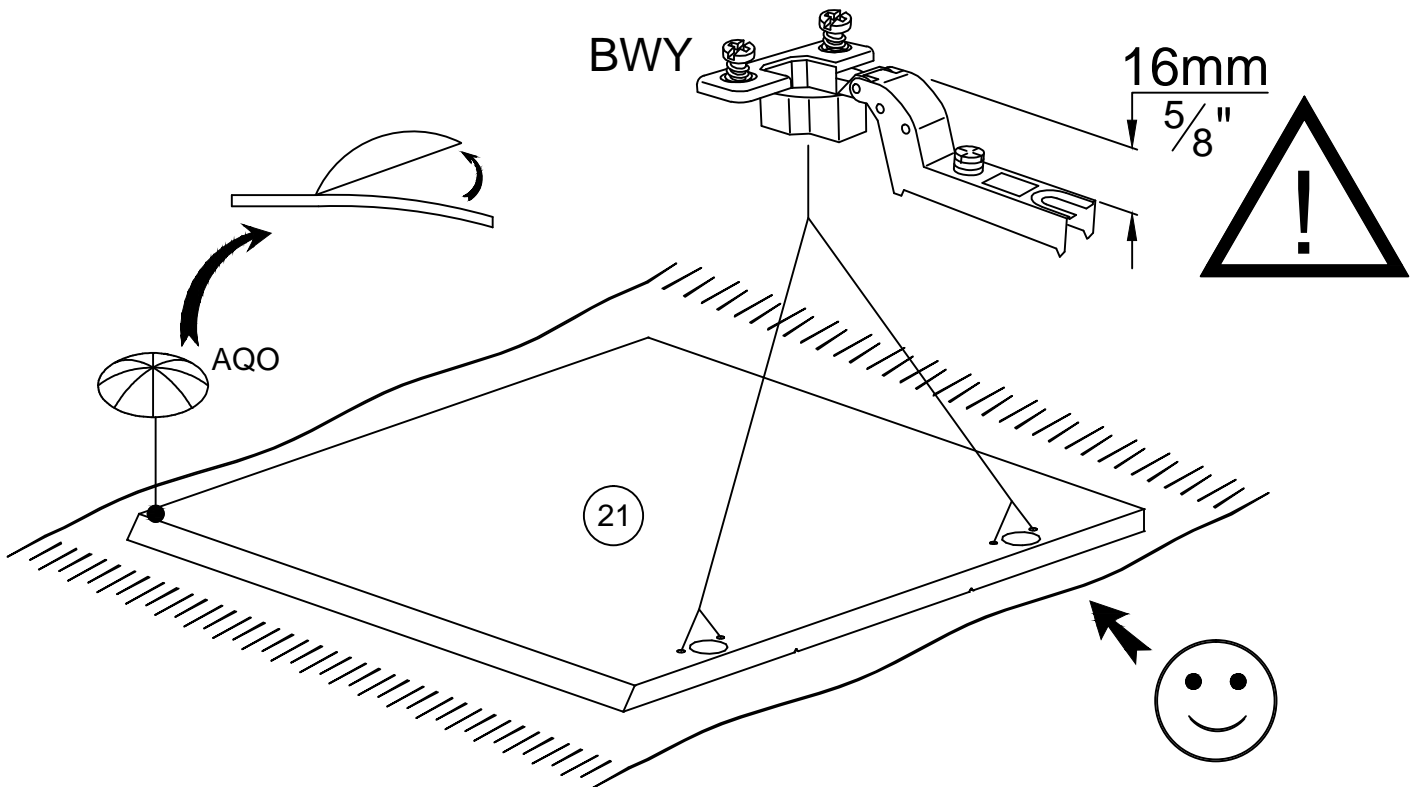

37

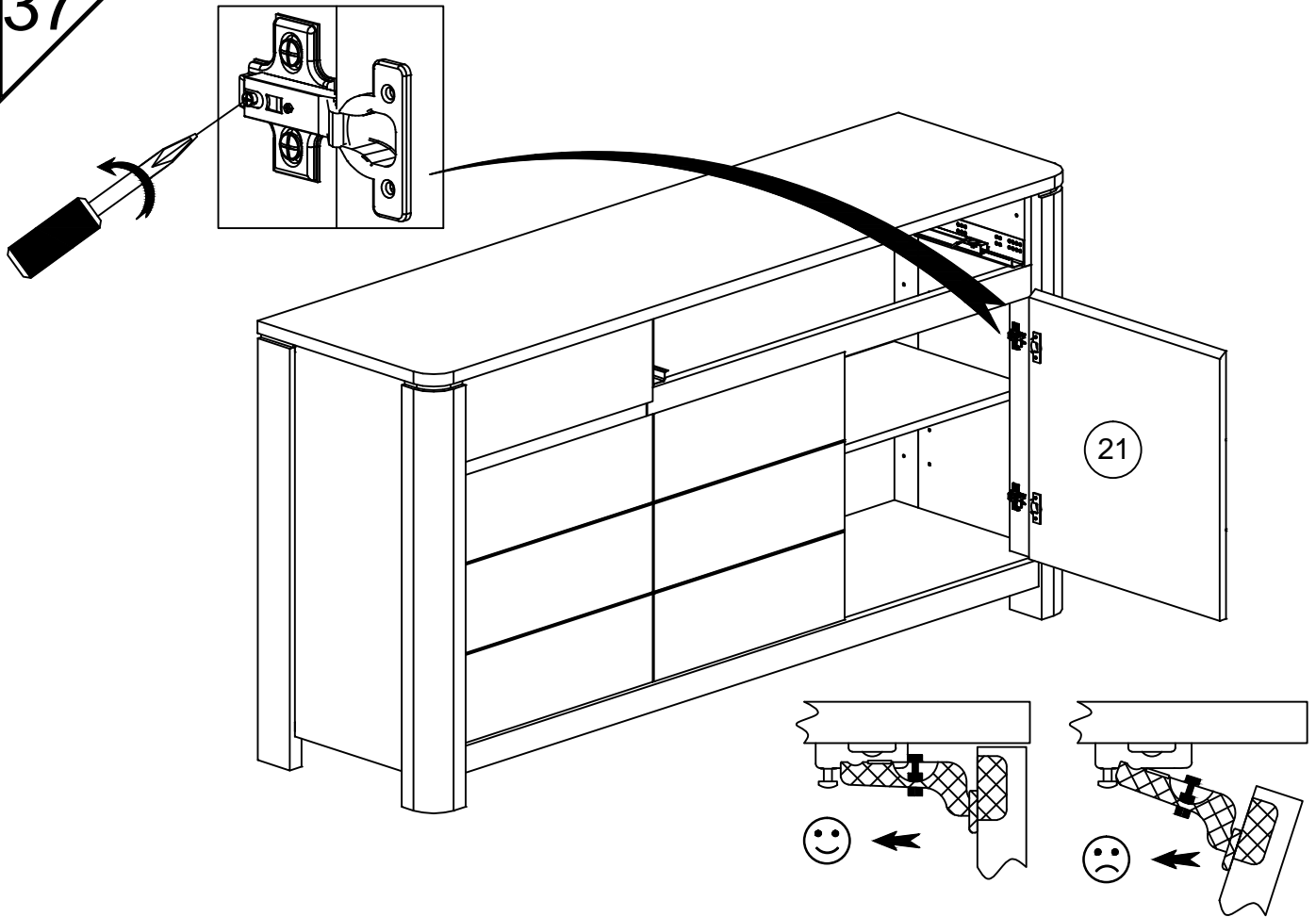

38

RCH-N

**MONTAGE**

- Ⓒ GB LEAFLET
- Ⓓ D AUFBAUANLEITUNG
- Ⓔ E MONTAJE
- ⒫ P MONTAGEM
- Ⓖ I MONTAGGIO
- Ⓗ F MONTAGE

AFSTELLING    Ⓒ GB ADJUSTING    Ⓔ E AJUSTER    Ⓖ I AGGIUSTAMENTO

                  Ⓓ D ANPASSUNG    ⒫ P REGULACAO    Ⓗ F REGLAGE

Ⓐ

Ⓑ

Ⓒ

39

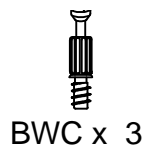

1216C

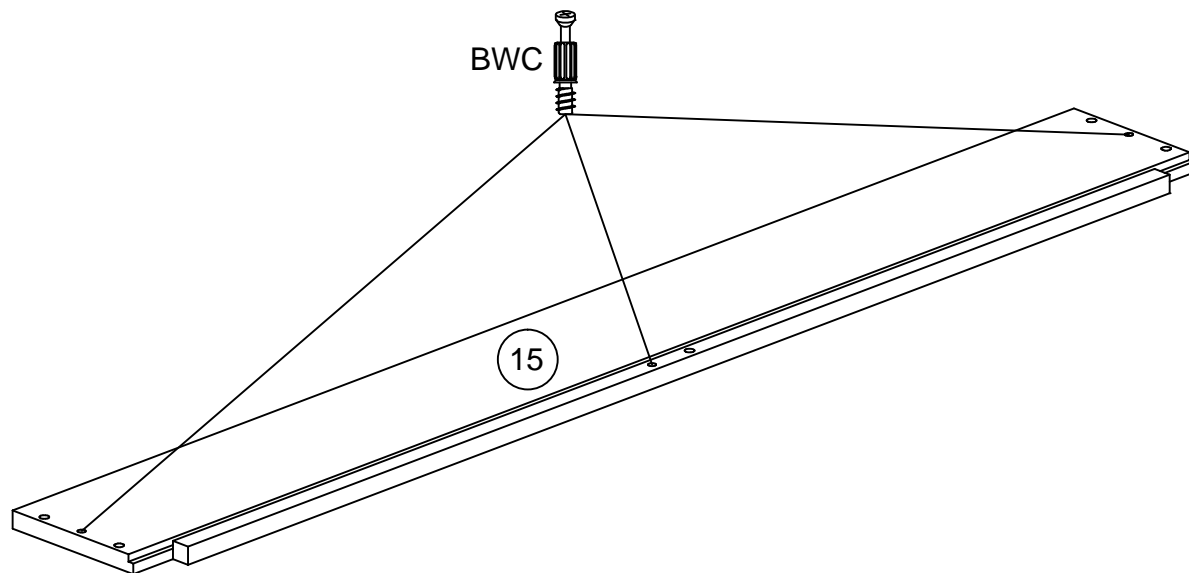

40

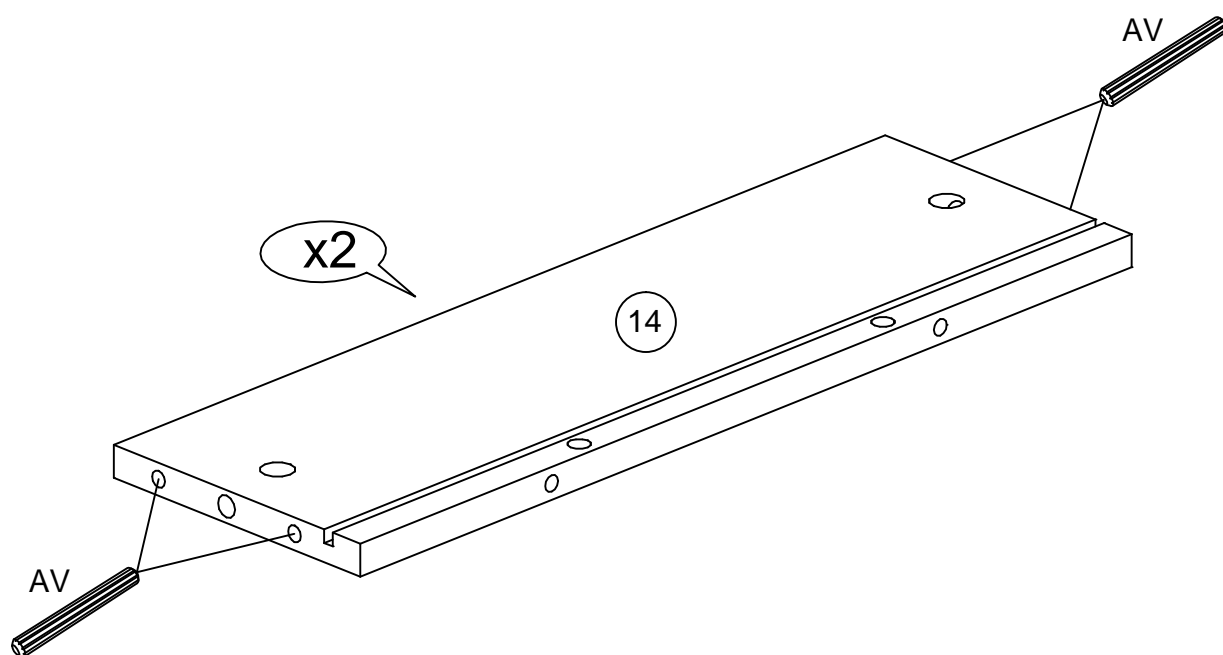

41



AV x 2

1216C

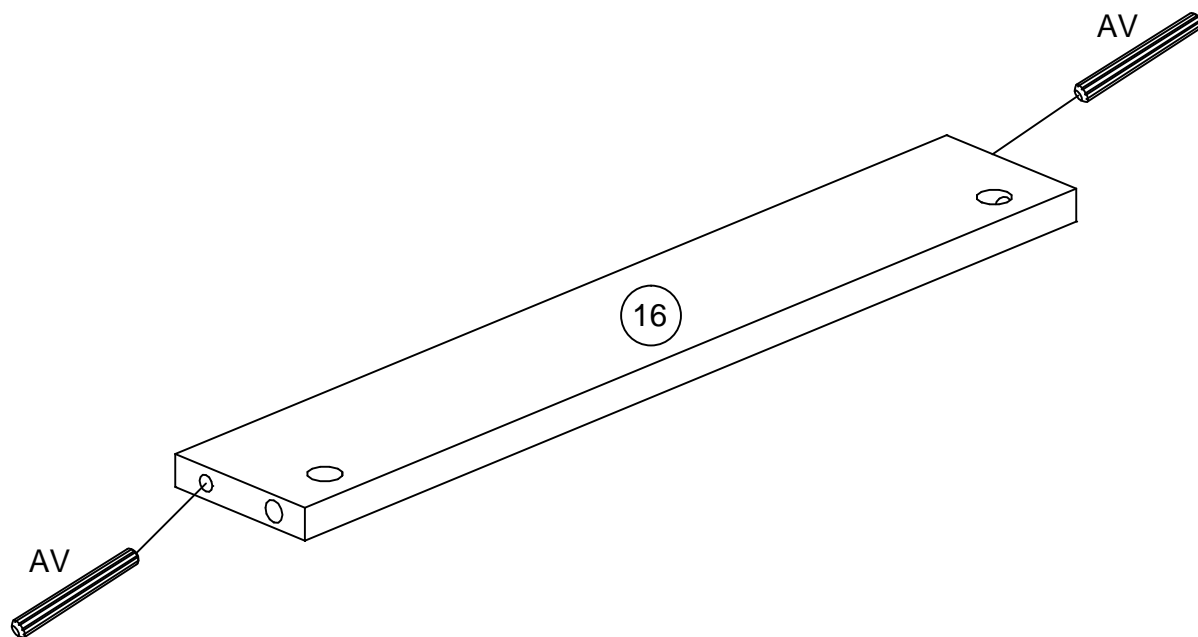

42



BZG x 3

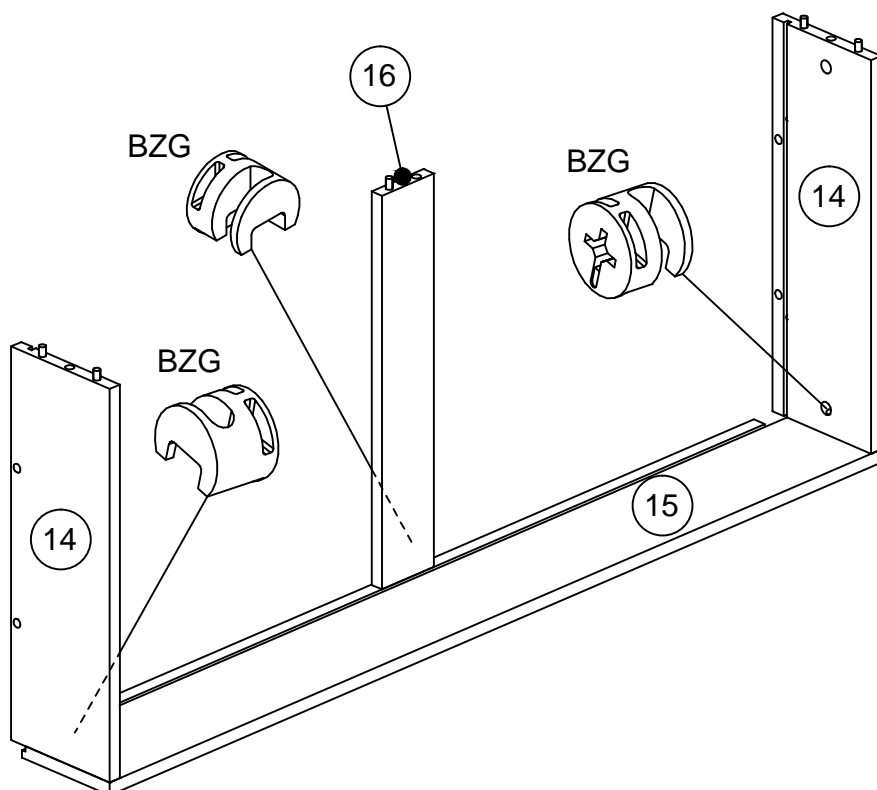

43

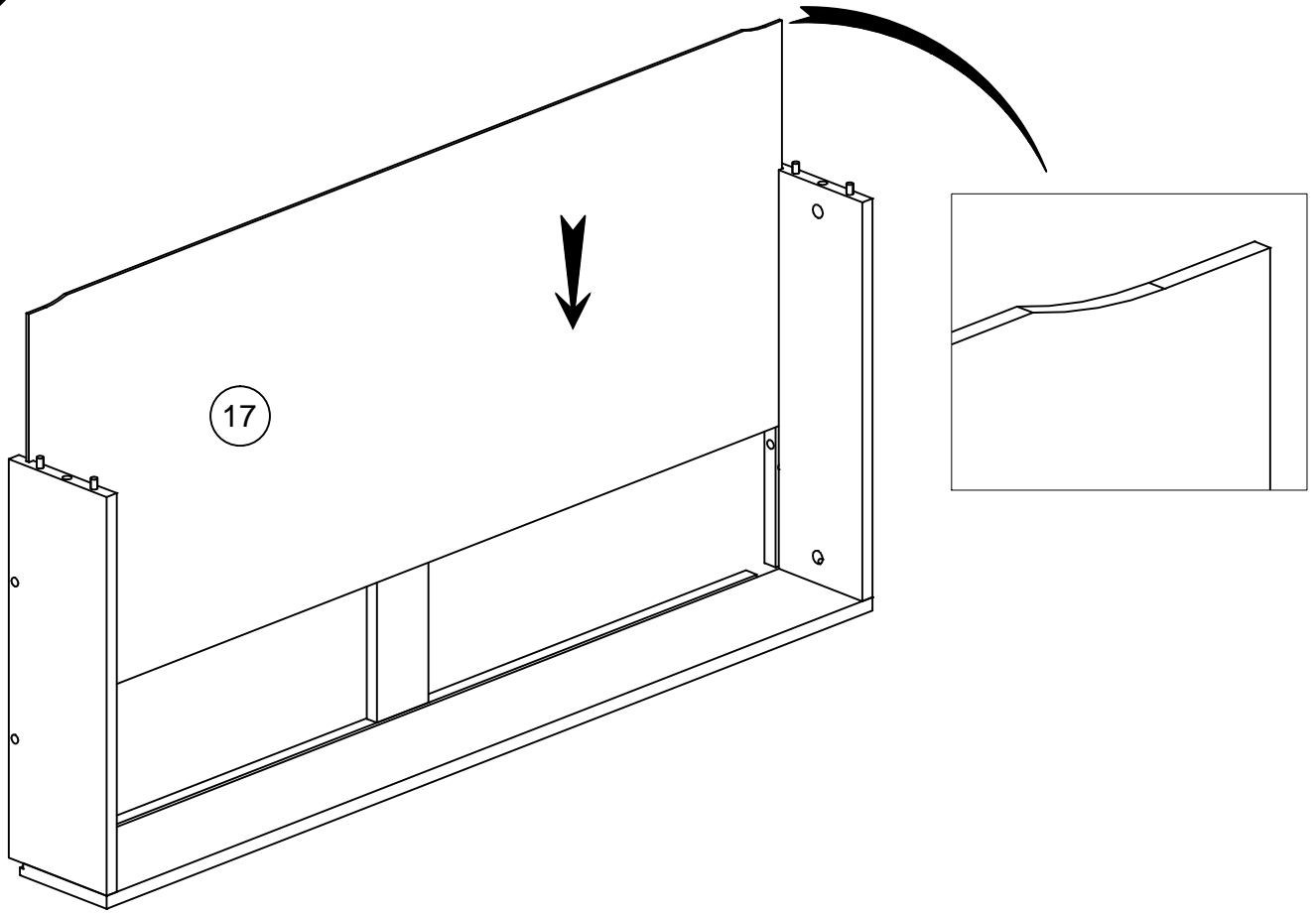

44

  
BWC x 3

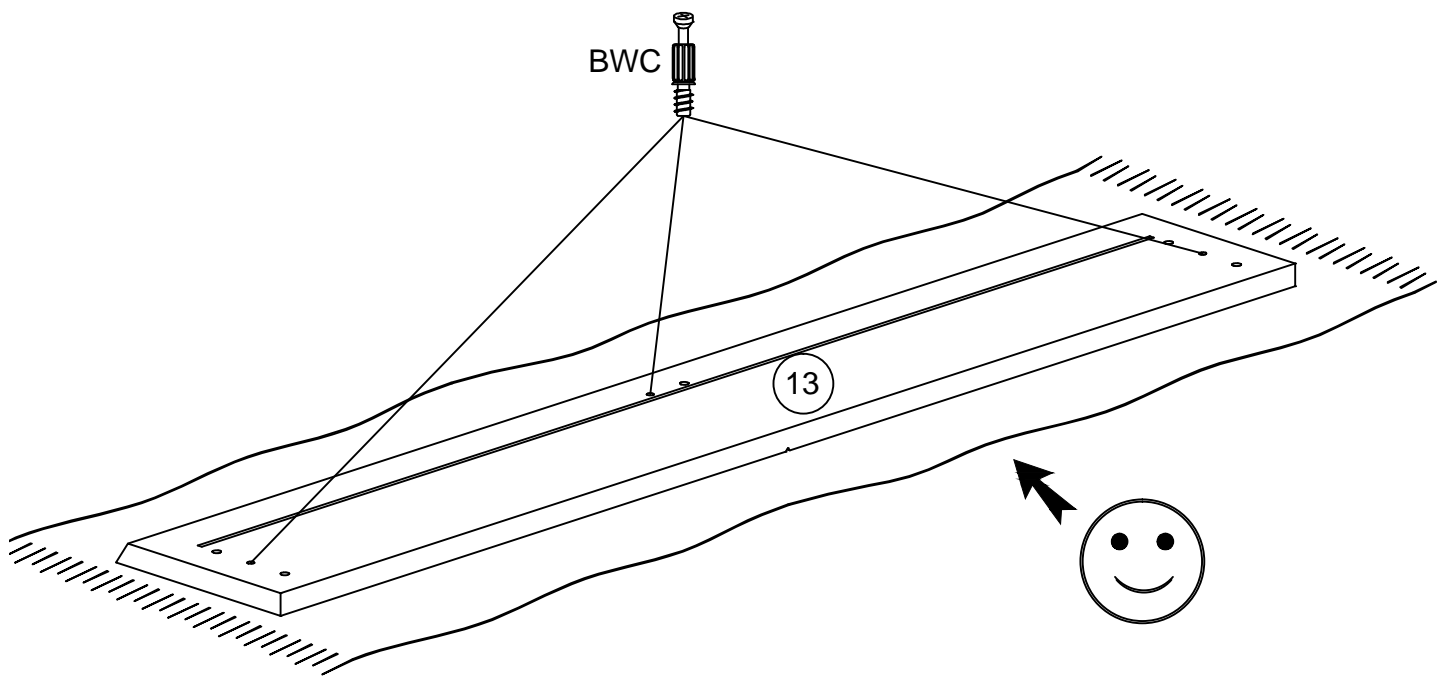

45



BZG x 3

1216C

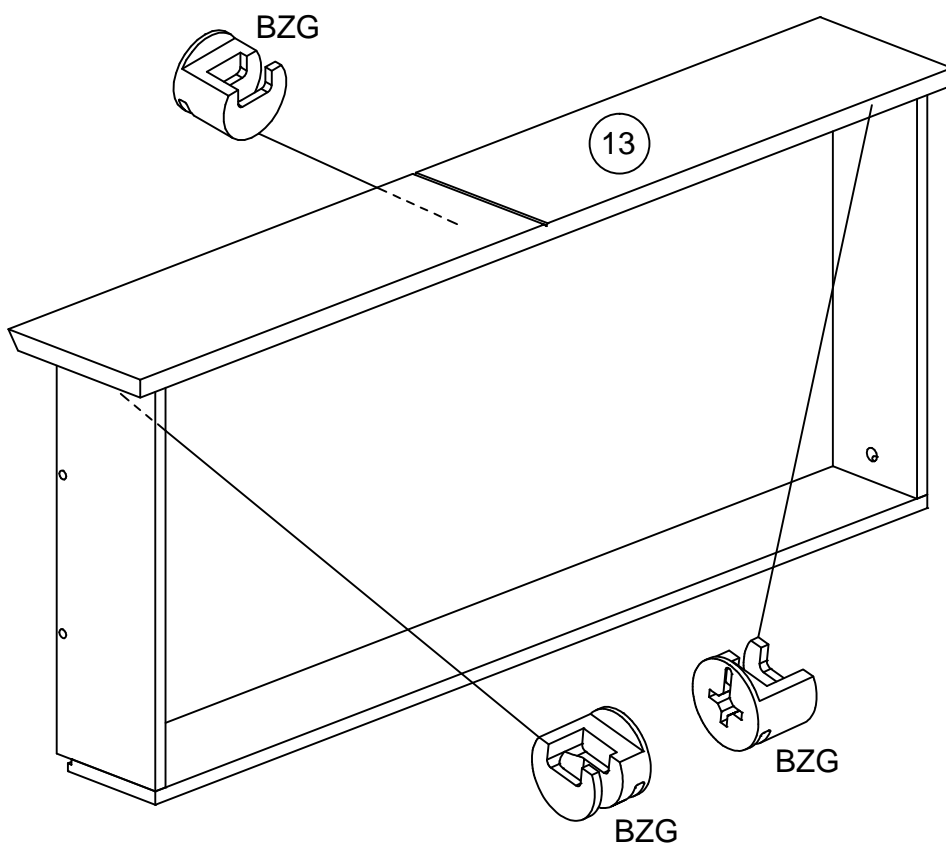

46

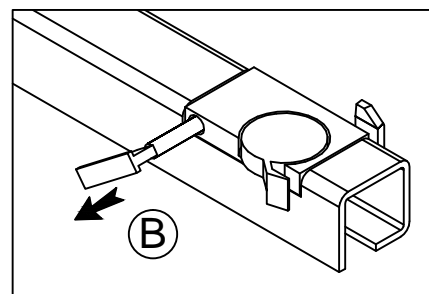
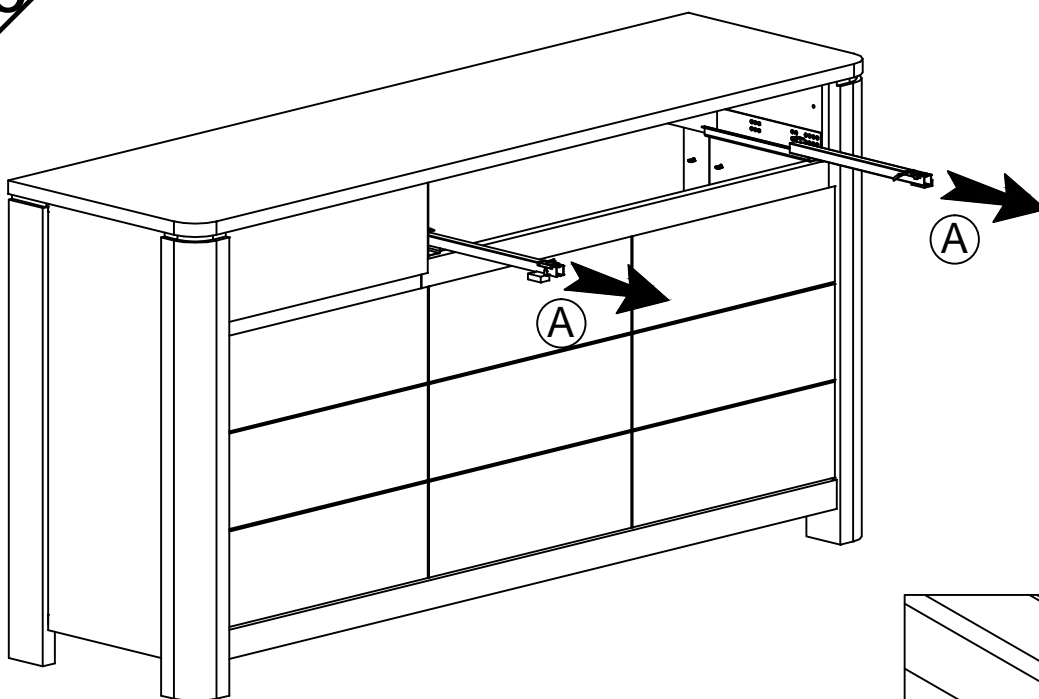

47

1216C

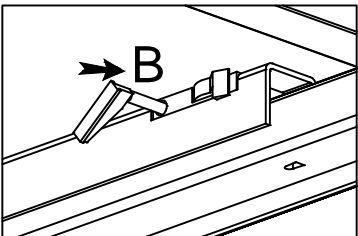
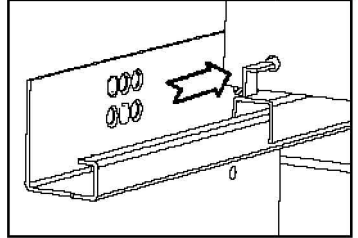
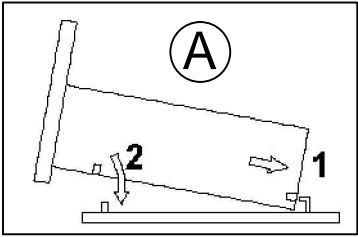
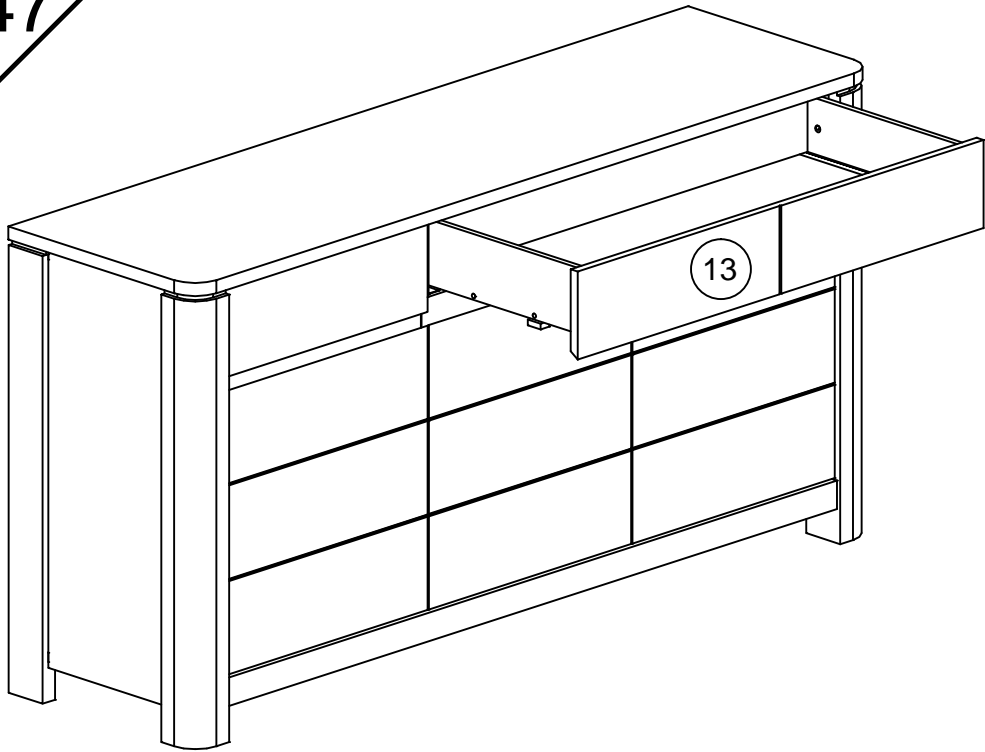

48

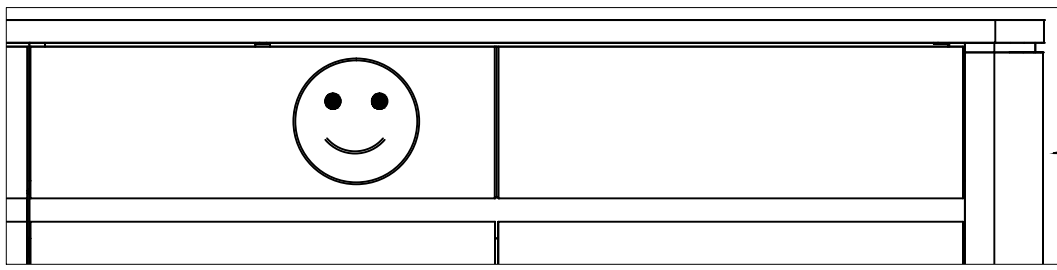
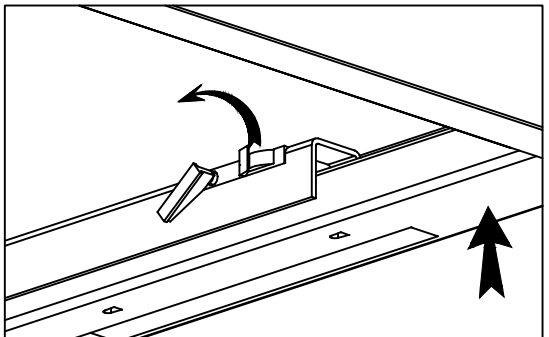
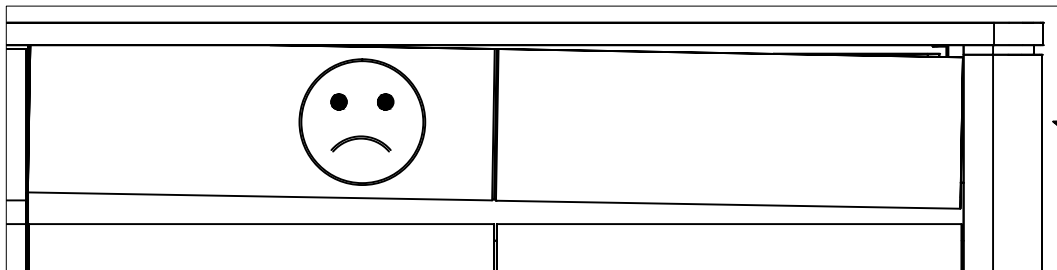



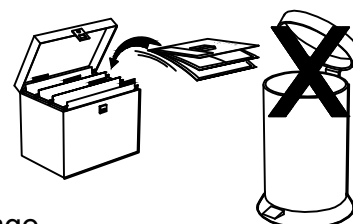
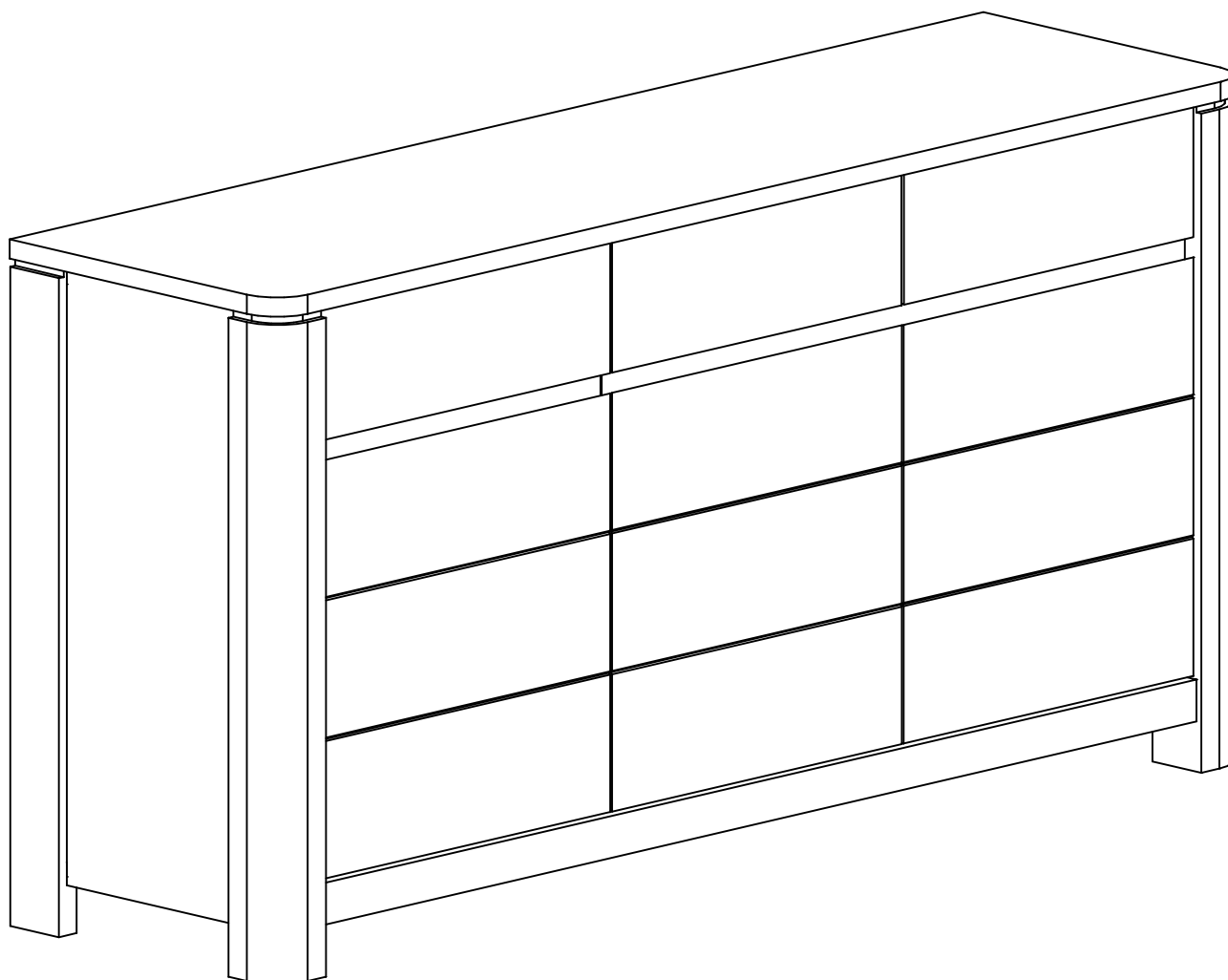

Faites un geste pour l'environnement en triant vos déchets d'emballage  
Make a gesture for the environment by sorting out your waste of packaging  
Machen Sie eine Bewegung für die Umwelt, ihre Verpackungsabfälle sortierend  
Haga un gesto para el medio ambiente escogiendo sus residuos de embalaje

## Conseils d'usage pour l'entretien de votre meuble

Félicitations pour l'achat de votre meuble.

Ce meuble est fabriqué avec soin en placage chêne, plus quelques parties massives chêne/hêtre. Le chêne et le hêtre sont des bois de feuillus résistants et appréciés depuis des générations dans nos intérieurs (une structure de bois toute en finesse et des nuances de teintes).

### **Caractéristiques:**

Le bois utilisé pour votre meuble est un produit naturel et unique qui est travaillé directement dans son pays d'origine après une sélection rigoureuse.

Chaque meuble est unique et a ses caractéristiques car aucun morceau de bois n'a la même couleur ni la même structure. Il est même possible que vous ayez des nuances de teintes sur un même meuble.

Des fissures, inégalités, ainsi que de petits ou de gros nœuds sont le résultat d'une croissance sur plusieurs années et de propriétés de l'arbre.

Des différences de couleur entre les meubles et celles du magasin, ne sont pas exclues (dû à l'éclairage, au soleil, etc.)

Un vernis a été appliqué sur votre meuble. Ce vernis forme la meilleure protection possible pour le bois. Le traitement par ce vernis accentue le contraste du bois.

### **Entretien :**

- a) Ne jamais utiliser de chiffons abrasifs mais toujours un tissu doux et légèrement humide, éviter de frotter la surface fortement.
- b) les produits de nettoyage doivent être des produits à base naturelle, jamais d'eau de Javel , d'alcool , de solvant, d'ammoniaque.
- c) produits suggérés : eau avec léger savon naturel ou produits pour le verre.

### **Recommandations :**

Resserrez les vis et les assemblages après quelques temps d'usage (lit, table, bureau, charnières).

Afin de prévenir d'inutiles pressions sur les points d'attache, nous vous recommandons de placer vos meubles sur une surface plane.

Si vous souhaitez déplacer votre meuble, pensez à le vider et enlever les tablettes verres. Sans cela, vous pourriez abimer le meuble et le sol.

Si vous posez des casseroles, cafetières, tasses, etc. nous vous recommandons d'utiliser des dessous de plats.

Si vous renversez un liquide, utiliser immédiatement un chiffon sec pour essuyer la surface jusqu'à ce qu'elle soit entièrement sèche.

### **Recommandations spécifiques pour les meubles hauts :**

Pour des raisons de sécurité, tous les meubles hauts disposent d'un dispositif d'accrochage au mur, disponible à l'intérieur de votre colis. Si tel n'est pas le cas, veuillez en faire la demande auprès de votre revendeur. Cela empêche toute chute accidentelle du meuble.

La qualité de nos produits et votre entière satisfaction, font l'objet de toute notre attention. En cas de questions ou de remarques, n'hésitez pas à en faire part à votre revendeur.

Nous espérons que ce meuble vous apportera entière satisfaction.