

1H30 min

2978/9
1017s40

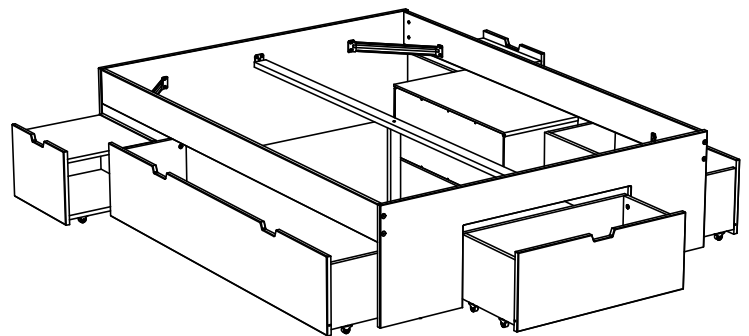

Votre meuble se recycle.
Renseignez-vous auprès de
votre centre de tri.

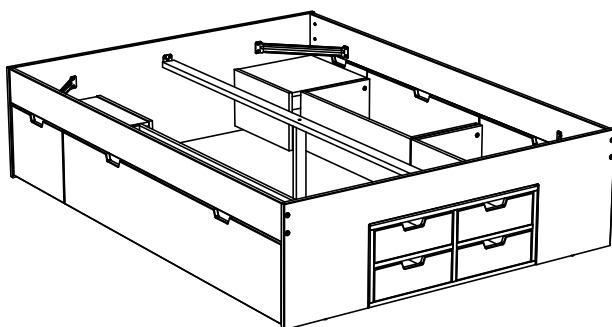
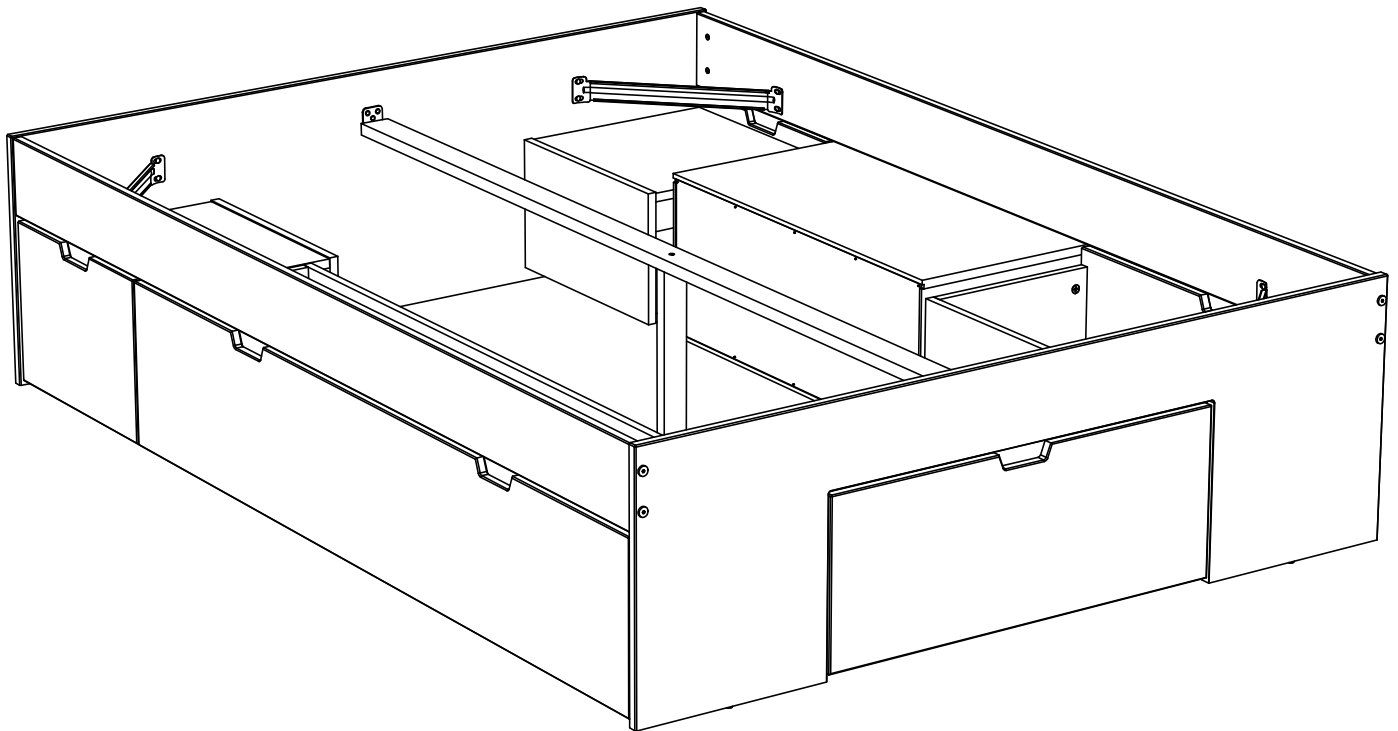

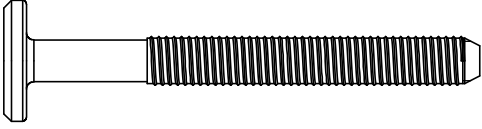

1/4 - 3/4 - 4/4

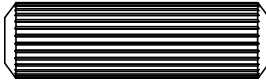
 M6 x 60mm	
A : 8x	8 (1/4)

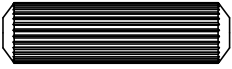
 Ø 10 x 35mm	
B : 4x	4 (1/4)

 Ø 8 x 30mm	
C : 78x	14 (1/4) - 48 (3/4) - 16 (4/4)

 Ø 8 x 50mm	
D : 2x	2 (3/4)

	
E : 68x	24 (1/4) - 28 (3/4) - 16 (4/4)

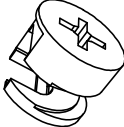
 Ø 15mm	
F : 68x	24 (1/4) - 28 (3/4) - 16 (4/4)

 M6	
G : 8x	8 (1/4)

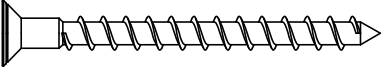
 Ø 4,5 x 50mm	
H : 1x	1 (1/4)

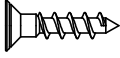
 Ø 3,5 x 15mm	
I : 12x	12 (1/4)

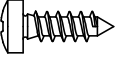
 TR Ø 4 x 16mm	
J : 40x	24 (1/4) - 16 (4/4)

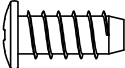
 Ø 6,3 x 14mm	
K : 16x	16 (1/4)

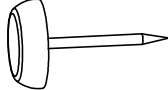
	
L : 4x	4 (3/4)

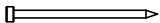
	
M : 12x	12 (3/4)

 Ø 17mm	
N : 4x	4 (1/4)

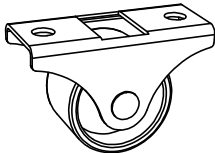
	
O : 20x	12 (1/4) - 8 (4/4)

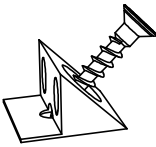
	
P : 2x	2 (1/4)

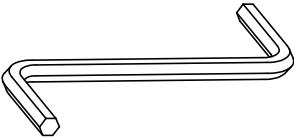
	
Q : 1x	1 (1/4)

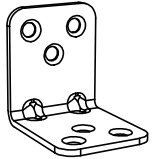
	
R : 2x	2 (1/4)

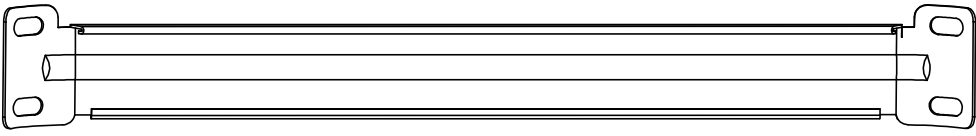

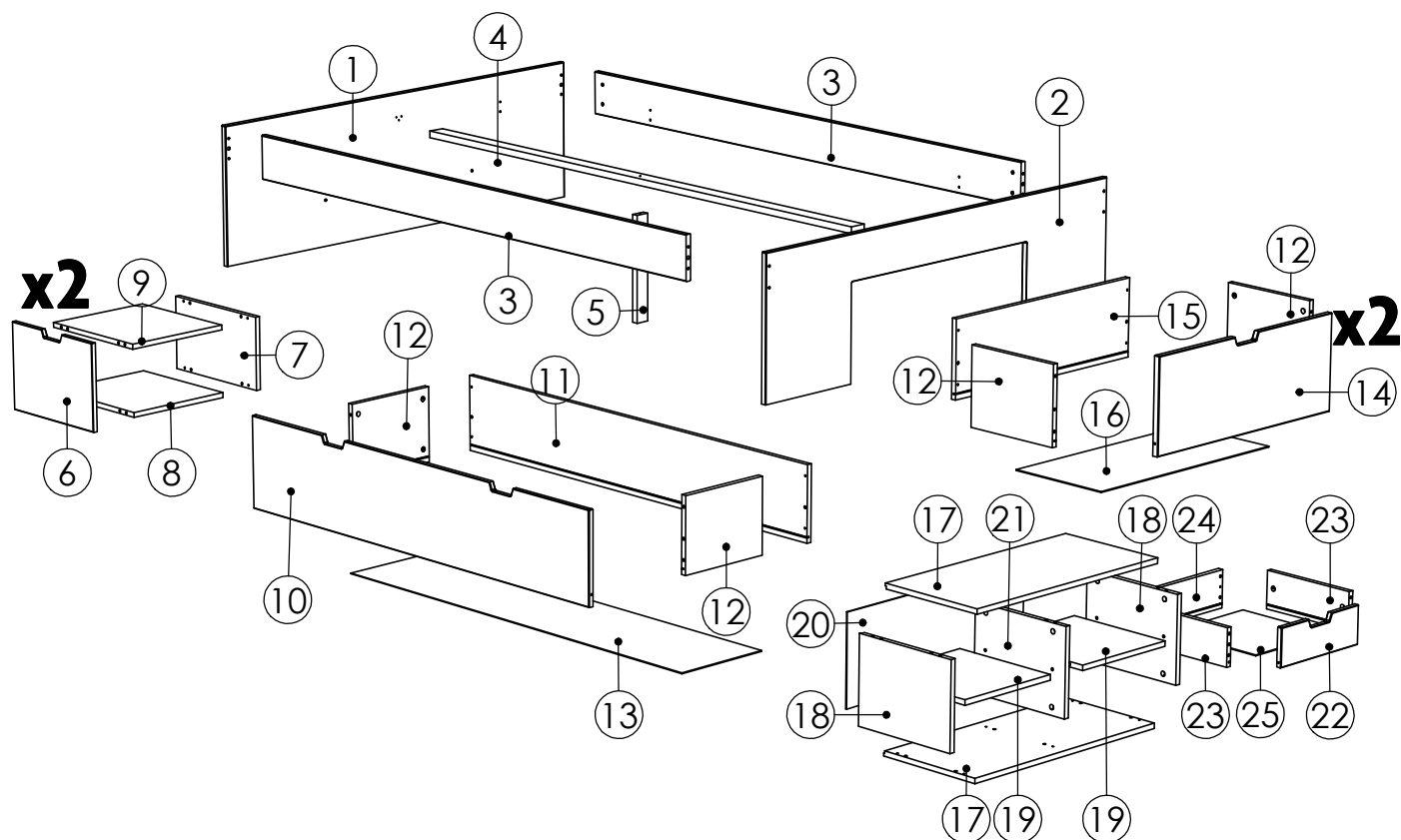
	
S : 4x	4 (1/4)

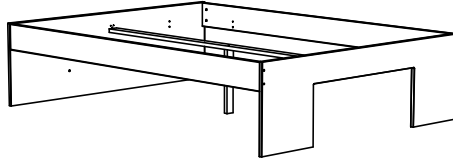

N° PIECE	QTE	Longueur	Largeur	Colis
1	1	1444	450	2/4
2	1	1444	450	2/4
3	2	1890	140	1/4
4	1	1875	55	1/4
5	1	342	45	2/4
6	2	400	290	4/4
7	2	400	243	4/4
8	2	398	367	4/4
9	2	398	367	4/4
10	1	1478	290	1/4
11	1	1478	240	1/4
12	6	312	240	1/4
13	1	1459	327	2/4
14	2	735	290	2/4
15	2	735	240	2/4
16	2	716	327	2/4
17	2	735	350	3/4
18	2	350	268	3/4
19	2	346	342,50	3/4
20	1	720	283	3/4
21	1	346	268	3/4
22	4	338	120	3/4
24	4	338	118	3/4
23	8	313	118	3/4
25	4	319	328	3/4



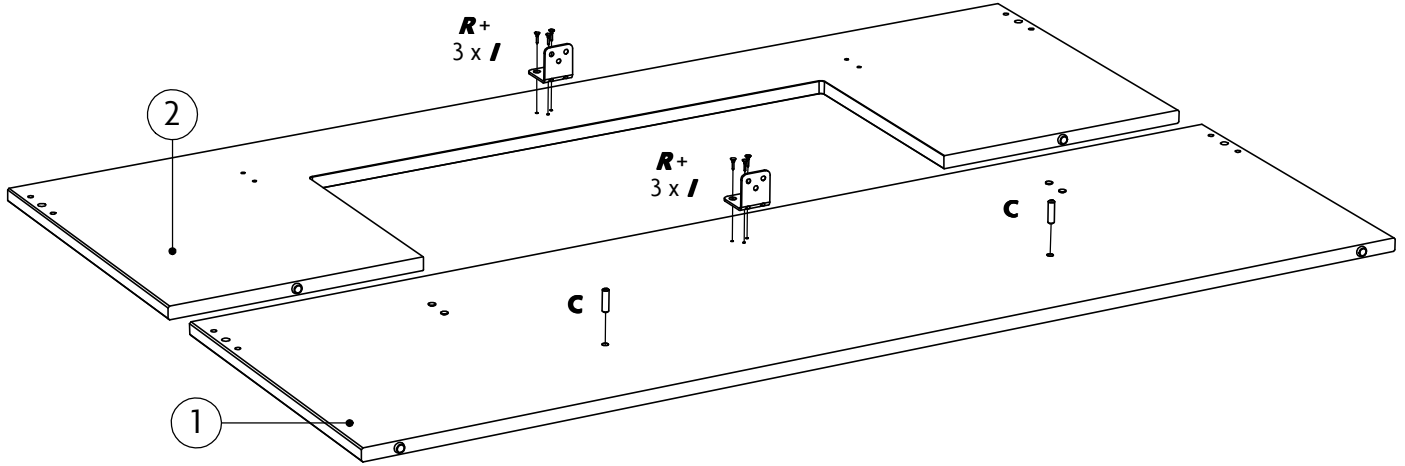

ETAPE 1

$\varnothing 8 \times 30\text{mm}$  C x 2	$\varnothing 3,5 \times 15\text{mm}$  I x 6	 R x 2
---	---	--



ETAPE 2

x2

$\varnothing 10 \times 35\text{mm}$  B x 4	M6  G x 8
--	---

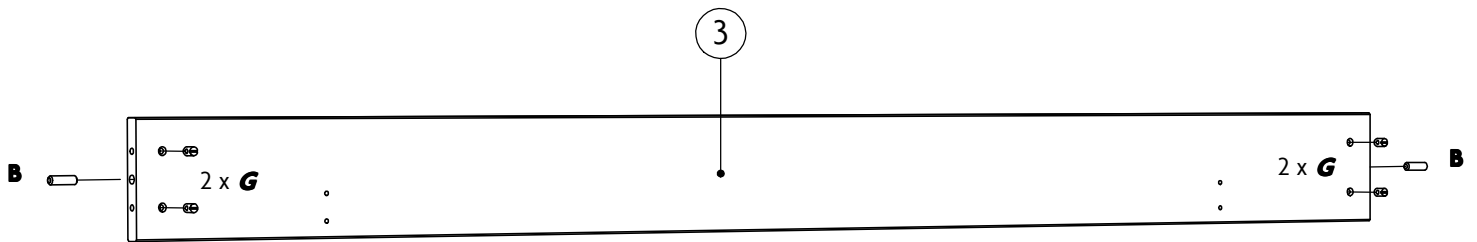

ETAPE 3

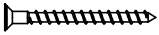
$\varnothing 4,5 \times 50\text{mm}$  H x 1

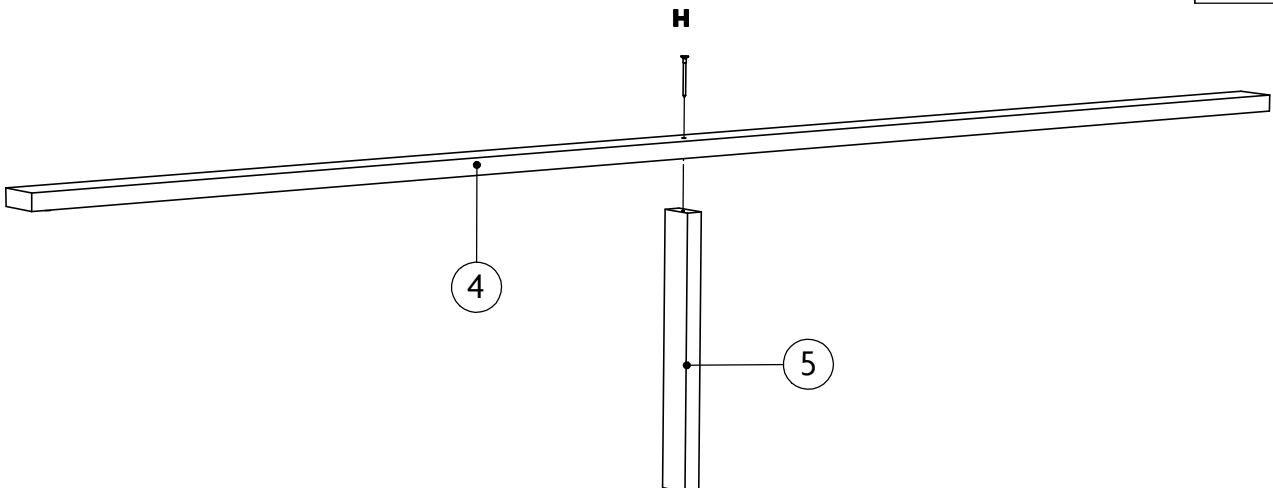

ETAPE 4

M6 x 60mm

**A** x 8

Ø 17mm

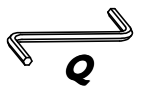
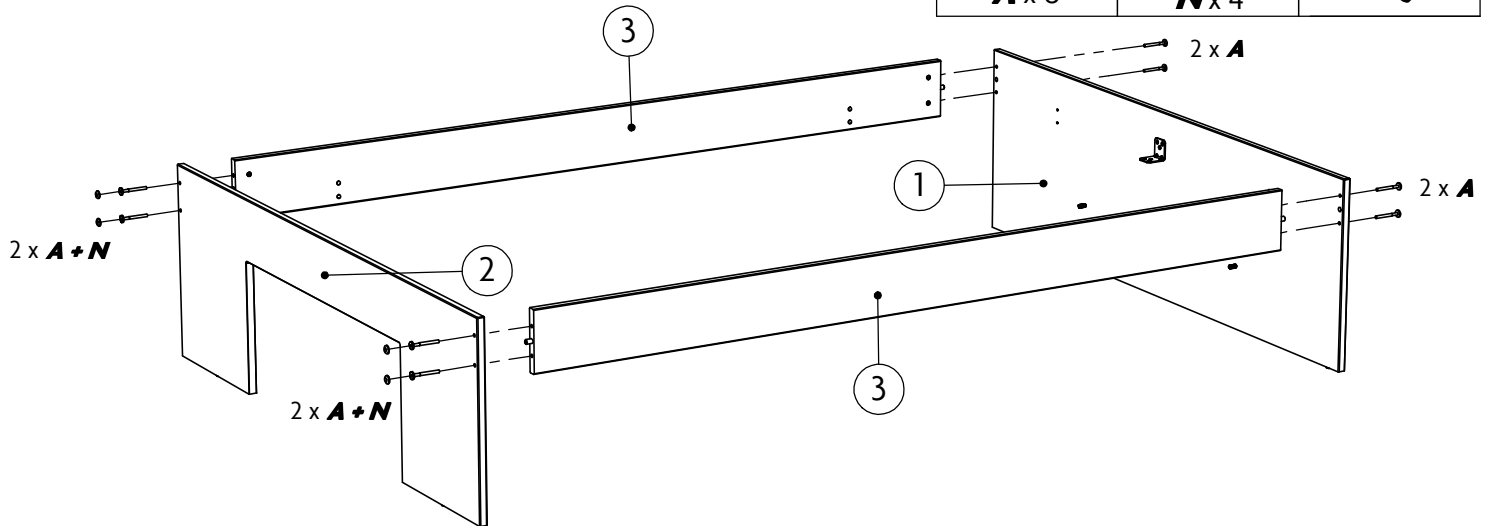
**N** x 4**Q**

ETAPE 5

Ø 6,3 x 14mm

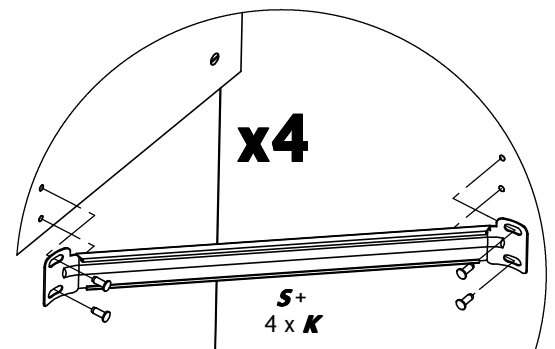
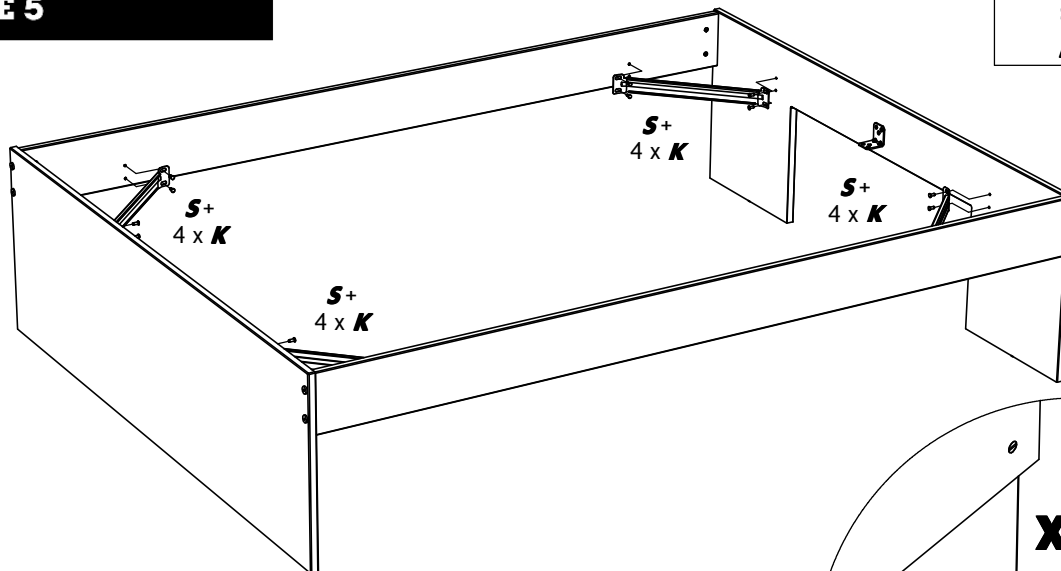
**K** x 16**S** x 4

ETAPE 6

Ø 3,5 x 15mm

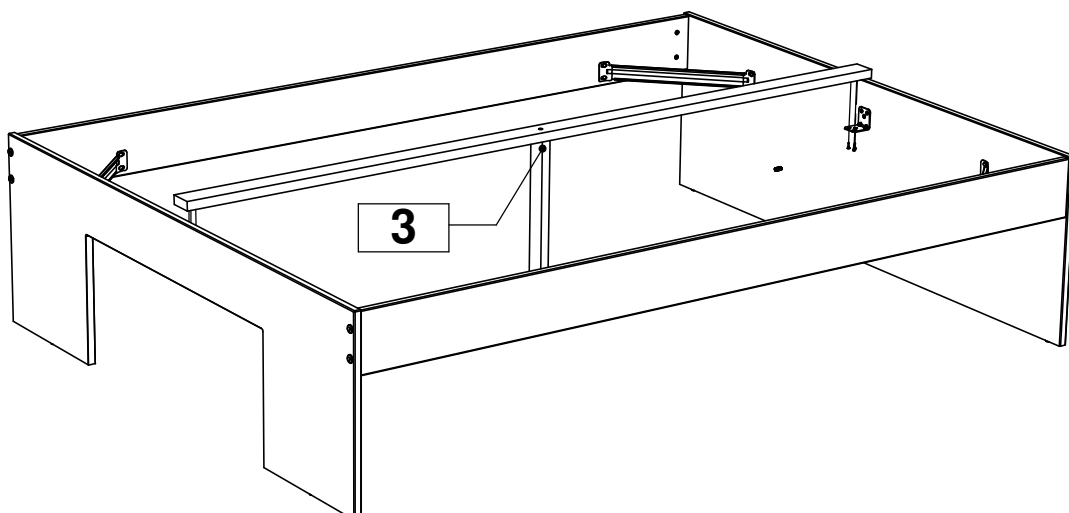
**I** x 6

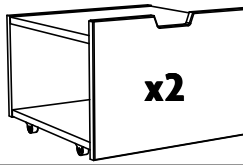

ETAPE 7

x2

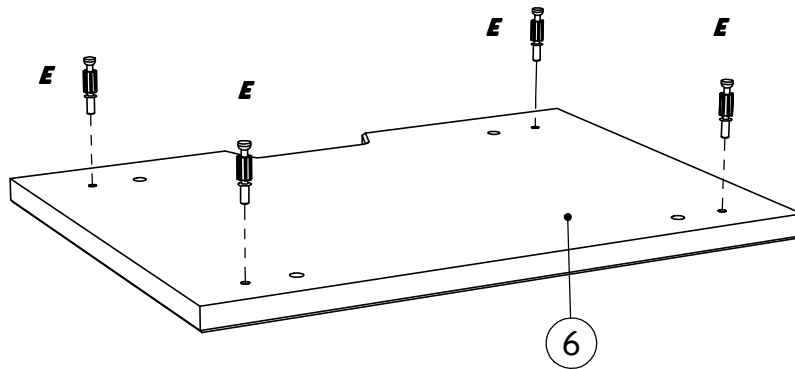
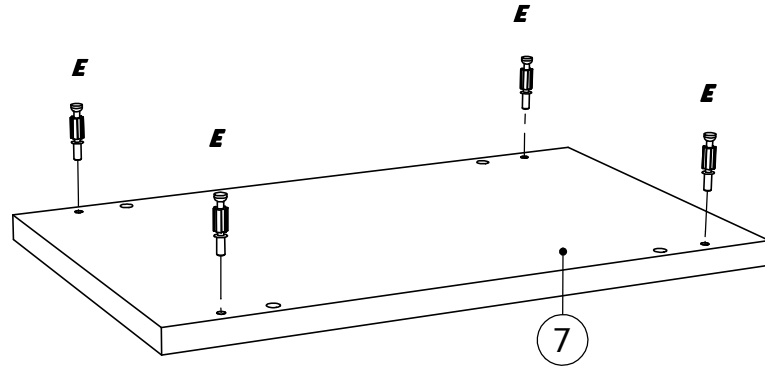
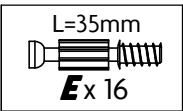

ETAPE 8

x2

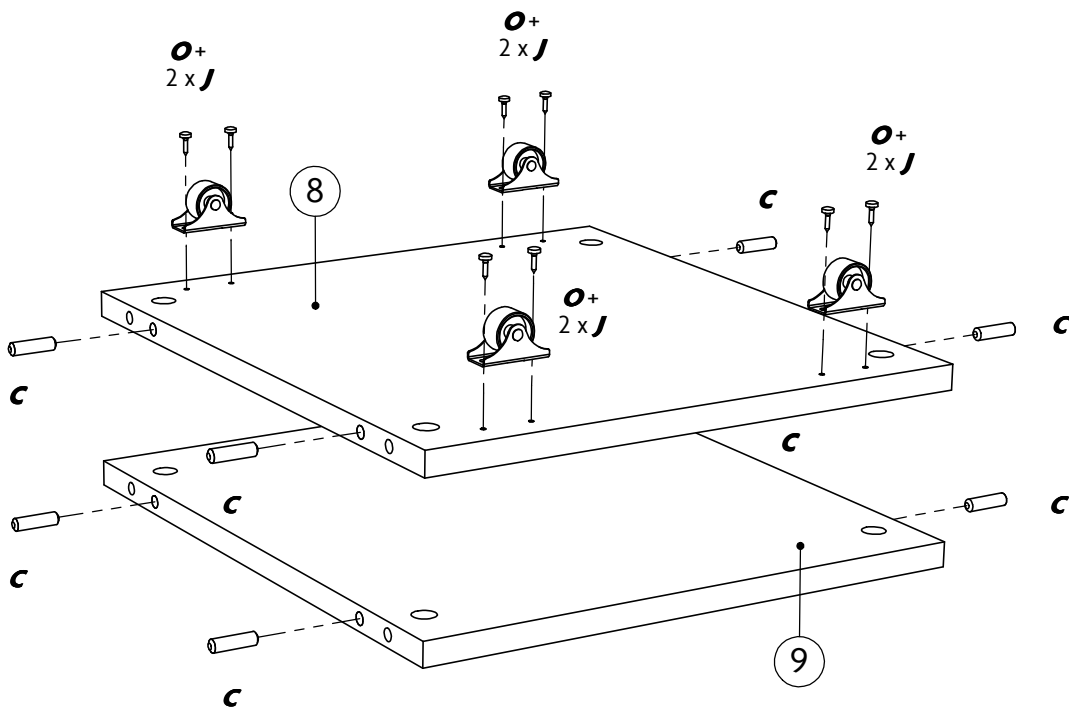
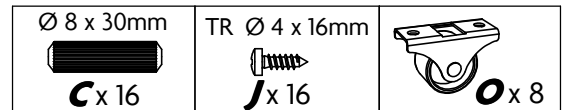

ETAPE 9

x2

Ø 15mm

F x 16

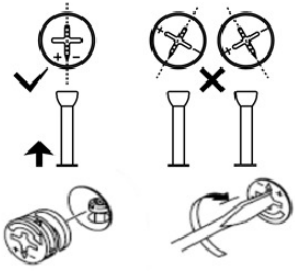

Avant de raccorder les excentriques, bien s'assurer que la position de départ est correcte avant d'insérer le boulon de connection.

Puis tourner dans le sens horaire jusqu'à la butée.

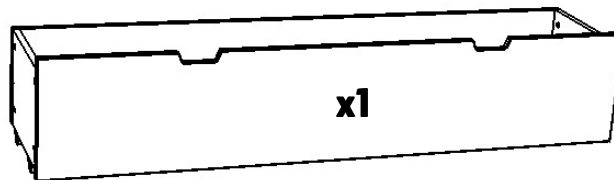
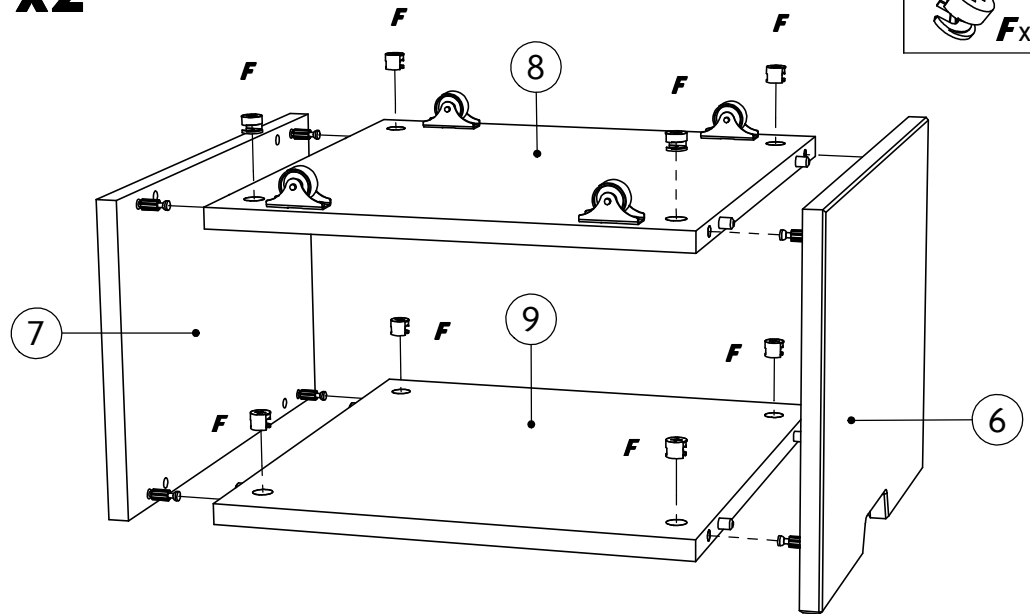

ETAPE 10

x2

O+

2 x J

O+

2 x J

Ø 8 x 30mm

C x 4

TR Ø 4 x 16mm

J x 8

O x 4

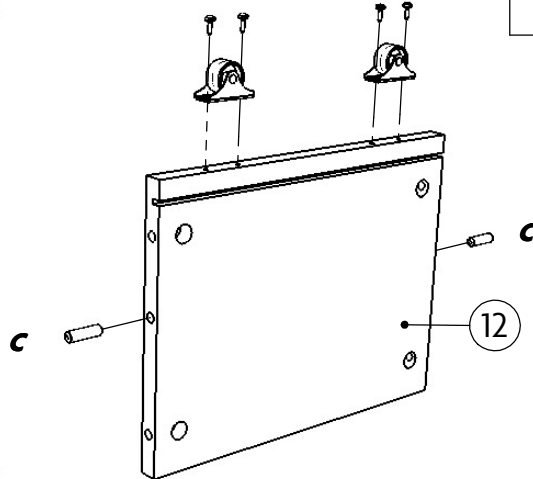

ETAPE 11

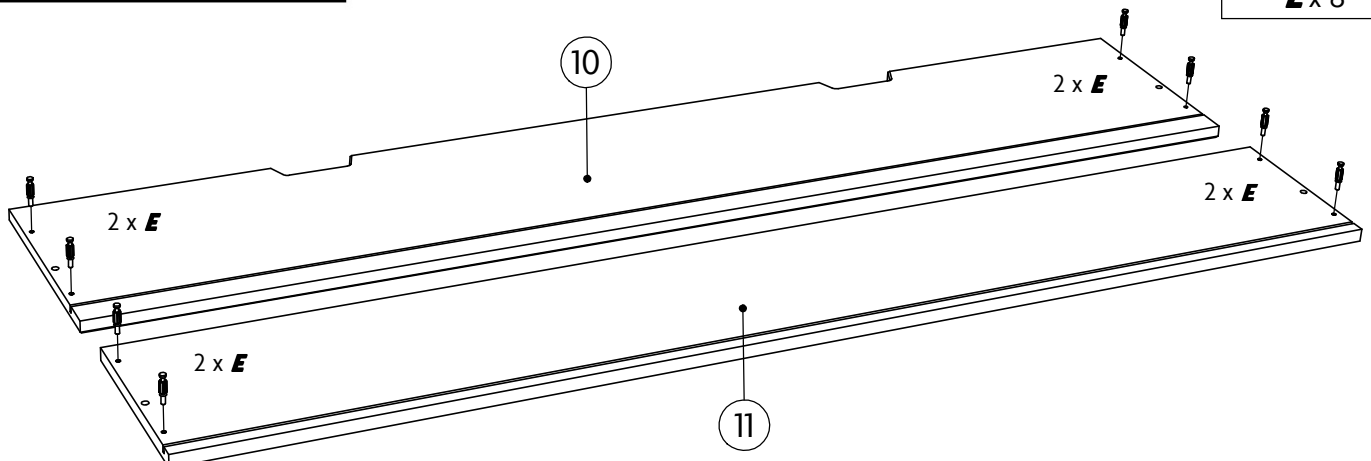
L=35mm
E x 8

ETAPE 12

Ø 15mm
 **F** x 4

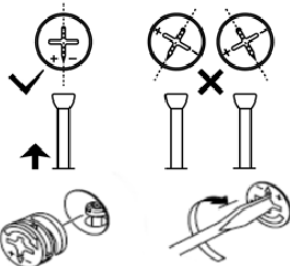
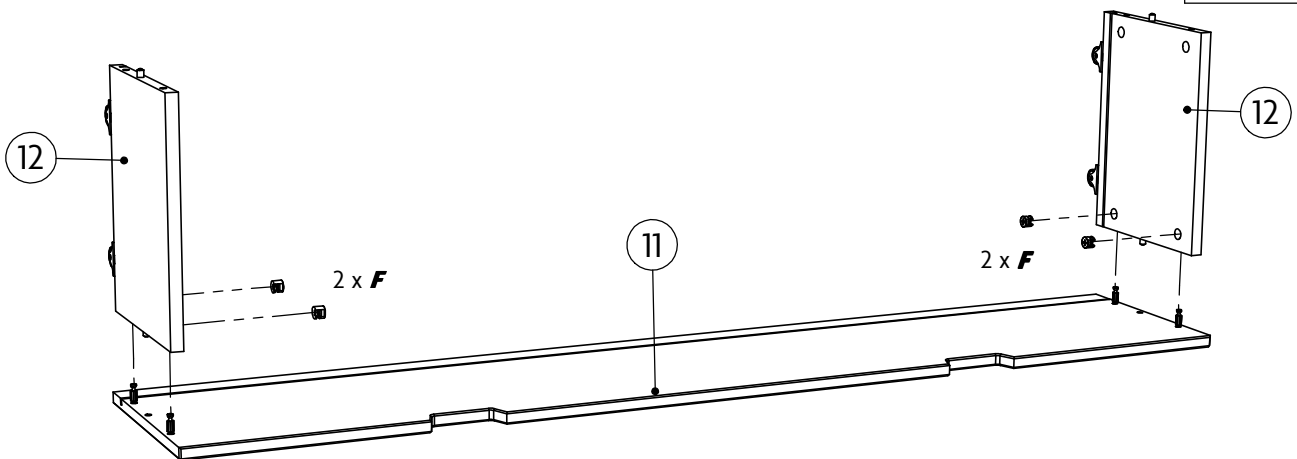

Avant de raccorder les excentriques, bien s'assurer que la position de départ est correcte avant d'insérer le boulon de connection.

Puis tourner dans le sens horaire jusqu'à la butée.

ETAPE 13

Ø 15mm
 **F** x 4

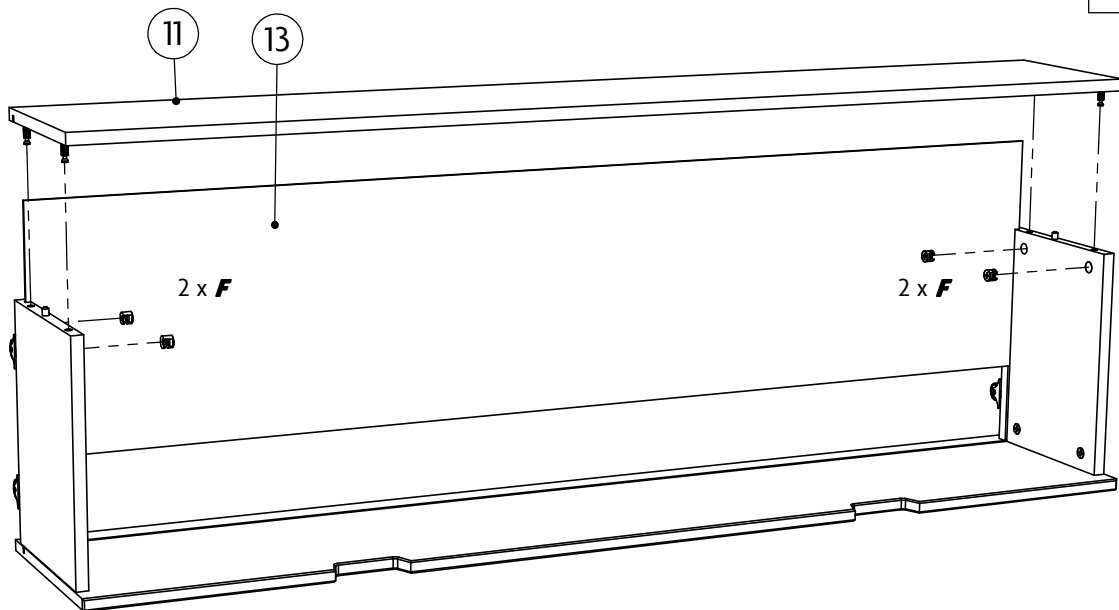

ETAPE 14

 **P** x 2

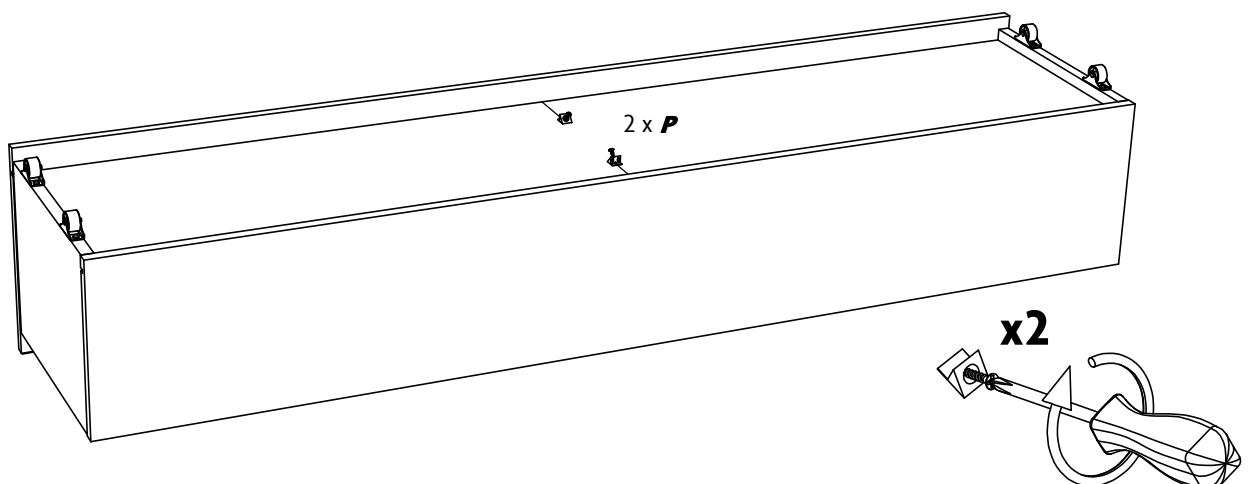

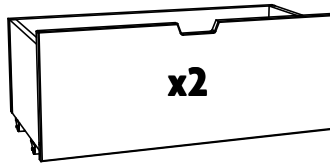

ETAPE 15

x4

O+
2 x J

O+
2 x J

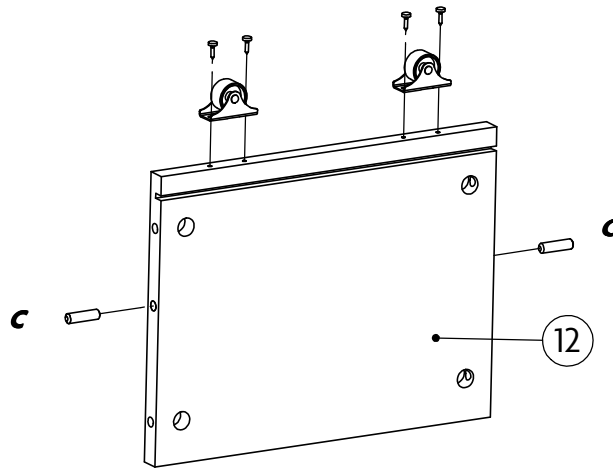
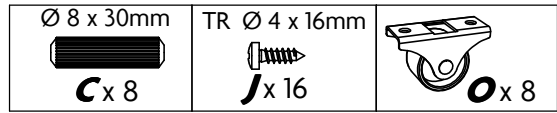

ETAPE 16

x2

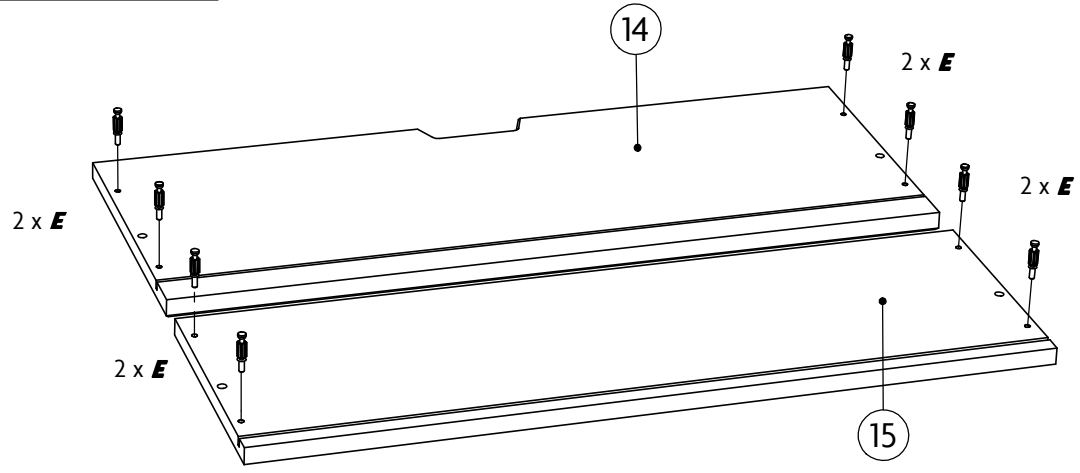
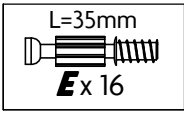

ETAPE 17

x2

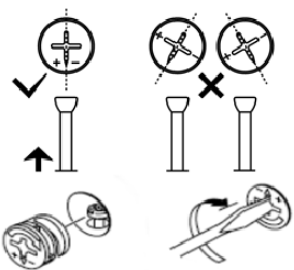
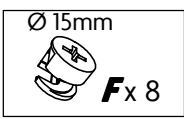

Avant de raccorder les excentriques, bien s'assurer que la position de départ est correcte avant d'insérer le boulon de connection.

Puis tourner dans le sens horaire jusqu'à la butée.

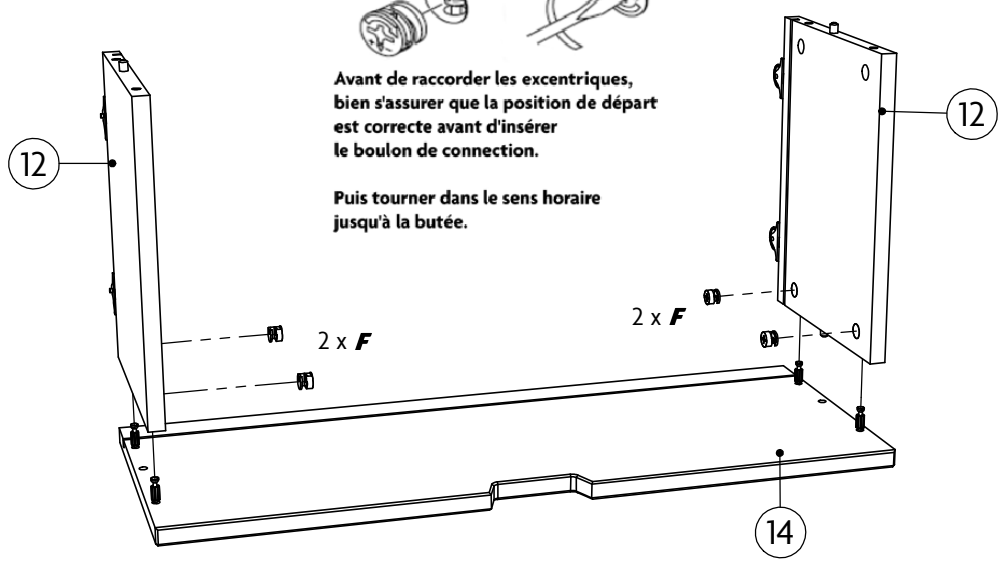

ETAPE 18

x2

Ø 15mm

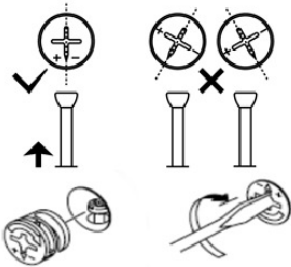
F x 8

Avant de raccorder les excentriques, bien s'assurer que la position de départ est correcte avant d'insérer le boulon de connection.

Puis tourner dans le sens horaire jusqu'à la butée.

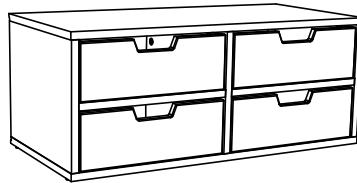
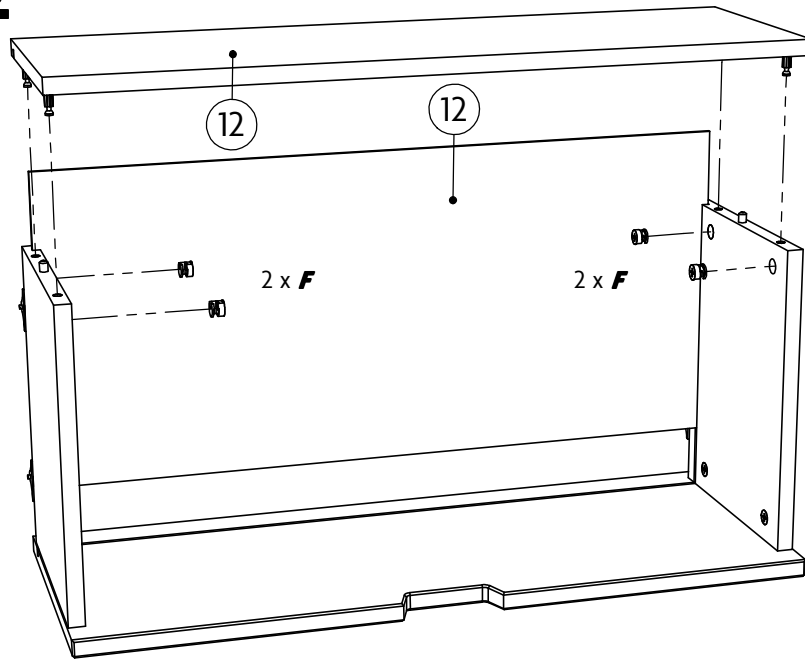

ETAPE 19

Ø 8 x 30mm

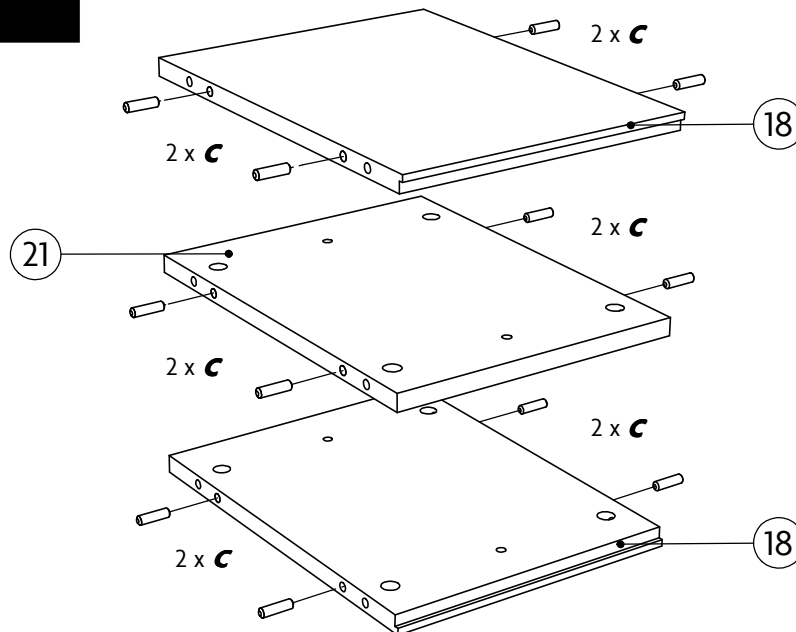
C x 12

ETAPE 20

x2

L=35mm

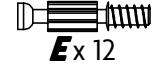
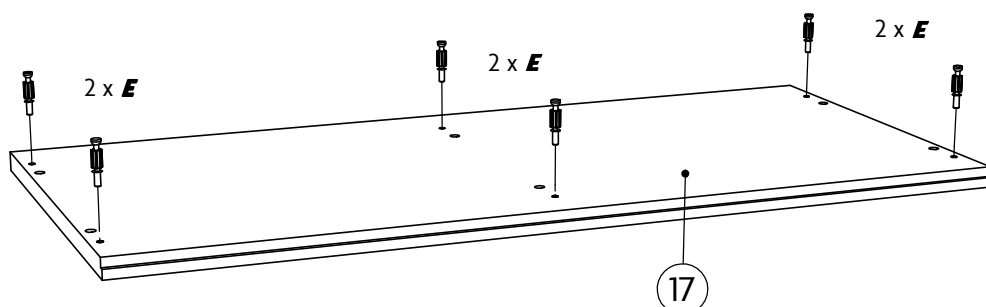

E x 12

ETAPE 21

Ø 8 x 30mm

**C** x 4

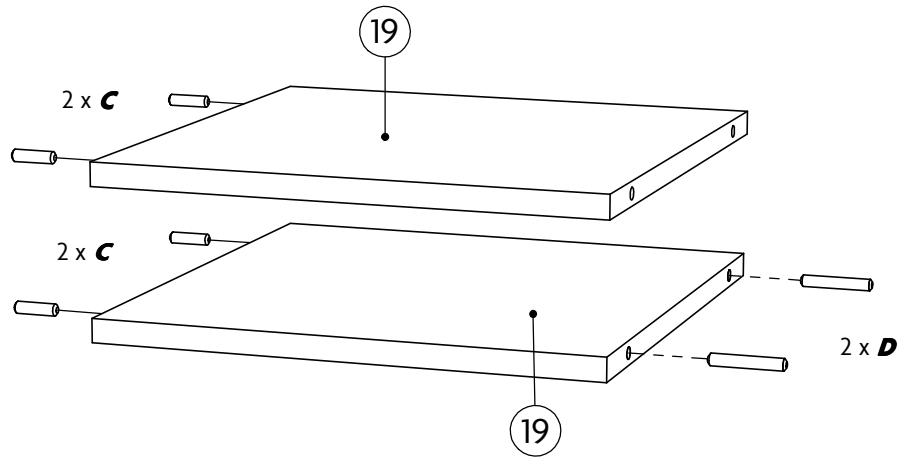
Ø 8 x 50mm

**D** x 2

ETAPE 22

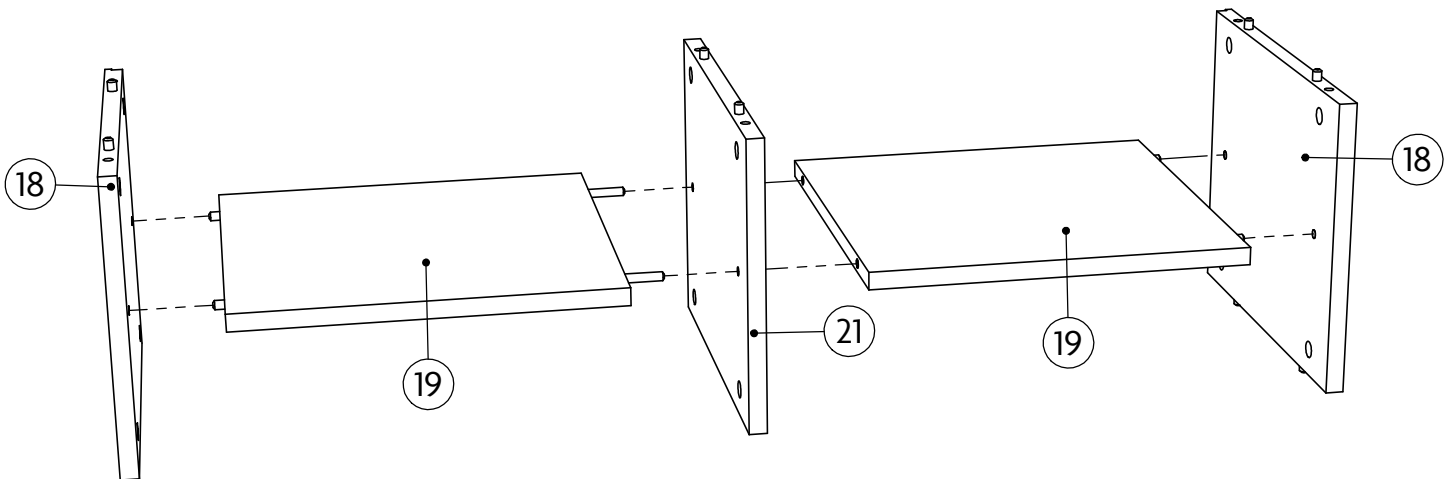

ETAPE 23

Ø 15mm

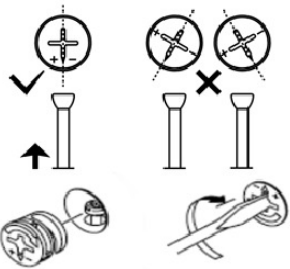
**F** x 12

Avant de raccorder les excentriques, bien s'assurer que la position de départ est correcte avant d'insérer le boulon de connection.

Puis tourner dans le sens horaire jusqu'à la butée.

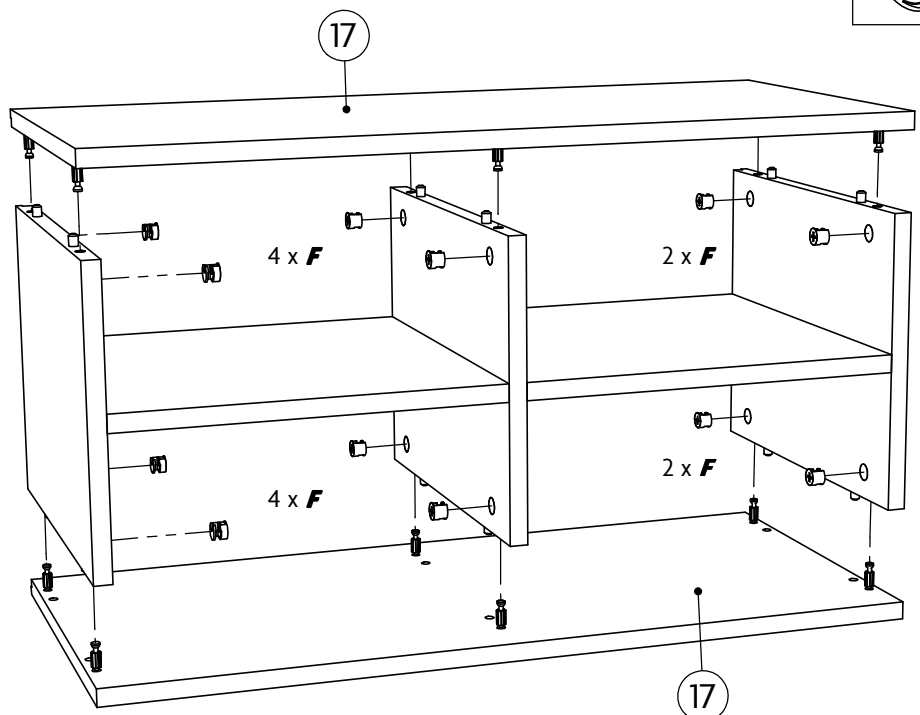

ETAPE 24

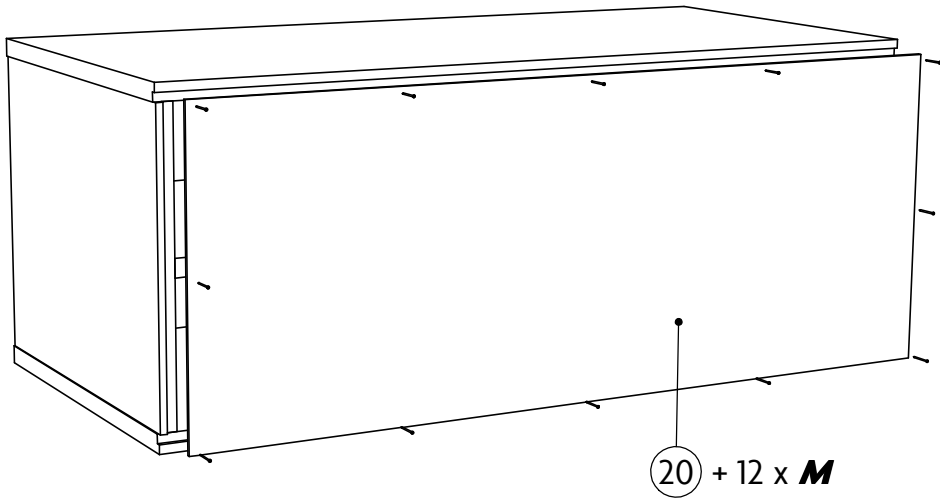
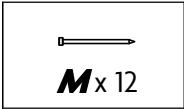

ETAPE 25

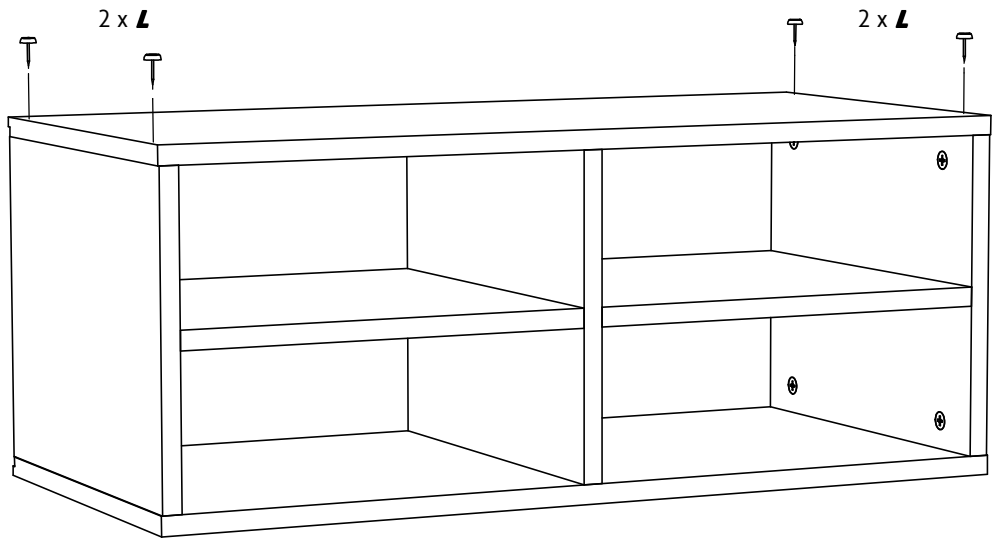
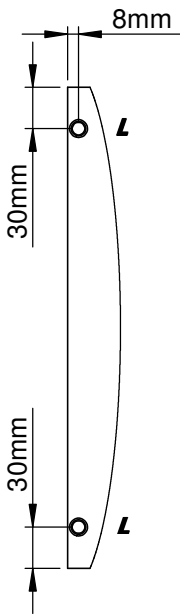
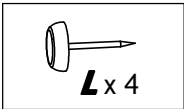

ETAPE 26

x8

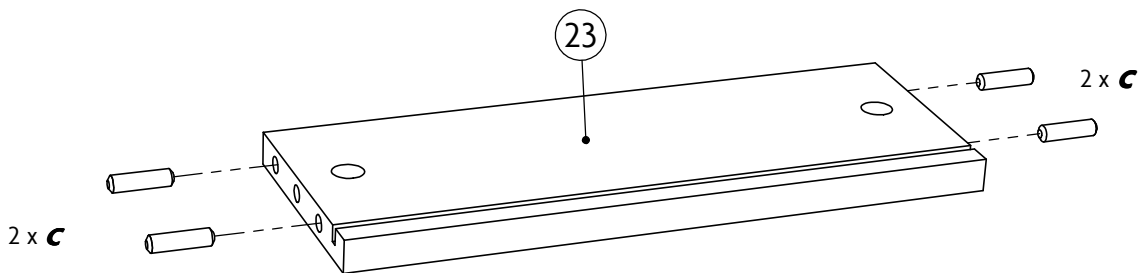
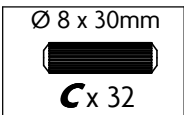

ETAPE 27

x4

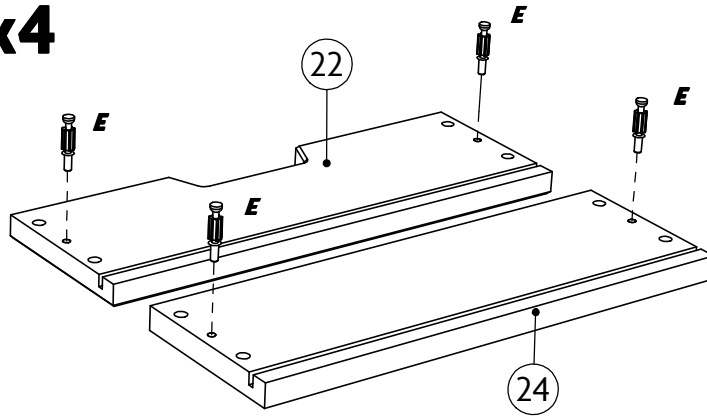

L=35mm
E x 16

ETAPE 28

x4

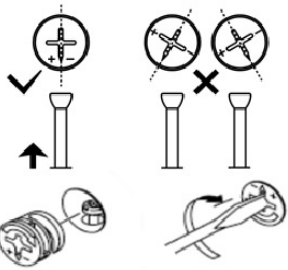

Avant de raccorder les excentriques, bien s'assurer que la position de départ est correcte avant d'insérer le boulon de connection.

Puis tourner dans le sens horaire jusqu'à la butée.

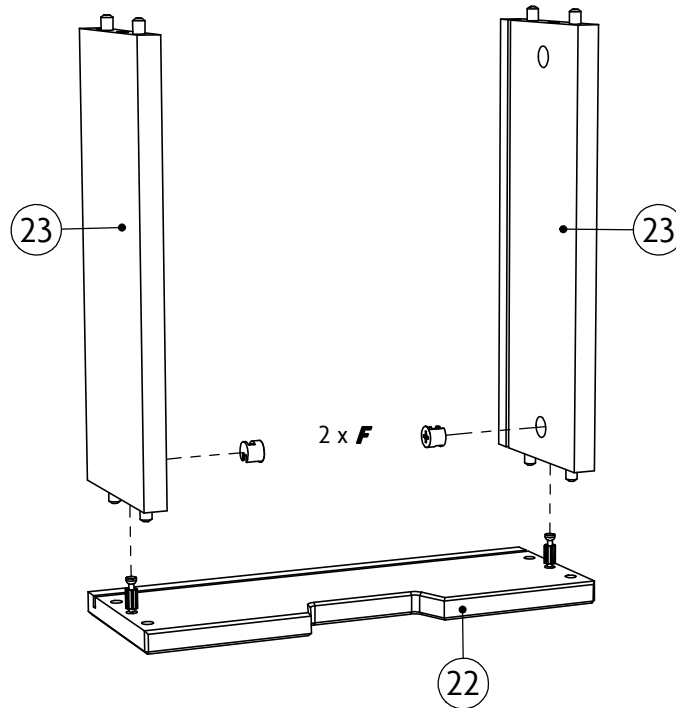

Ø 15mm
F x 8

ETAPE 29

x4

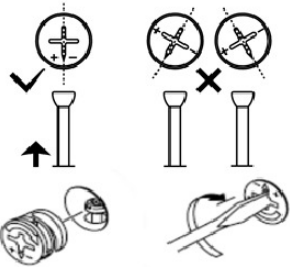

Avant de raccorder les excentriques, bien s'assurer que la position de départ est correcte avant d'insérer le boulon de connection.

Puis tourner dans le sens horaire jusqu'à la butée.

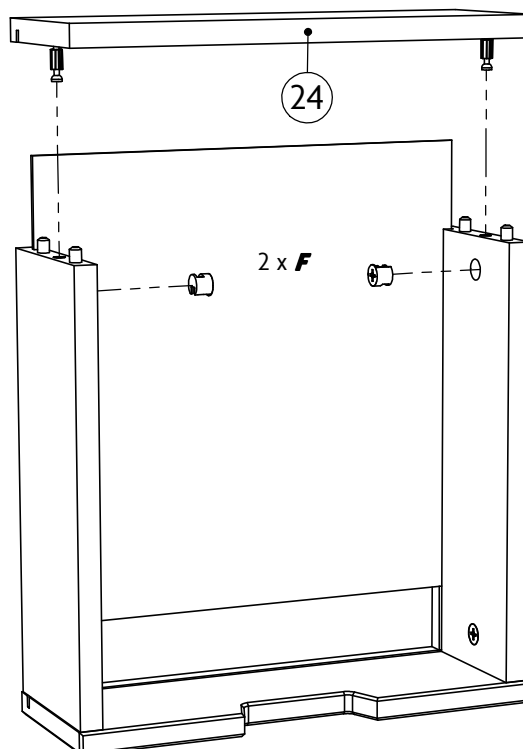

Ø 15mm
F x 8

ETAPE 30

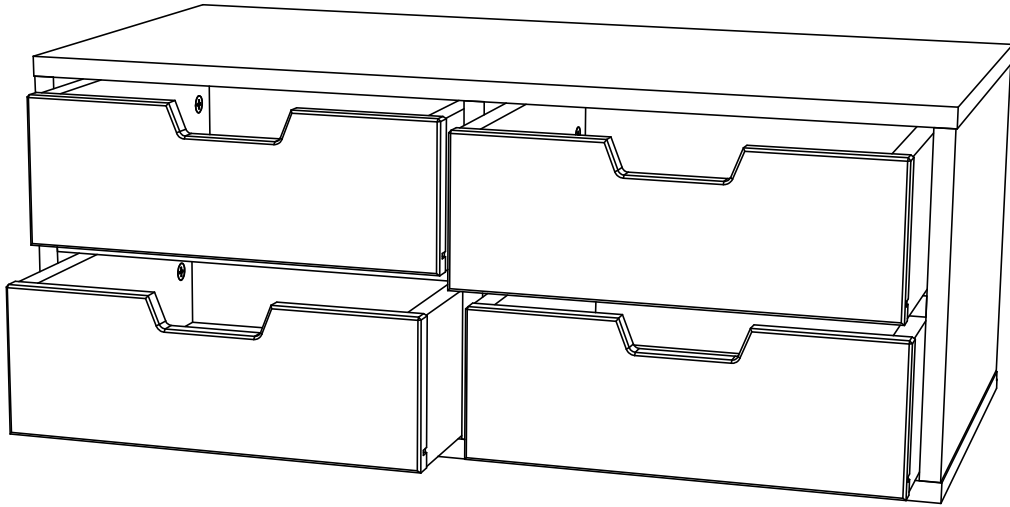

ETAPE 31

