



1H30 min



Votre meuble se recycle.  
Renseignez-vous auprès de  
votre centre de tri.

**WEBER INDUSTRIES**

67580 MERTWILLER

**FAB. 767**

MOD.: **2138/xx**



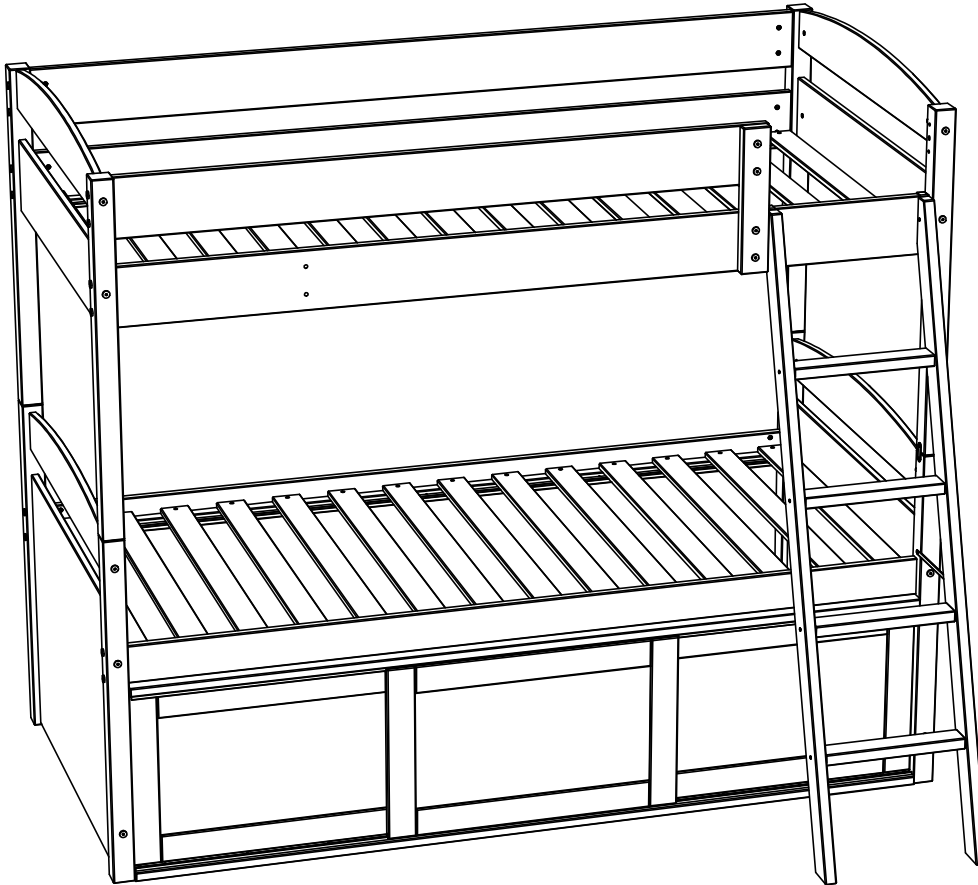







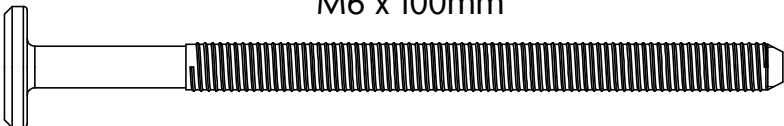
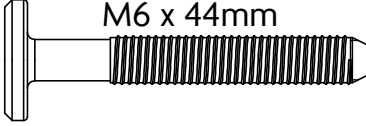
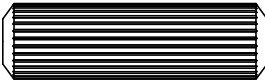

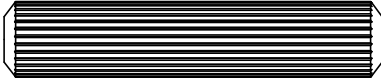
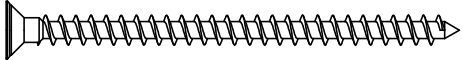
LOT.: **XXXXSXX**

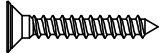
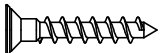
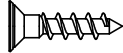

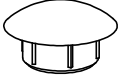
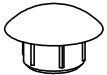
- \* Le couchage en hauteur ne convient pas à un enfant de moins de 6 ans, en raison des risques de blessures dues aux chutes.
- \* Lit conforme aux exigences de sécurité NF EN 747 -1&2 +A1 2015.
- \* Les sommiers font partie intégrante et indissociable du lit.
- \* Pour effectuer un montage conforme, il est impératif de se reporter à la notice de montage et aux instructions.
- \* Notices et instructions à lire et à conserver pour utilisation ultérieure.
- \* The sleeping in height is not convenient for a child of less than 6 years, because of the risk of injury from falls.
- \* Bed corresponding to the requirements of safety NF EN 747 -1&2 +A1 2015.
- \* Slats are an integral and inseparable part of the bed.
- \* To make a conform assembly, it is imperative to refer to the assembly instruction and to the instructions.
- \* Assembly instruction and instructions to be read and to be preserved for later use.
- \* Das Oberbett ist nicht geeignet für Kind unter 6 Jahren, wegen der Gefahr von Verletzungen durch Stürze.
- \* Das Bett entspricht den Sicherheitsvorschriften NF EN 747 -1&2 +A1 2015.
- \* Die Lattenroste bilden ein Gesamt mit den Betten und können nicht davon getrennt werden.
- \* Um eine tadellose Montage durchzuführen, ist es wichtig, sich auf die Aufbauanleitung und auf die Anweisungen zu beziehen.
- \* Aufbauanleitung und Anweisungen, sind zu lesen und für spätere Zwecke aufzubewahren.

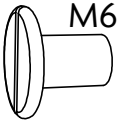

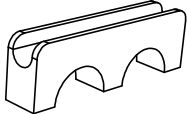
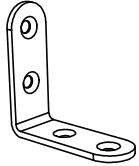
1 / 2

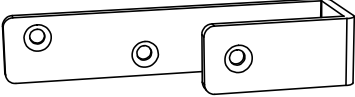
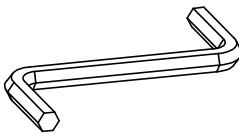
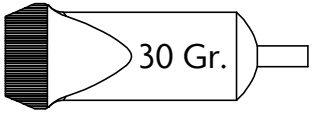
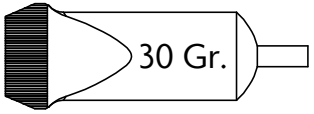
 <p>M6 x 100mm</p>		 <p>M6 x 44mm</p>	
<b>A</b>	<b>42</b>	<b>B</b>	<b>4</b>
 <p>Ø 10 x 35mm</p>		 <p>Ø 8 x 40mm</p>	
<b>C</b>	<b>55</b>	<b>D</b>	<b>16</b>
 <p>Ø 10 x 50mm</p>		 <p>Ø 4 x 60 mm</p>	
<b>E</b>	<b>4</b>	<b>F</b>	<b>8</b>
 <p>Ø 8 x 40mm</p>		 <p>Ø 4x40mm</p>	
<b>G</b>	<b>4</b>	<b>H</b>	<b>56/60</b>
 <p>Ø 3 x 20 mm</p>		 <p>Ø 3,5 x 20 mm</p>	
<b>I</b>	<b>2</b>	<b>J</b>	<b>16</b>
 <p>Ø 3,5 x 15 mm</p>		 <p>Ø 3 x 13 mm</p>	
<b>K</b>	<b>4</b>	<b>L</b>	<b>18</b>
 <p>Ø 10 mm</p>		 <p>Ø 8mm</p>	
<b>M</b>	<b>1</b>	<b>N</b>	<b>4</b>
 <p>Ø 7 mm</p>		 <p>M6</p>	
<b>O</b>	<b>4</b>	<b>P</b>	<b>42</b>
 <p>M6</p>			
<b>Q</b>	<b>4</b>	<b>R</b>	<b>4</b>
			
<b>S</b>	<b>6</b>	<b>T</b>	<b>2</b>
 <p>L = 260mm</p>			
<b>U</b>		<b>1</b>	
 <p>100 x 28 x 45mm</p>			
<b>V</b>	<b>2</b>	<b>W</b>	<b>1</b>
 <p>30 Gr.</p>		 <p>30 Gr.</p>	
<b>X</b>	<b>1</b>	<b>X</b>	<b>1</b>

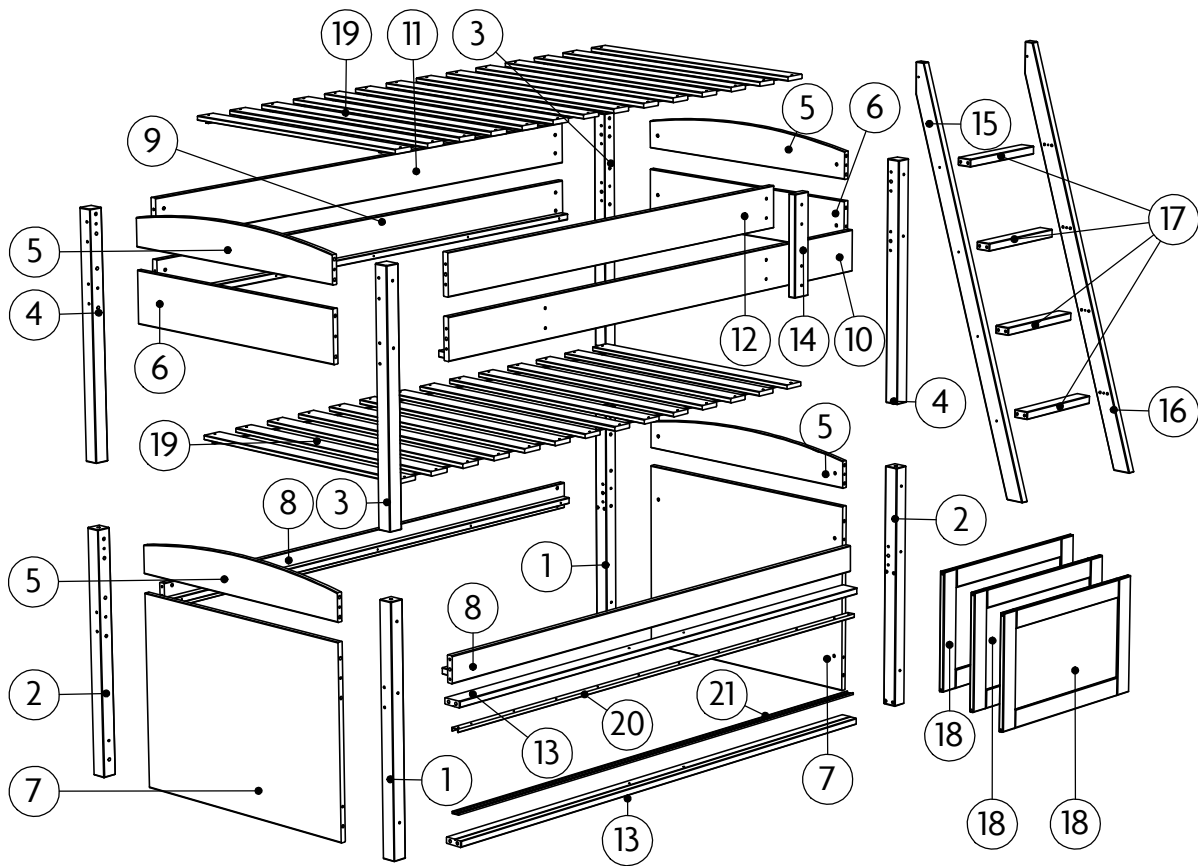

N° PIECE	QTE	Longueur	Largeur	Colis
1	2	831	50	1/2
2	2	831	50	1/2
3	2	831	50	1/2
4	2	831	50	1/2
5	4	890	136	1/2
6	2	890	175	1/2
7	2	890	650	1/2
8	2	1890 / 1990	90	2/2
9	1	1890 / 1990	140	2/2
10	1	1890 / 1990	140	2/2
11	1	1890 / 1990	140	2/2
12	1	1500 / 1600	140	2/2
13	2	1890 / 1990	65	2/2
14	1	342	65	1/2
15	1	1533	65	2/2
16	1	1533	65	2/2
17	4	340	55	2/2
18	3	700	423	1/2
19	2	14 / 15 lattes	895	2/2
20	1	1885	28	2/2
21	1	1885	28	2/2

**ETAPE 1**

**x4**

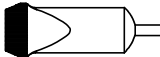
$\varnothing 8 \times 40\text{mm}$  <b>D</b> x 16	 <b>X</b>
--	---

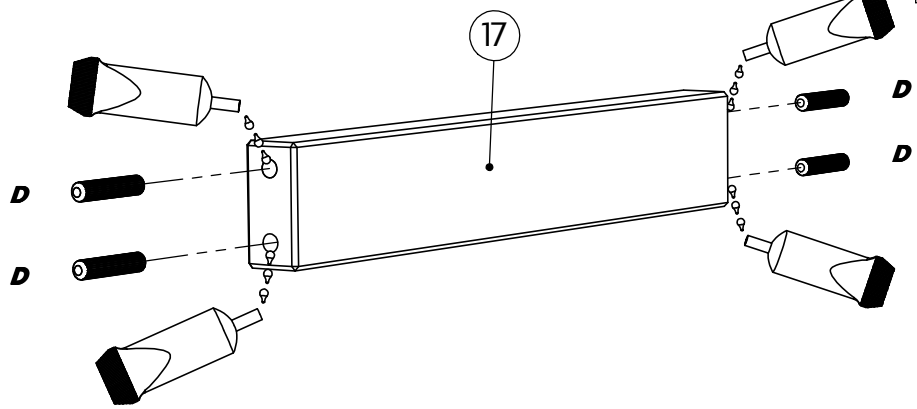

**ETAPE 2**

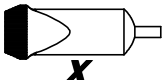
 <b>X</b>
---

**ETAPE 3**

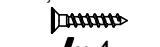
$\varnothing 4 \times 60\text{mm}$  <b>F</b> x 8	$\varnothing 3,5 \times 20\text{mm}$  <b>J</b> x 4
---	---

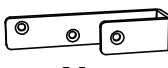
 <b>V</b> x 2
---

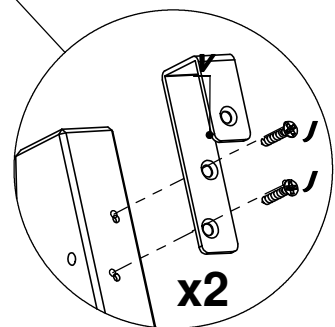
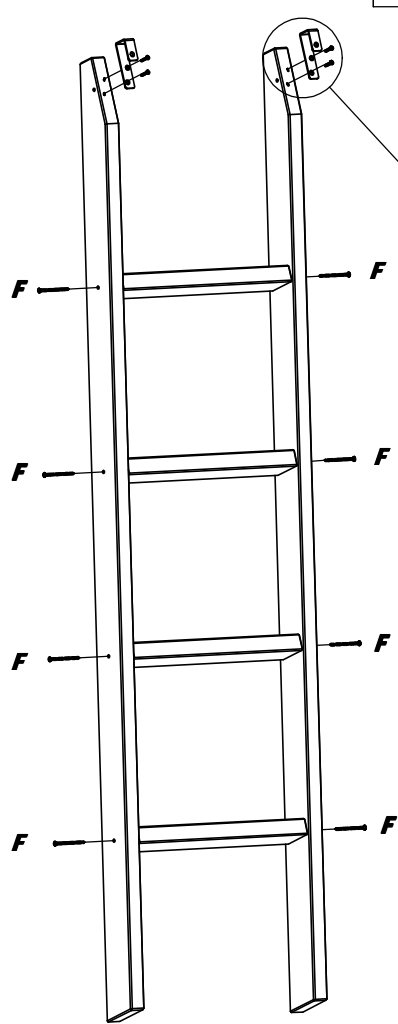
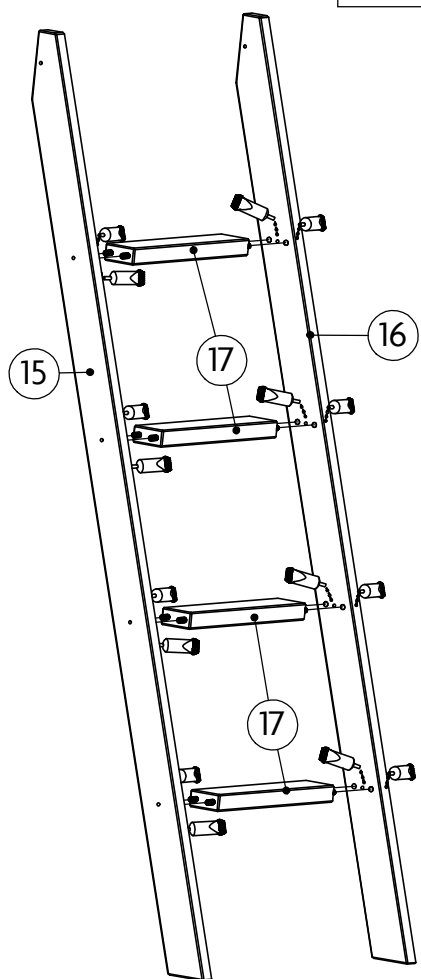

**ETAPE 4**

**x3**

 <b>S</b> x 6
---

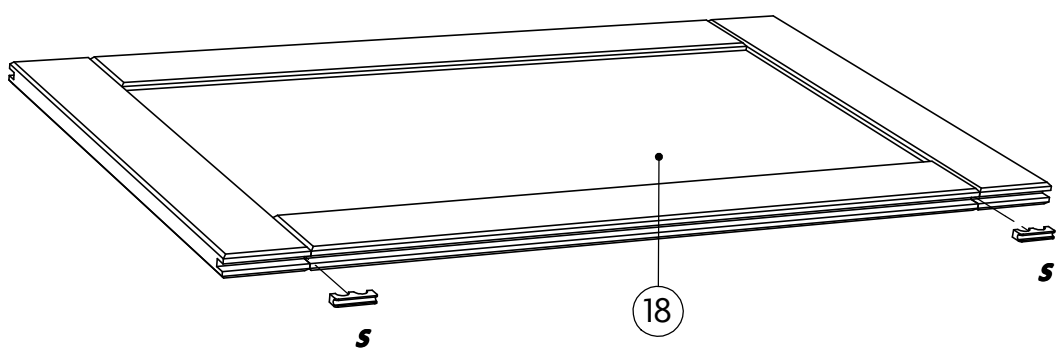

**ETAPE 5**

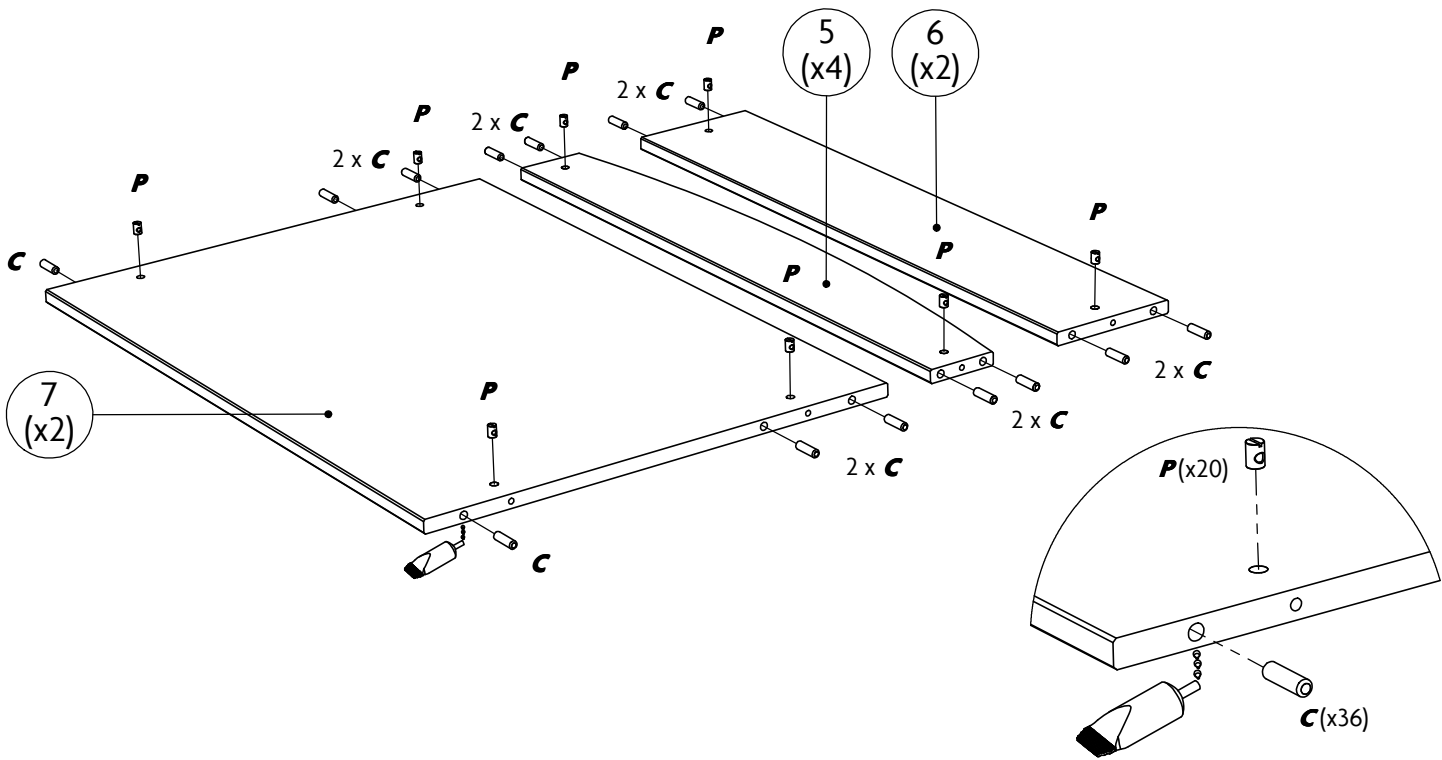
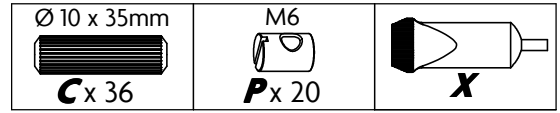

**ETAPE 6**

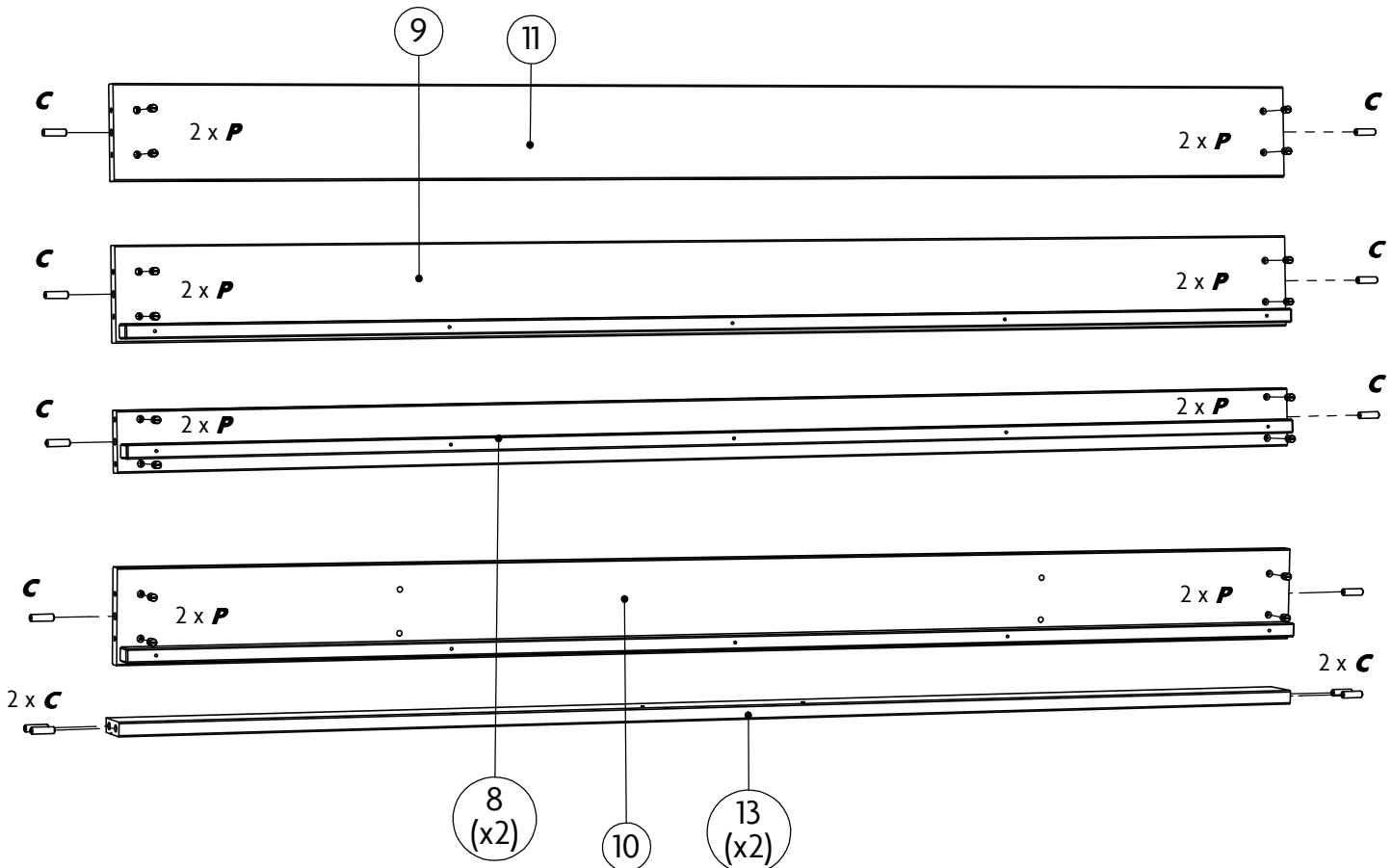
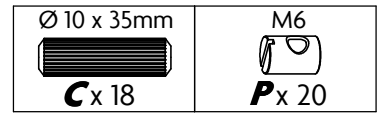

**ETAPE 7**

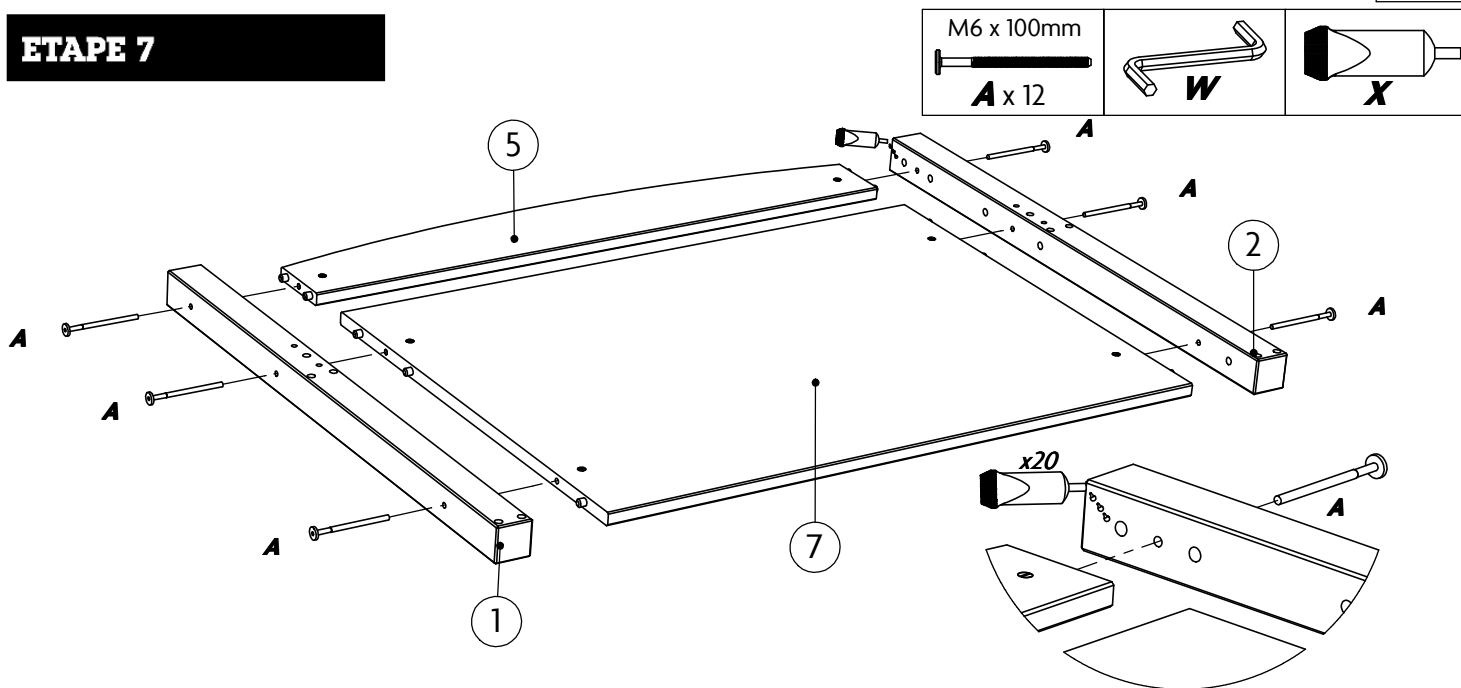

**ETAPE 8**

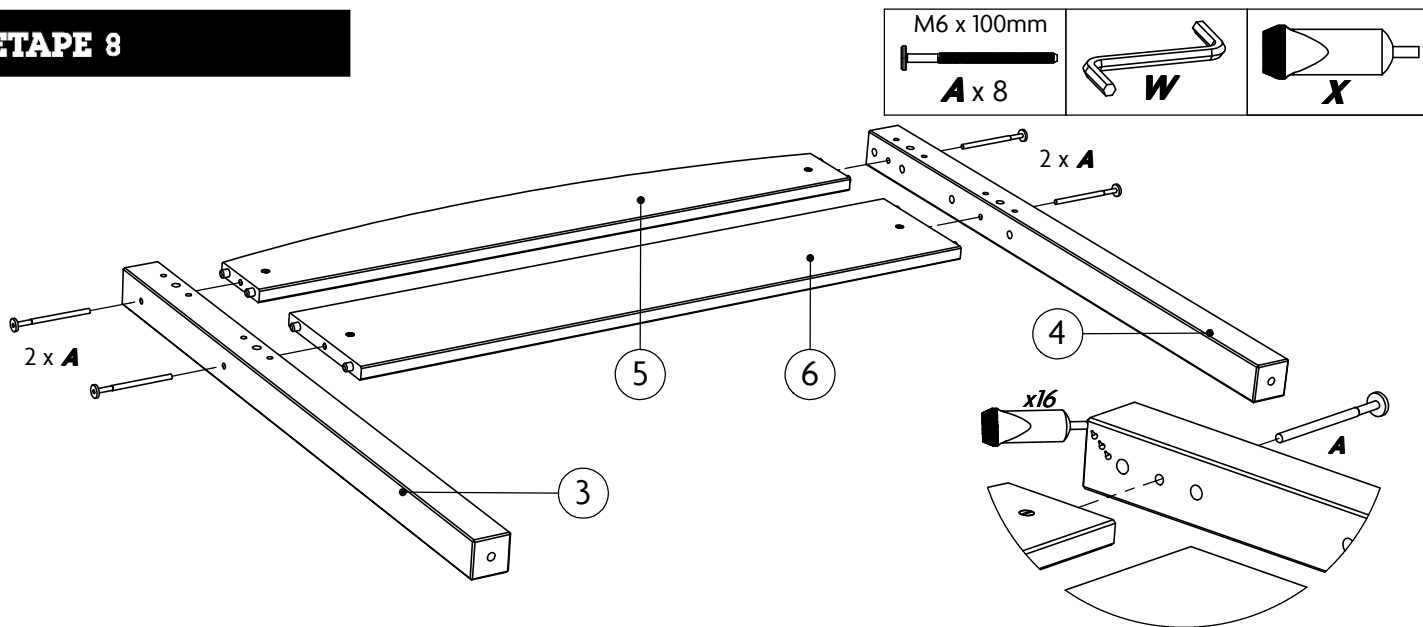

**ETAPE 9**

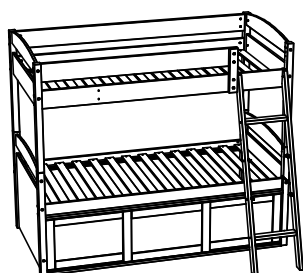
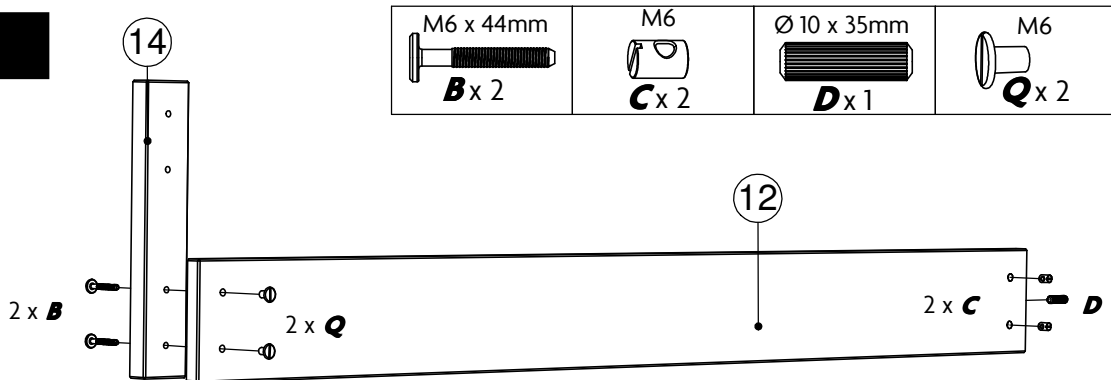

## ETAPE 10

M6 x 100mm

**A** x 8

Ø 10 x 50mm

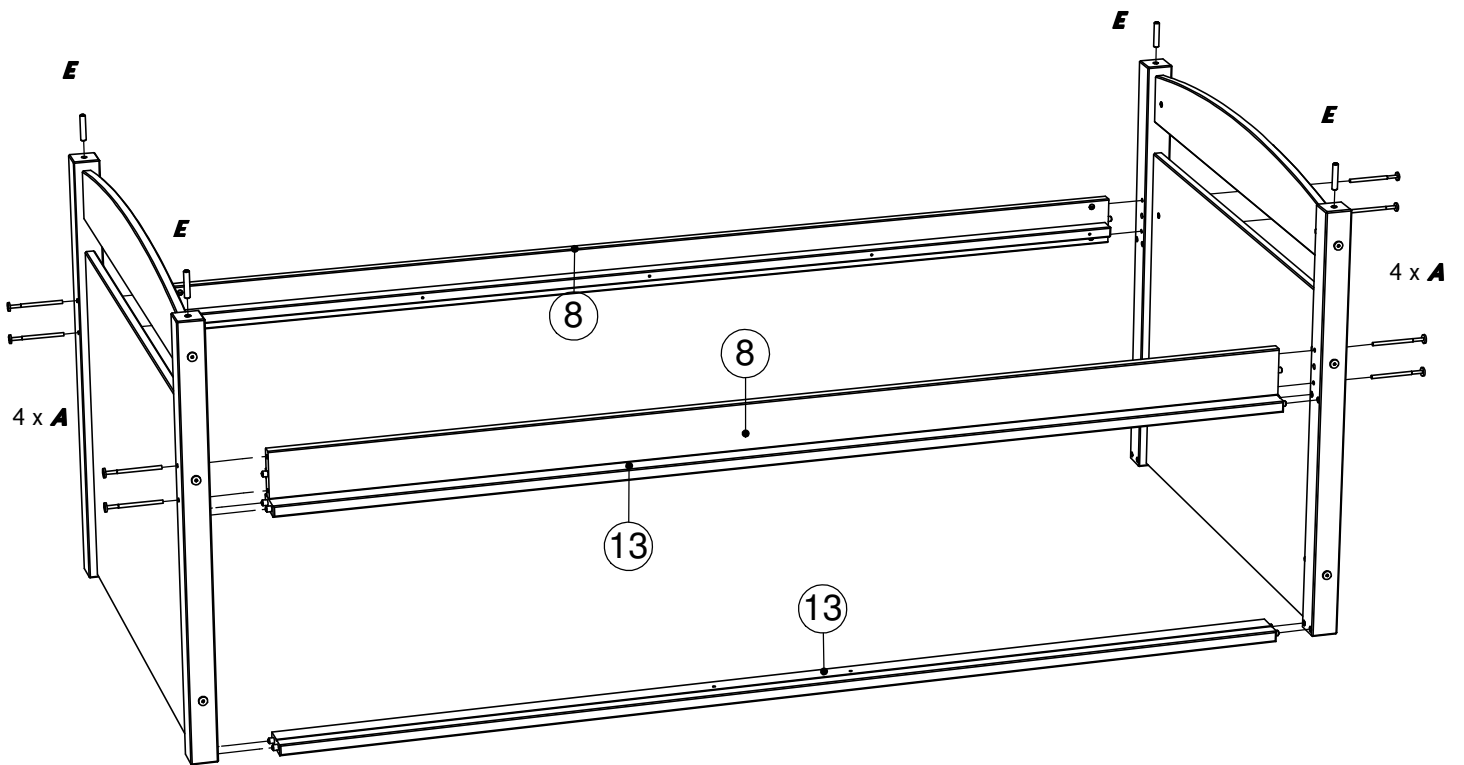
**E** x 4**W**

## ETAPE 11

Ø 4 x 40 mm

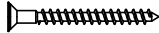
**G** x 2

Ø 4,5 x 30 mm

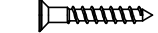
**H** x 28/30

Ø 3,5 x 20 mm

**J** x 2

Ø 3,5 x 15 mm

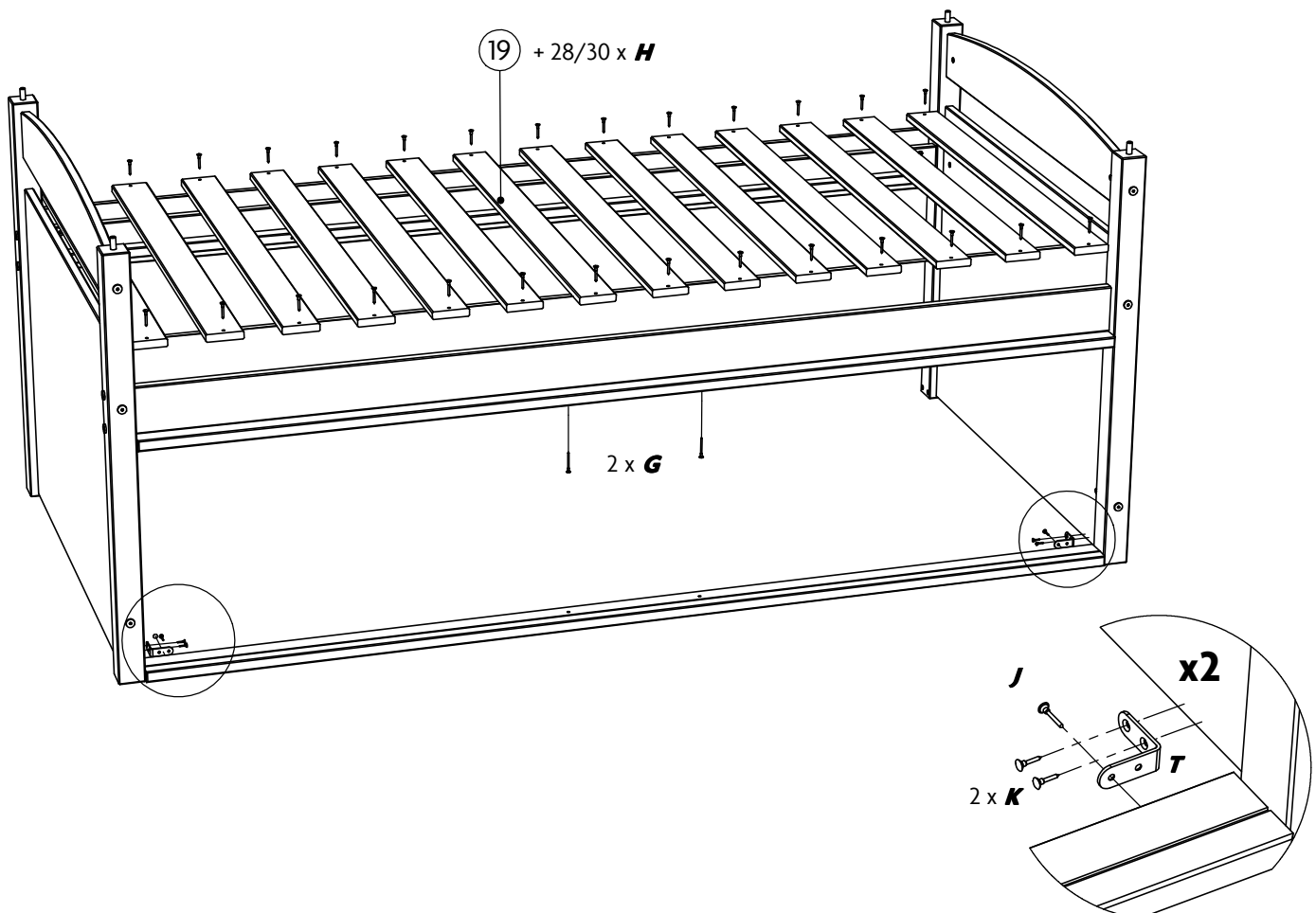
**K** x 4**T** x 2

## ETAPE 12

Ø 3 x 13 mm



L x 18

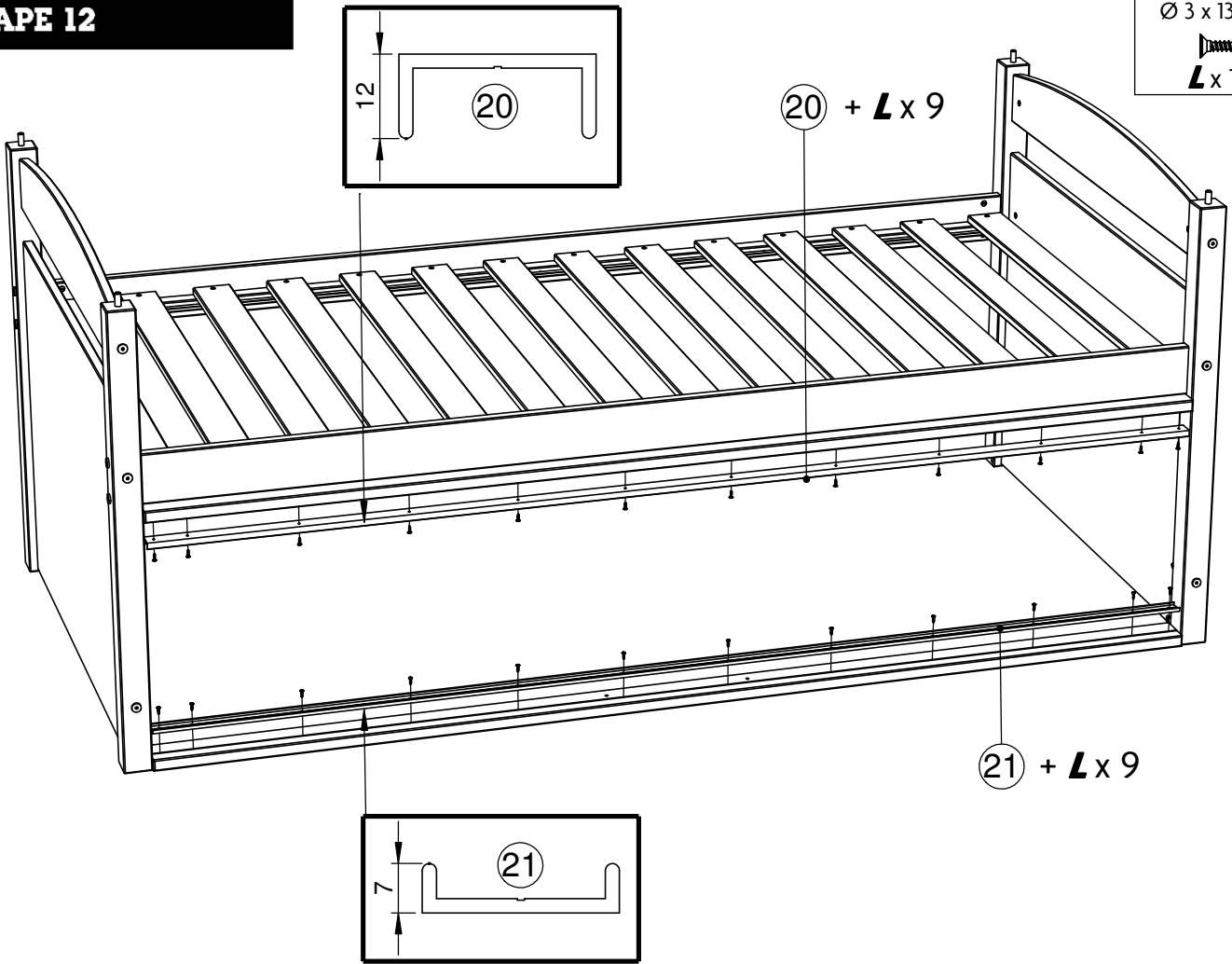

## ETAPE 13

M6 x 100mm



A x 12





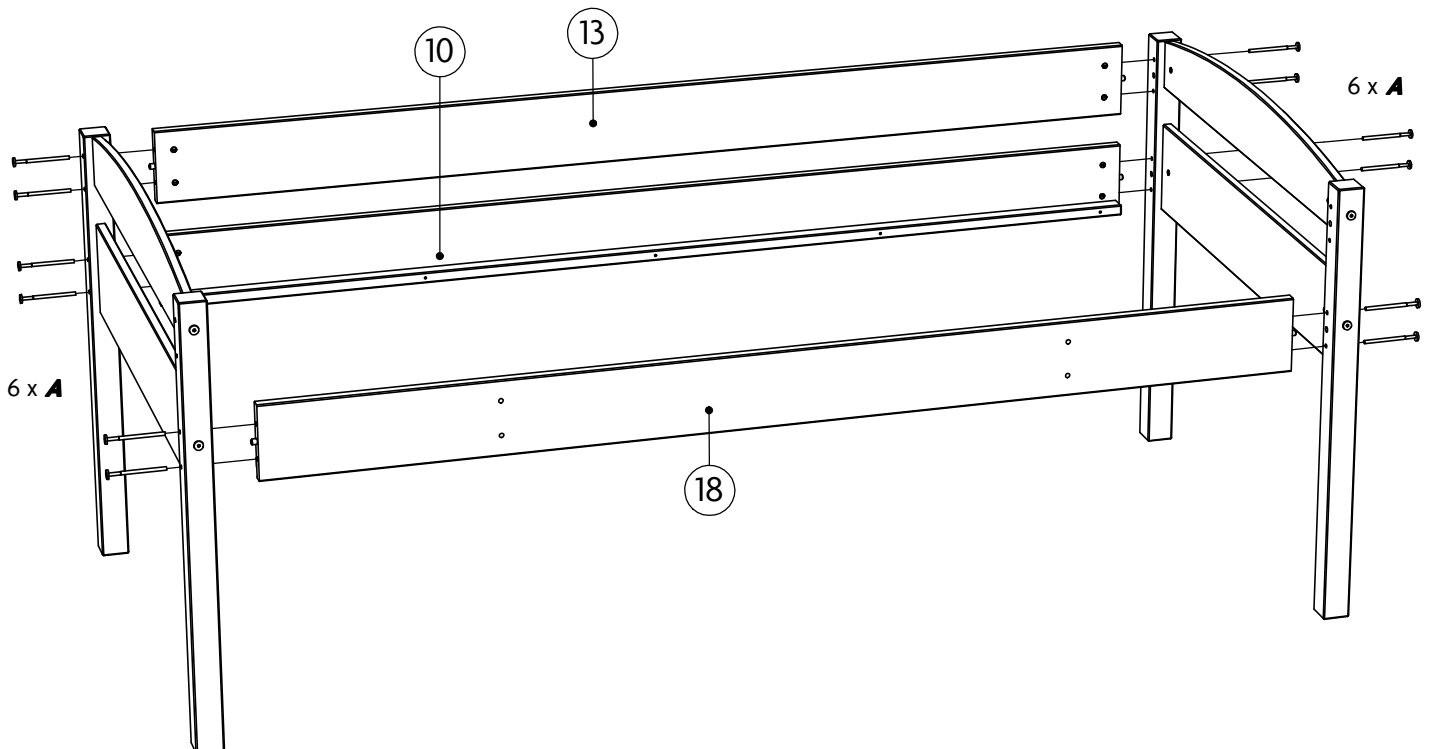

W





**ETAPE 14**

M6 x 100mm  <b>A x 2</b>	M6 x 44mm  <b>B x 2</b>	Ø 8mm  <b>N x 4</b>	M6  <b>Q x 2</b>	 <b>W</b>
---	--	--	---	---

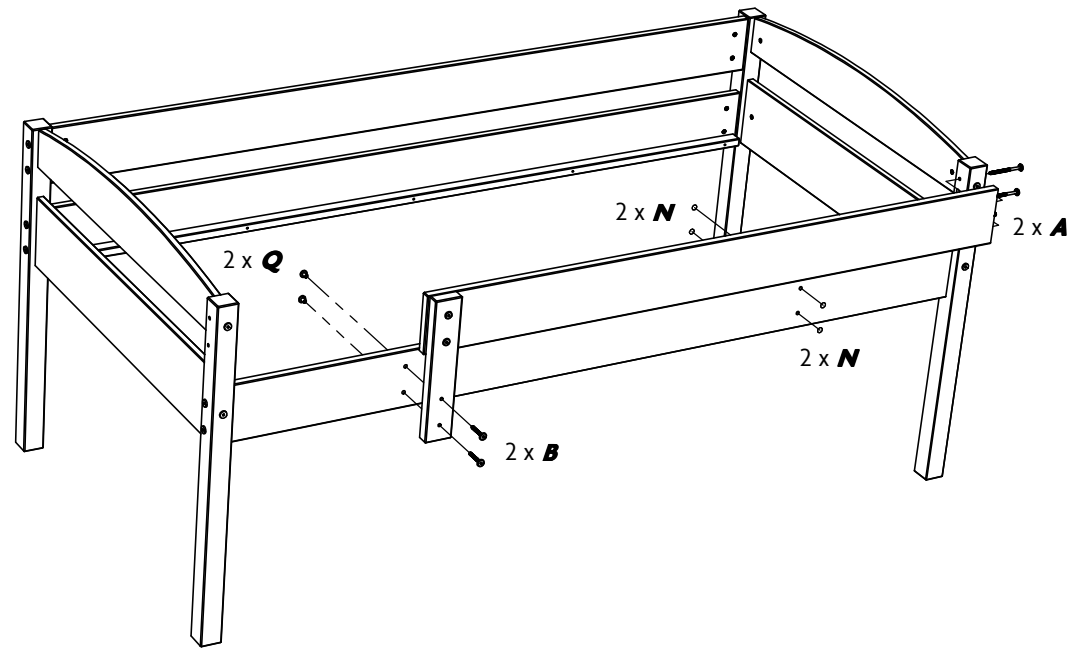
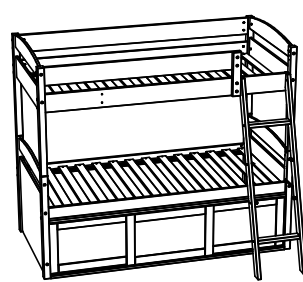
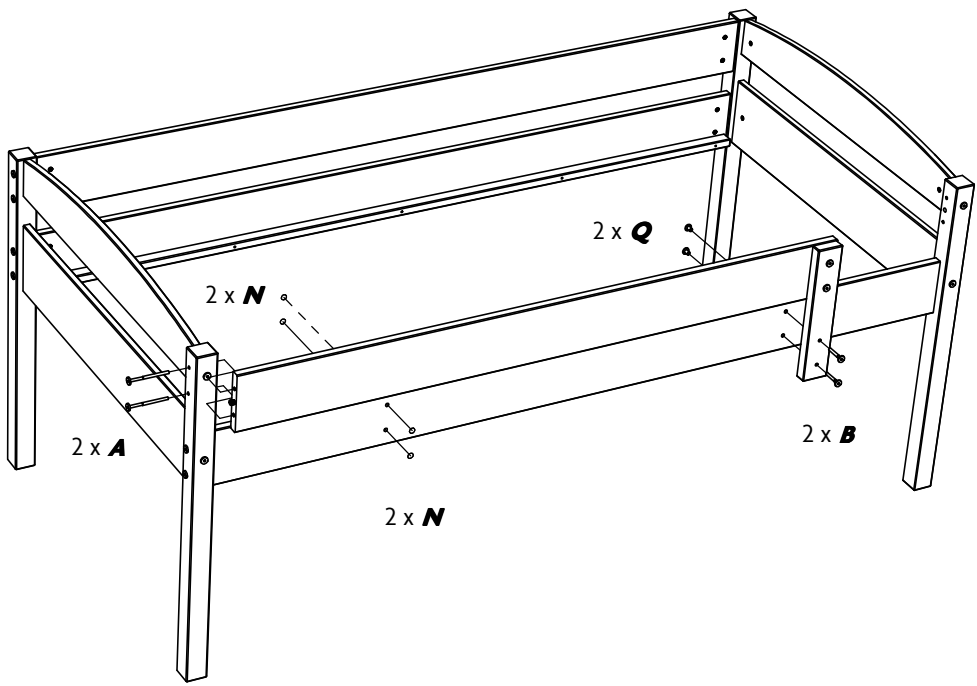
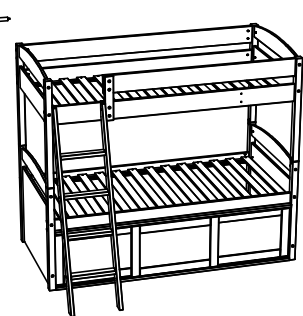

**ETAPE 15**

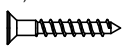
Ø 4,5 x 30 mm  <b>H x 28/30</b>
--

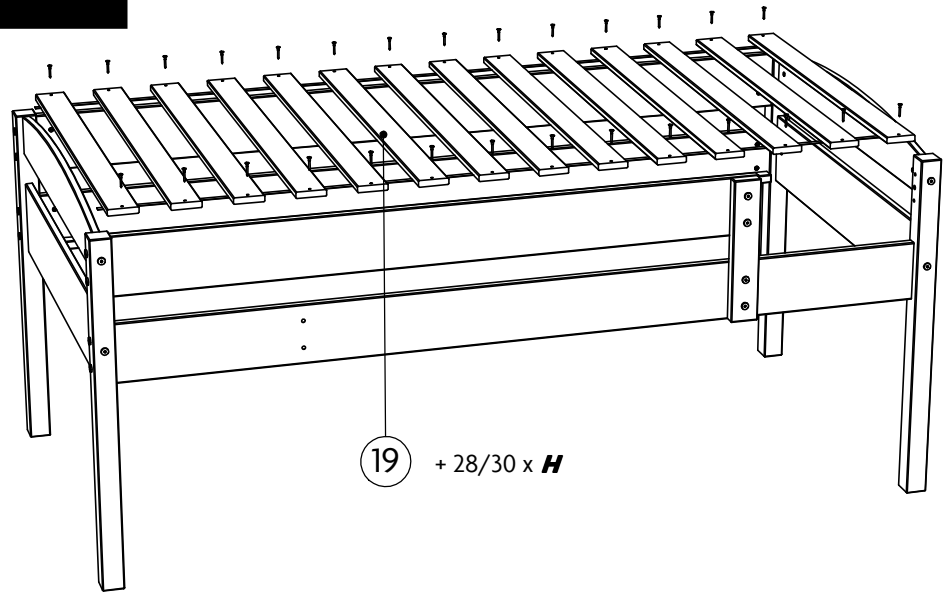

ETAPE 16

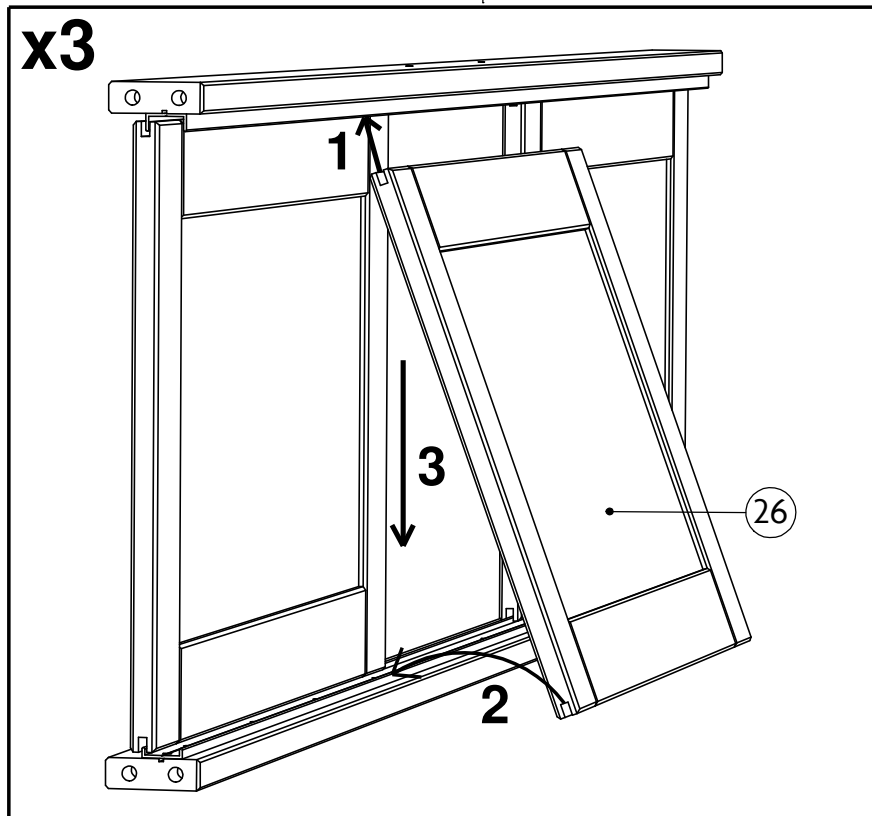
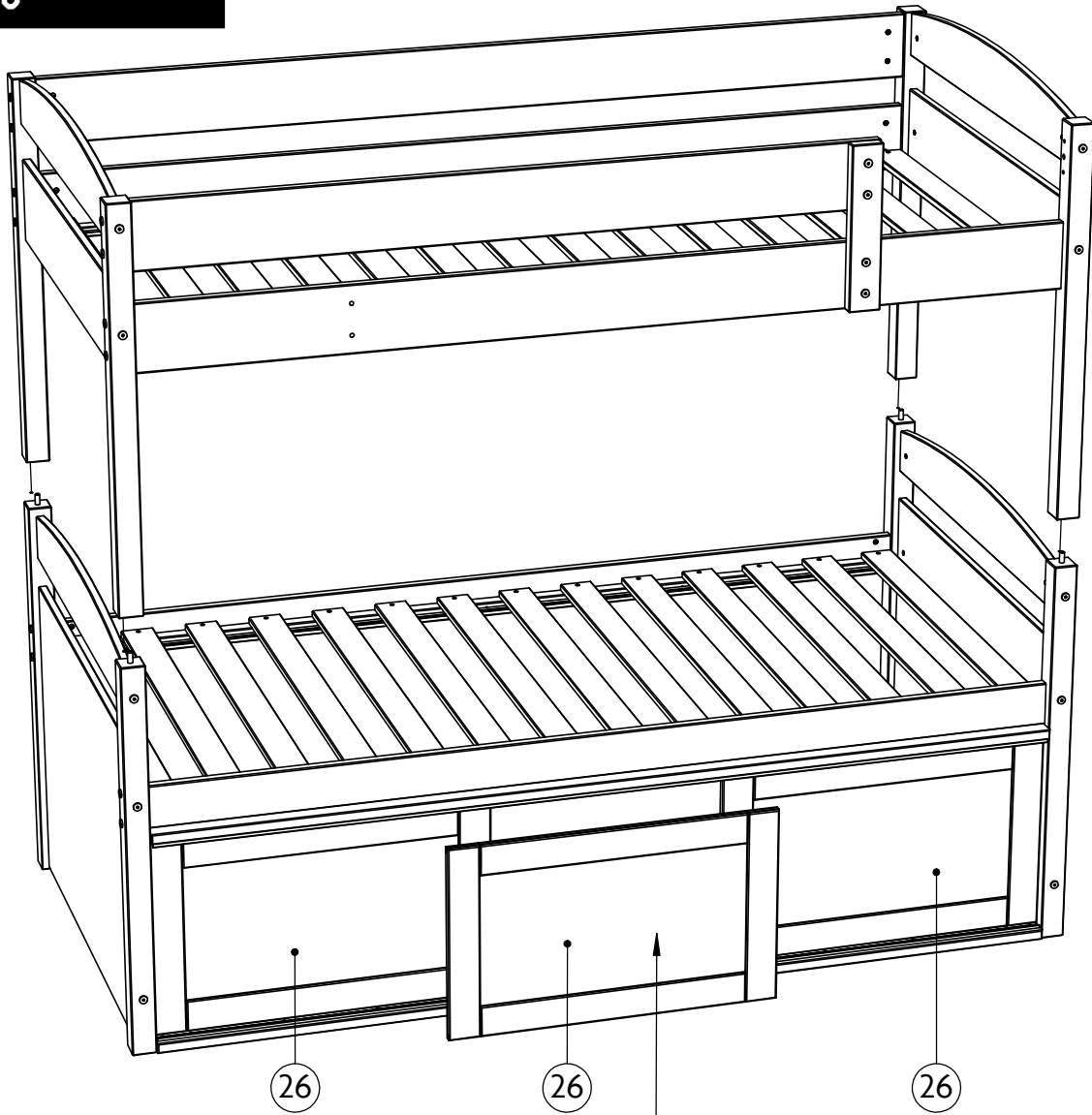



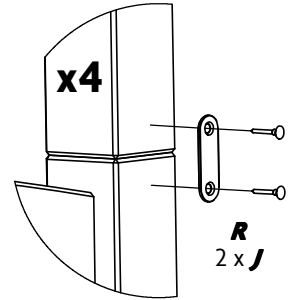
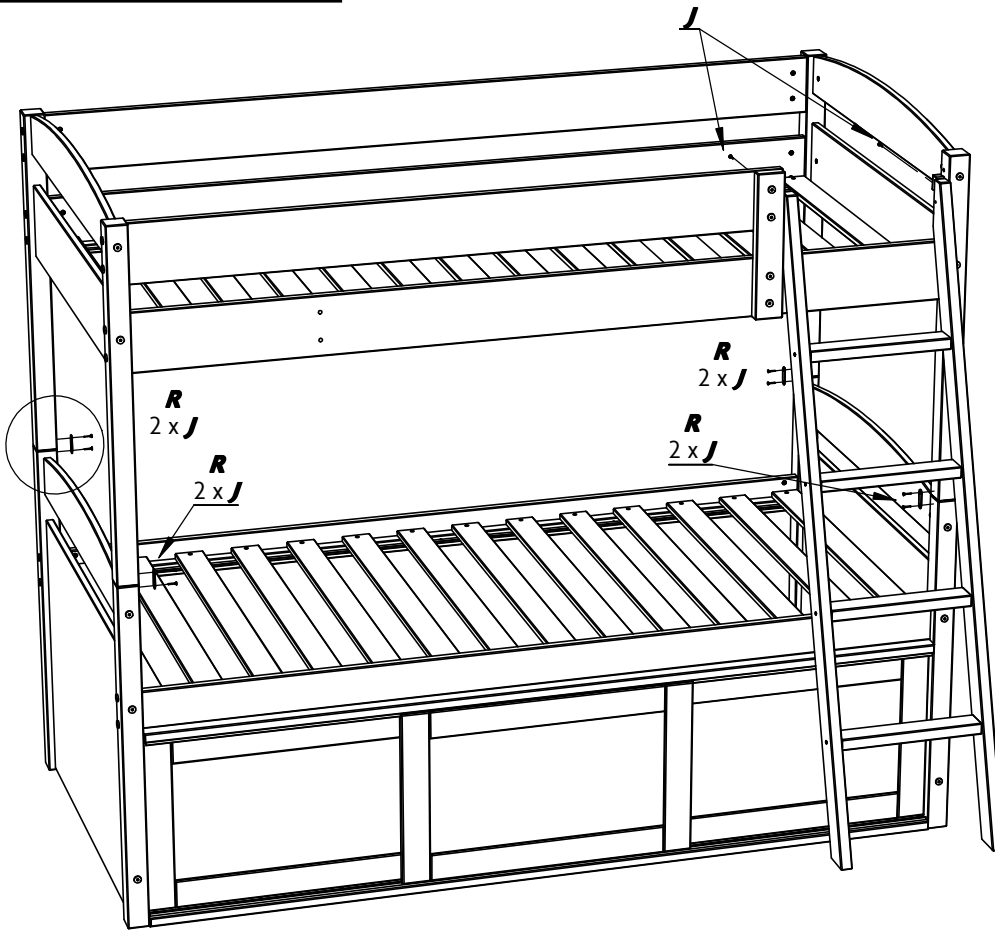

**ETAPE 17**

$\varnothing 3,5 \times 20 \text{ mm}$  <b>J</b> x 10	 <b>R</b> x 4
--	---

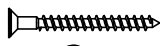

**ETAPE 18**

$\varnothing 4 \times 40 \text{ mm}$  <b>G</b> x 2	$\varnothing 3 \times 20 \text{ mm}$  <b>I</b> x 2	$\varnothing 10 \text{ mm}$  <b>M</b> x 1	$\varnothing 7 \text{ mm}$  <b>O</b> x 4	$L = 260 \text{ mm}$  <b>U</b> x 1
---	---	--	---	---

