



60 min



Votre meuble se recycle.
Renseignez-vous auprès de
votre centre de tri.

WEBER INDUSTRIES

67580 MERTWILLER

FAB. 767

MOD.: 2400/xx

LOT.: XXXXSXX

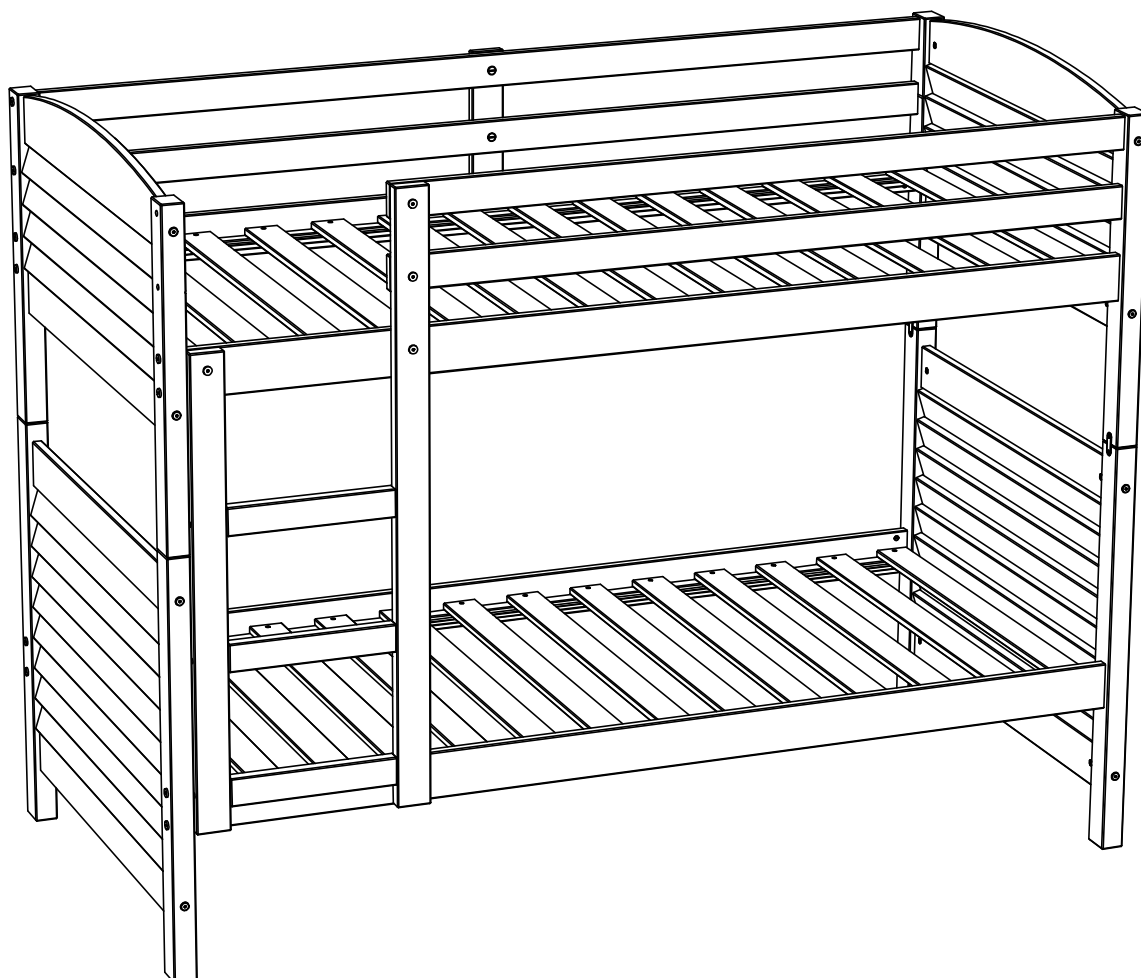







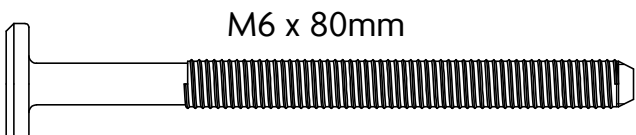
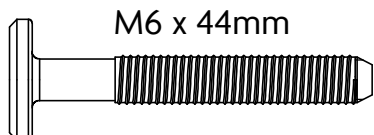
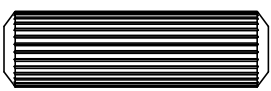
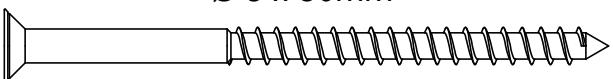
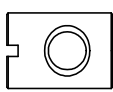

- * Le couchage en hauteur ne convient pas à un enfant de moins de 6 ans, en raison des risques de blessures dues aux chutes.
- * Lit conforme aux exigences de sécurité NF EN 747 -1&2 +A1 2015.
- * Les sommiers font partie intégrante et indissociable du lit.
- * Pour effectuer un montage conforme, il est impératif de se reporter à la notice de montage et aux instructions.
- * Notices et instructions à lire et à conserver pour utilisation ultérieure.

- * The sleeping in height is not convenient for a child of less than 6 years, because of the risk of injury from falls.
- * Bed corresponding to the requirements of safety NF EN 747 -1&2 +A1 2015.
- * Slats are an integral and inseparable part of the bed.
- * To make a conform assembly, it is imperative to refer to the assembly instruction and to the instructions.
- * Assembly instruction and instructions to be read and to be preserved for later use.

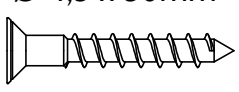
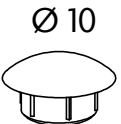
- * Das Oberbett ist nicht geeignet für Kind unter 6 Jahren, wegen der Gefahr von Verletzungen durch Stürze.
- * Das Bett entspricht den Sicherheitsvorschriften NF EN 747 -1&2 +A1 2015.
- * Die Lattenroste bilden ein Gesamt mit den Betten und können nicht davon getrennt werden.
- * Um eine tadellose Montage durchzuführen, ist es wichtig, sich auf die Aufbauanleitung und auf die Anweisungen zu beziehen.
- * Aufbauanleitung und Anweisungen, sind zu lesen und für spätere Zwecke aufzubewahren.

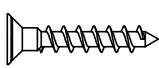
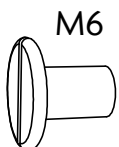
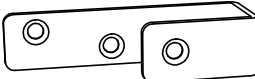
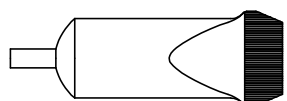

Colis 2 / 2

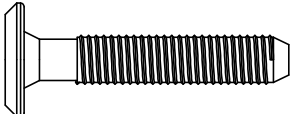
 <p>M6 x 80mm</p>		 <p>M6 x 44mm</p>	
A	22	B	4
 <p>Ø 10 x 35mm</p>		 <p>Ø 5 x 80mm</p>	
C	14	D	6
 <p>M6</p>		 <p>Ø 10 x 50mm</p>	
E	22	F	4
		 <p>Ø 4,5 x 30mm</p>	
		G	56 / 60
 <p>Ø 10</p>		 <p>Ø 7</p>	
H	2	I	4
			
		J	4
 <p>Ø 8 x 40mm</p>		 <p>Ø 3,5 x 20mm</p>	
K	12	M	14
 <p>M6</p>			
N	7	O	2
			
P	1	Q	1
 <p>M6 x 35mm</p>			
R	3		

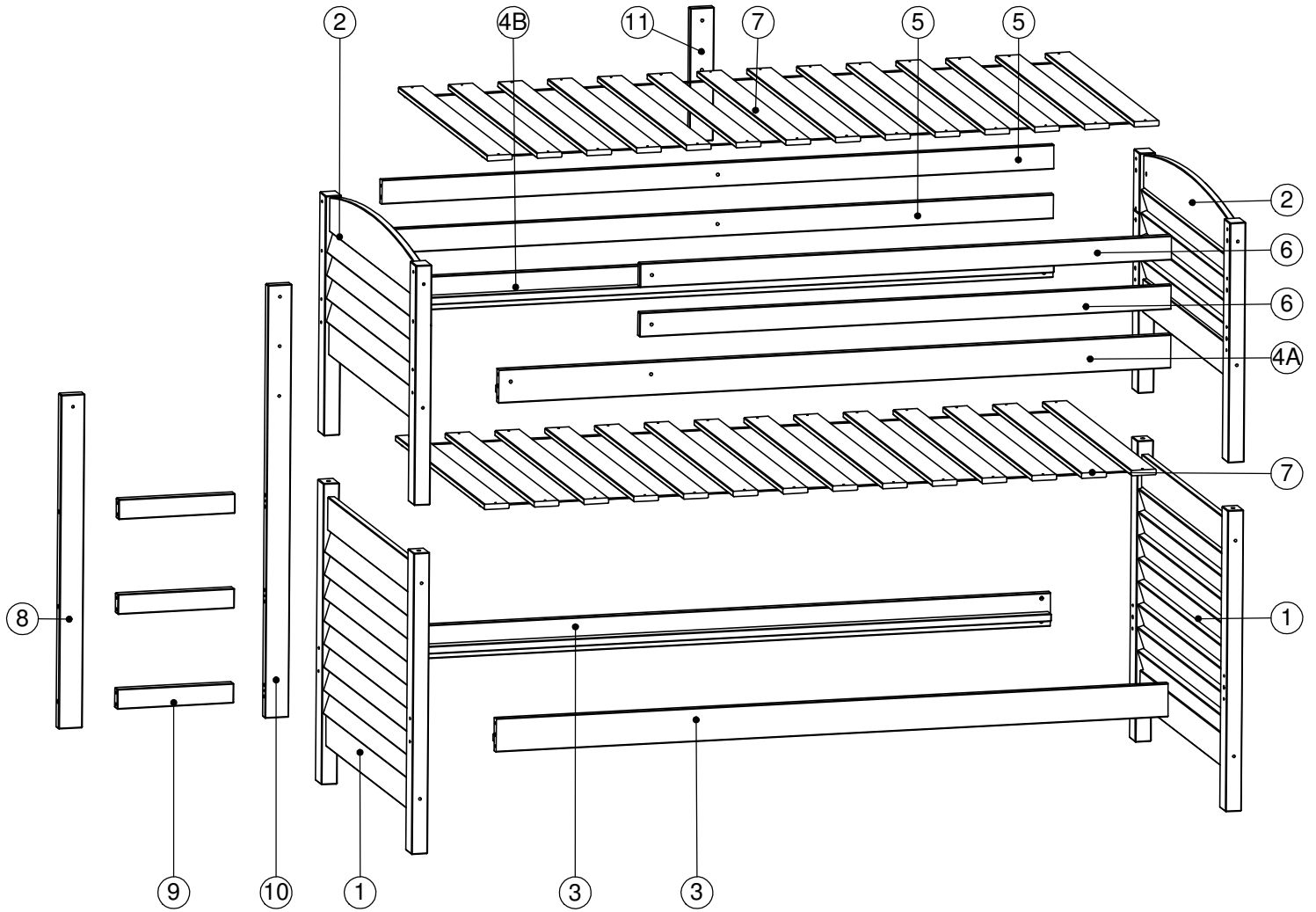

N° PIECE	QTE	Longueur	Largeur	Colis
1	2	970	835	1/2
2	2	970	701,50	1/2
3	2	1890	93	2/2
4A	1	1890	93	2/2
4B	1	1890	93	2/2
5	2	1890	67	2/2
6	2	1495	67	2/2
7	2	1890	895	2/2
8	1	926	67	2/2
9	3	328	55	2/2
10	1	1200	67	2/2
11	1	370	67	2/2

1.

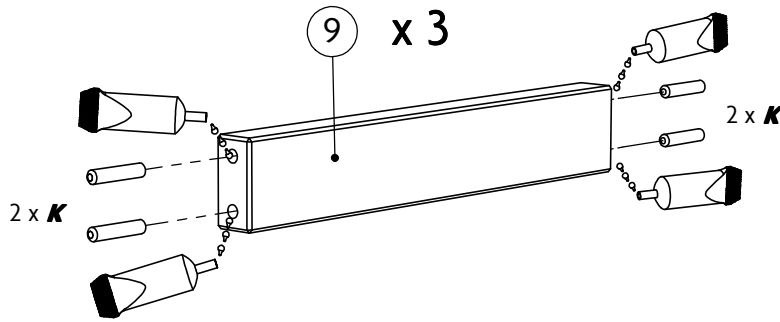
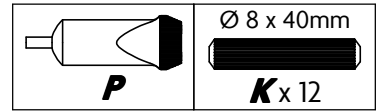

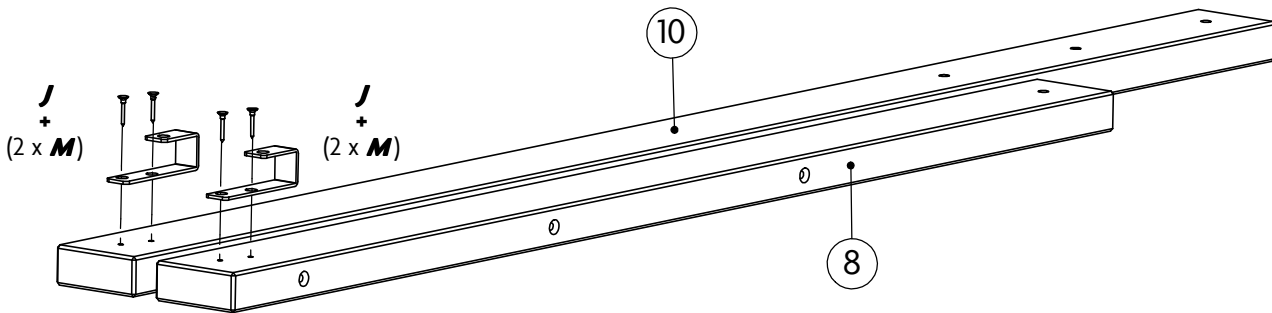
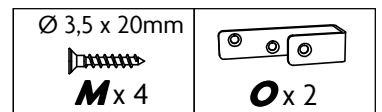

2.

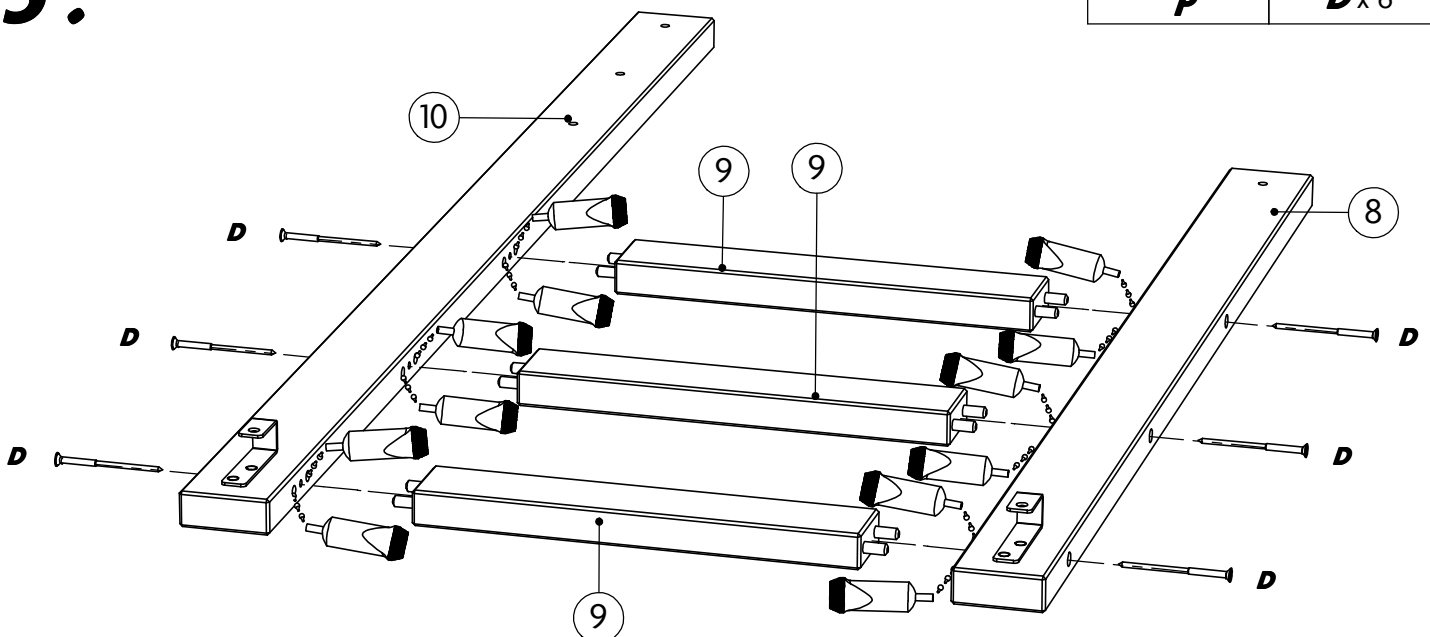
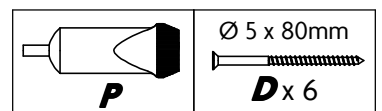

3.



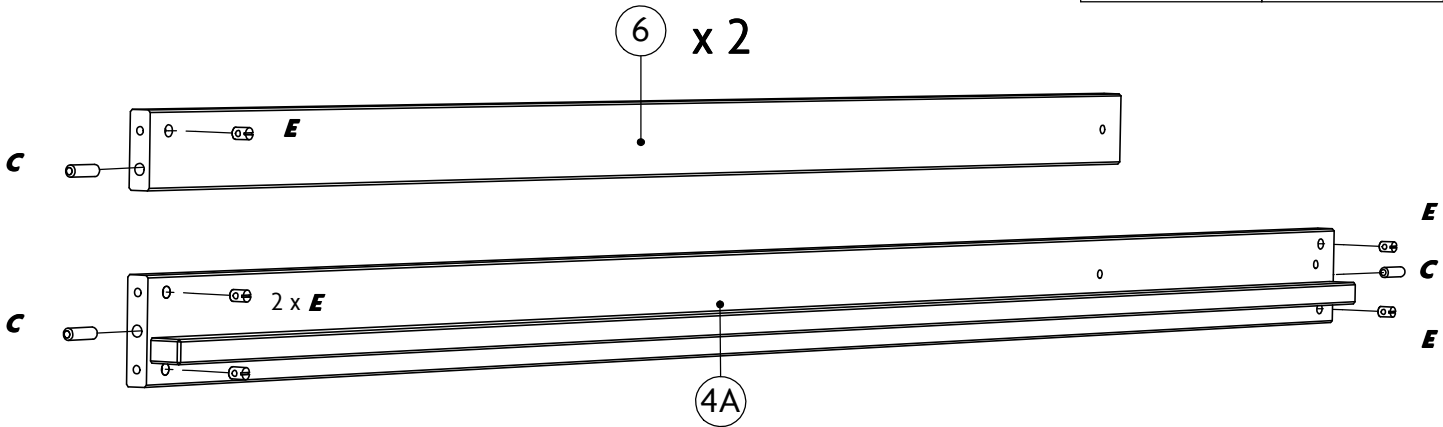

4.

 Ø 10 x 35mm C x 4	 M6 E x 6
--	---



5.

 Ø 10 x 35mm C x 10	 M6 E x 16
---	--

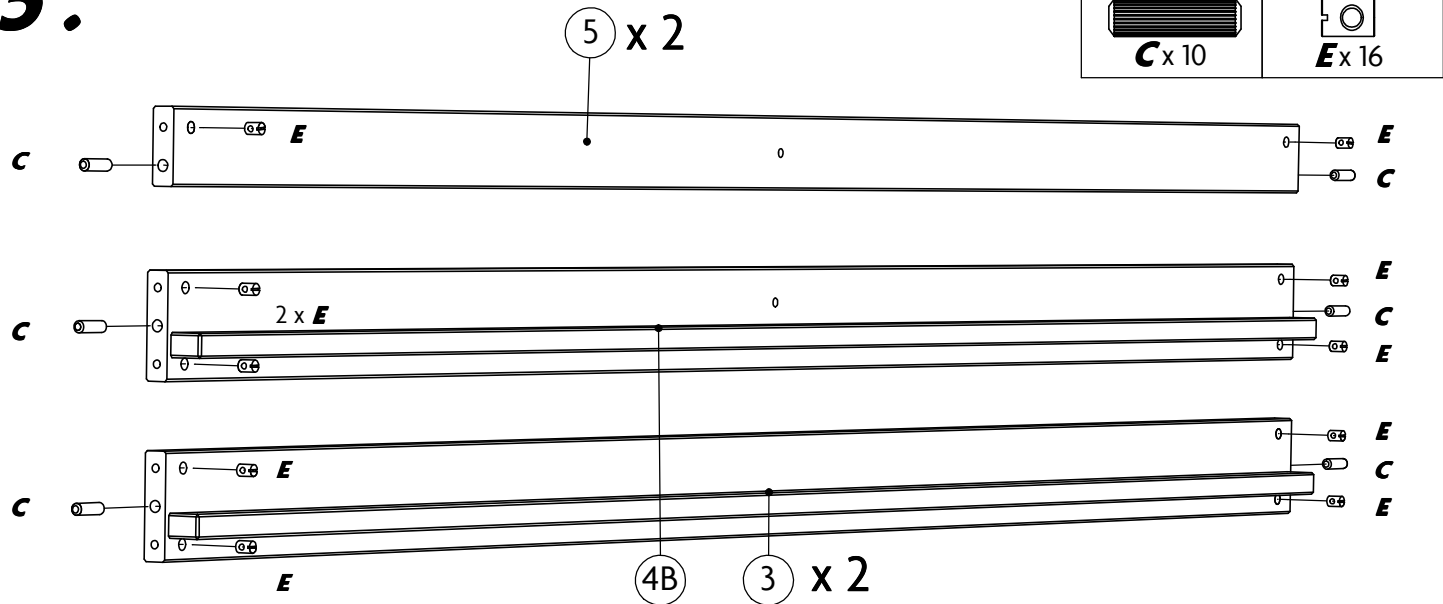

6.

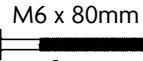
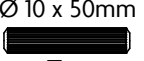
 Q	 M6 x 80mm A x 8	 Ø 10 x 50mm F x 4
---	--	--

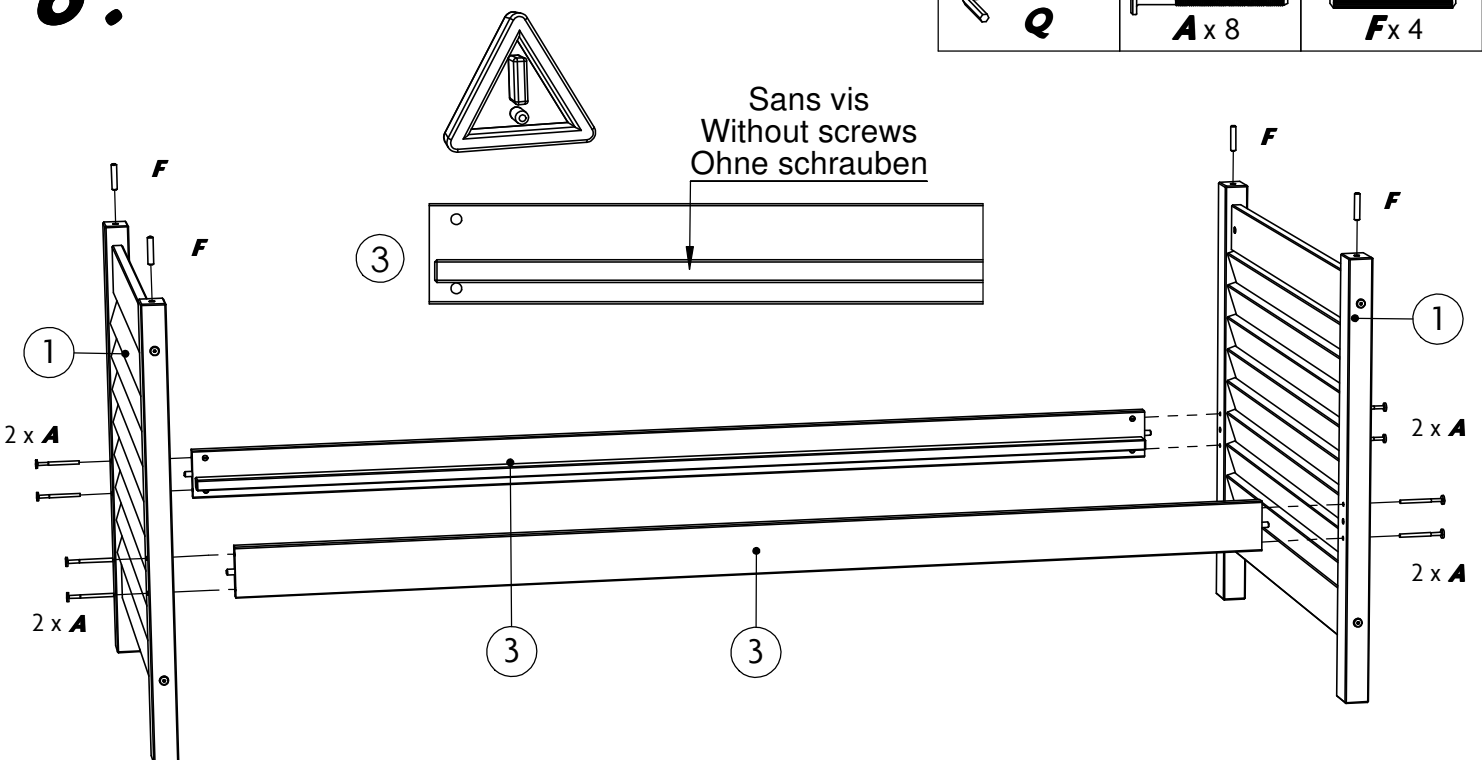

7.

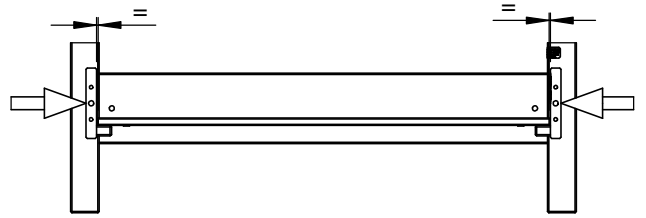
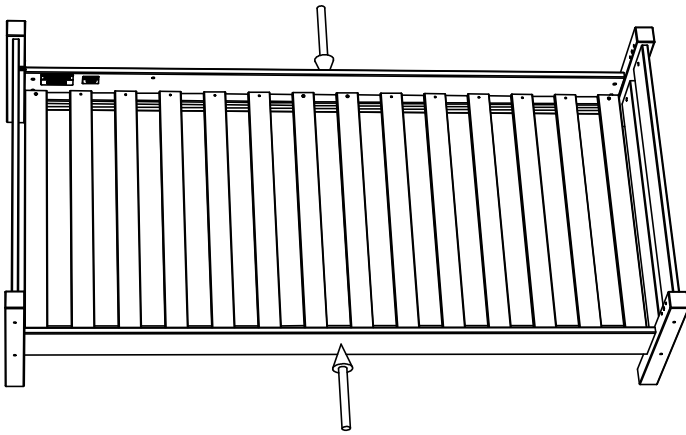
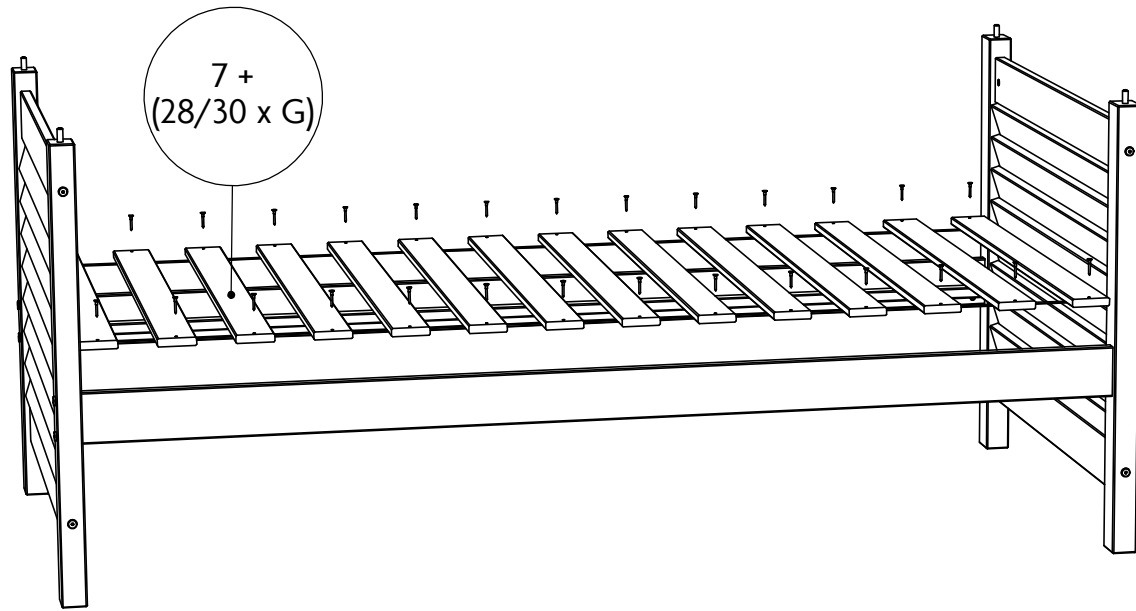

8.

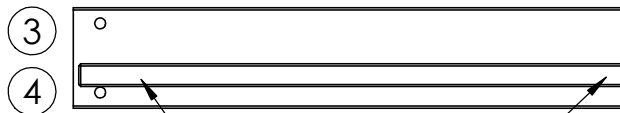
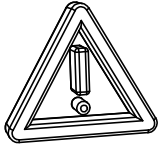

Avec vis
With screws
Mit schrauben

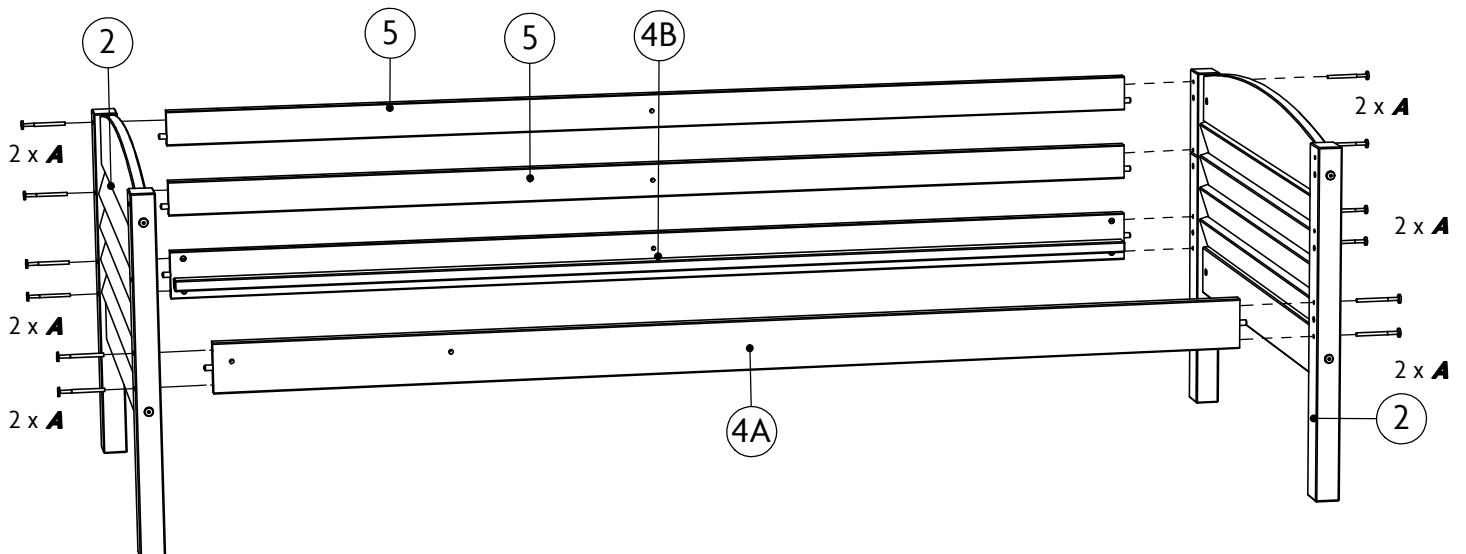
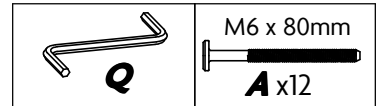

9.

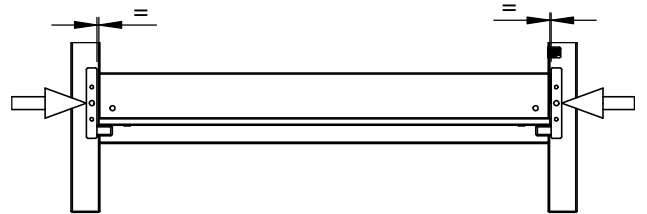
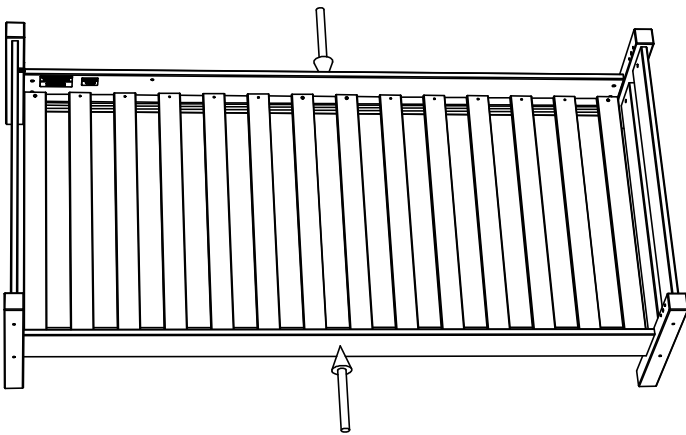
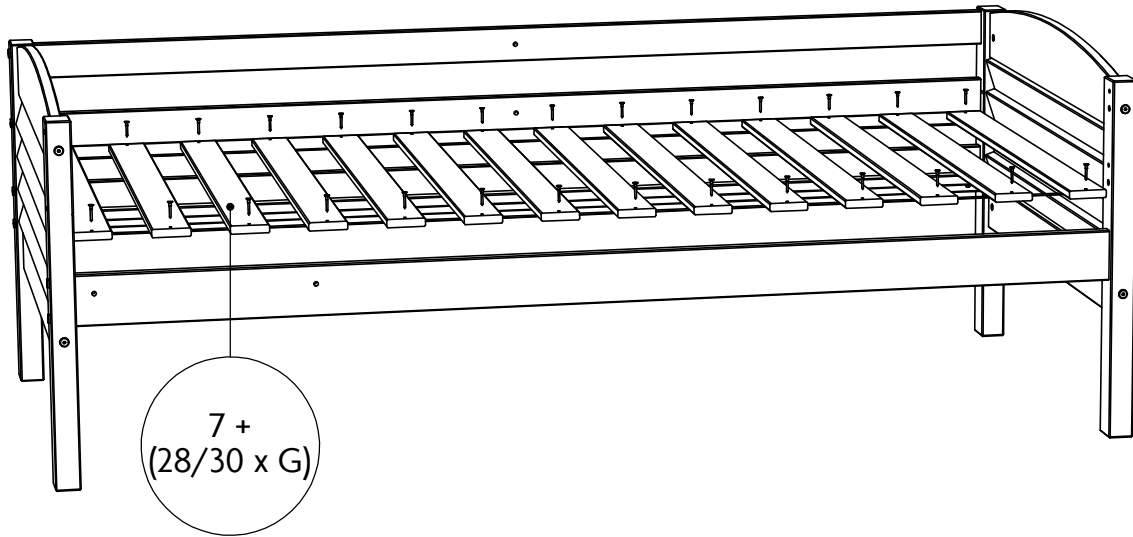

10.

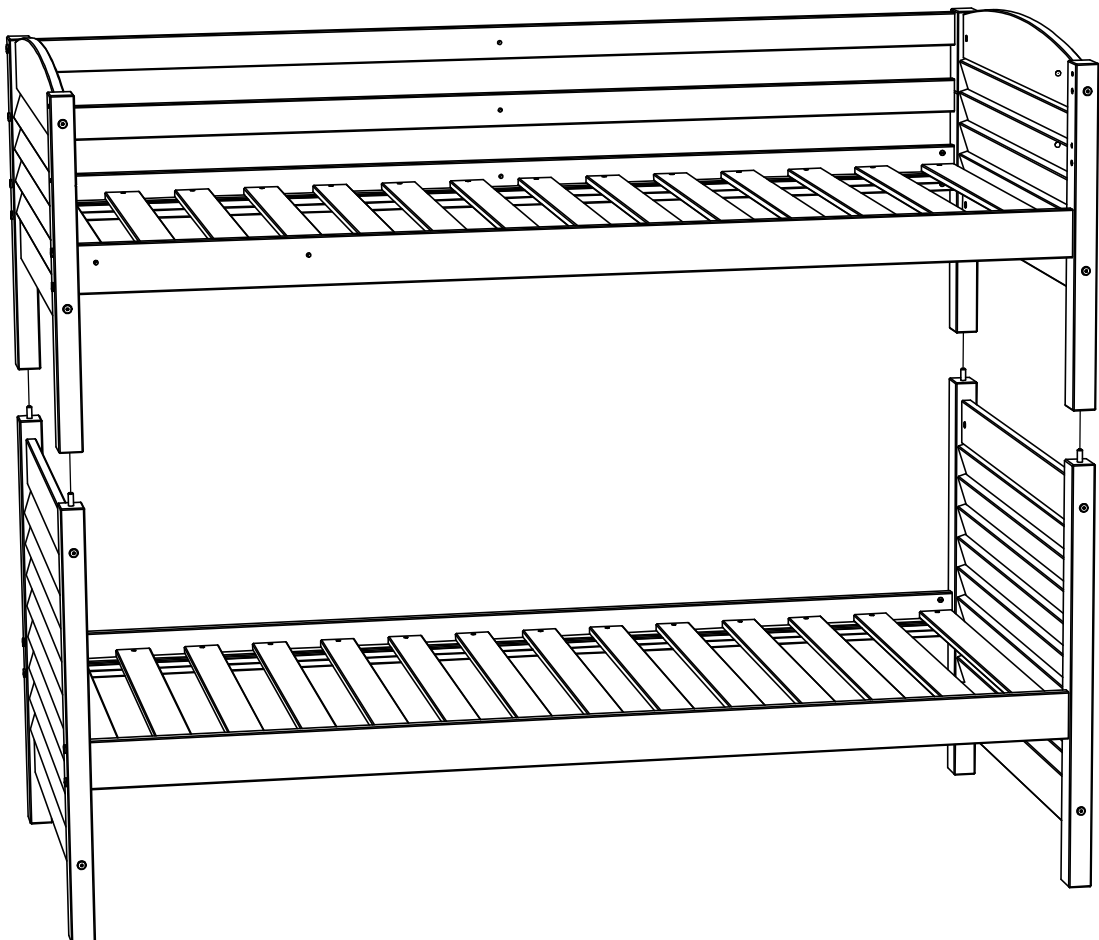

11.

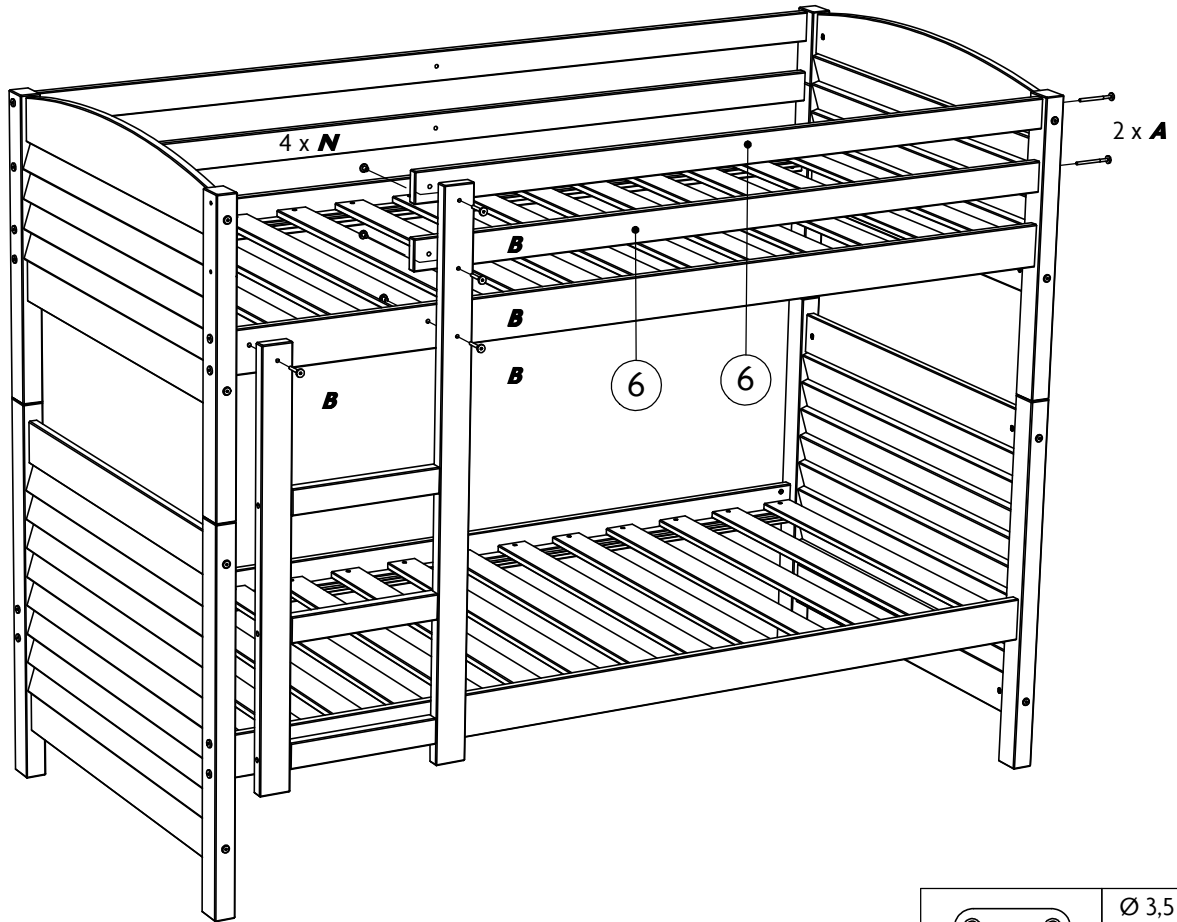
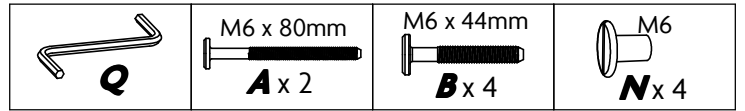

12.

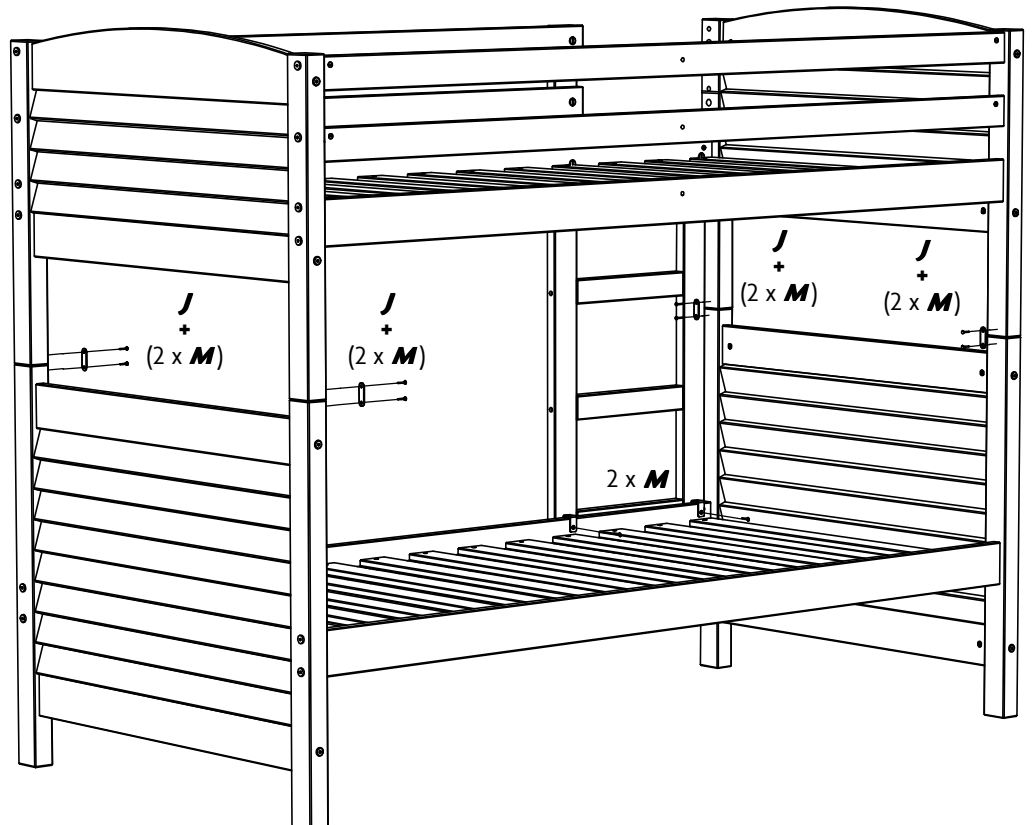
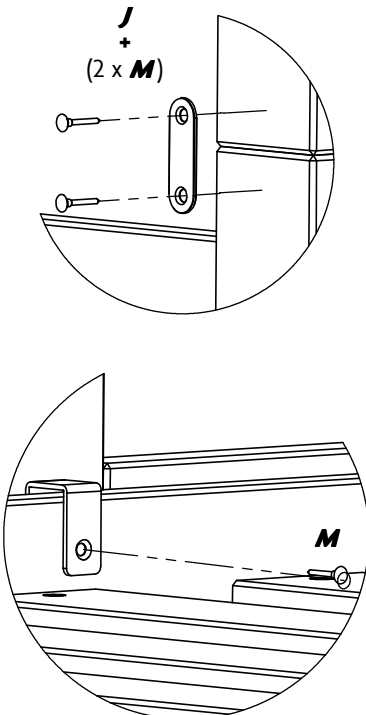
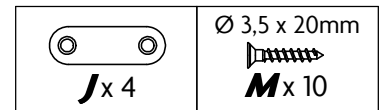

13.

 $\varnothing 10$ H x 2	 $\varnothing 7$ I x 4	 M6 N x 3	 M6 x 35mm R x 3
---	--	--	---

